



# WELL-X-TROL®

Partial Acceptance Bladder Well Tanks: WX Series Non-ASME

125 PSIG Working Pressure

## Construction

Shell	Steel
Bladder Material	Heavy Duty Butyl
Bladder Thickness (models 35-100)	.087 In. Minimum
Bladder Thickness (models 130-600)	.100 In. Minimum
System Connection	Malleable Iron (NPTF)
Finish	Red Oxide Primer
Air Valve	Schrader Valve w/ EPDM Seats
Factory Precharge	25 PSIG (1.7 bar)

## Performance

Maximum Operating Temperature	240°F (115°C)
Maximum Working Pressure	125 PSIG (8.6 bar)
Warranty	1 Year

## Application

- For use in commercial well water and booster pump systems.
- Replaceable bladder design.
- Sight glass and seismic restraint options available.
- Available with S/S system connection.

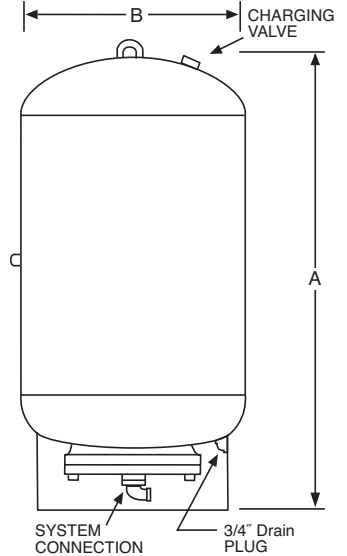
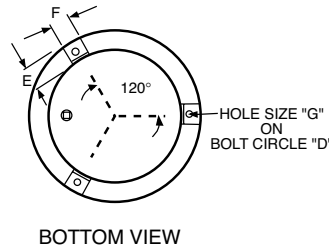

## Non-ASME Models

Model Number	Tank Volume		Max. Accept. Volume		A Tank Height		B Tank Diameter		System Conn. (NPTF)	Shipping Weight	
	Gal	Lit	Gal	Lit	In	mm	In	mm		Lbs	Kg
WX-35L	10	35	10	35	37	940	10	254	1¼	69	32
WX-50L	13	50	11	40	37	940	12	305	1¼	76	35
WX-85L	22	85	11	40	35	889	16	406	1¼	92	42
WX-100L	26	100	11	40	39	991	16	406	1¼	98	45
WX-130L	34	130	27	100	35	889	20	508	1½	136	62
WX-165L	44	165	27	100	40	1016	20	508	1½	146	67
WX-200L	53	200	27	100	41	1041	24	610	1½	198	91
WX-300L	80	300	27	100	56	1423	24	610	1½	236	108
WX-400L	106	400	53	200	69	1753	24	610	2	282	129
WX-500L	132	500	53	200	83	2108	24	610	2	316	144
WX-600L	158	600	53	200	67	1702	30	762	2	450	206

## Optional Seismic Restraints

Tank Diameter	Bolt Circle	Dim.	Dim.	Hole Size
B	D	E	F	G
10	12⅝	2	2	⅜
12	14¾	2	2	⅜
16	14¾	2	2	⅜
20	14¾	2	2	⅜
24	18	2	2	⅜
30	21½	3	3	¾

All dimensions and weights are approximate.

Job Name _____	Notes _____
Engineer _____	_____
Contractor _____	_____
P.O. No. _____	_____
Sales Rep. _____	_____
Model No. _____	_____

