

# EXTROL® Expansion Tanks

## Horizontal AX Series (ASME) 125 PSIG Working Pressure

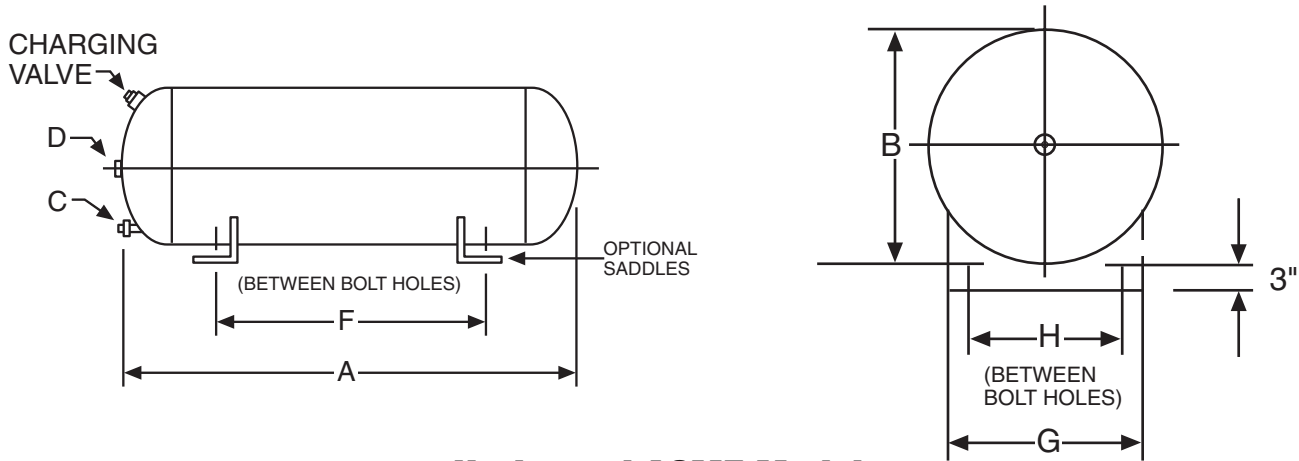

### Horizontal ASME Models

Model No.	Tank Volume		Accept. Volume		A Length		B Diameter		Sys. Conn. ins.		Ship Wt. with Saddles		Saddles for Horizontal Mounting						Ship Wt.	
	Lit.	Gal.	Lit.	Gal.	mm	ins.	mm	ins.	"C"	"D"	kg	lbs.	"F"		"G"		"H"		kg	lbs.
AX-15	30.3	8.0	9.1	2.4	489	19 <sup>1</sup> / <sub>4</sub>	305	12		1/2 <sup>1</sup>	19	41	365	14 <sup>3</sup> / <sub>8</sub>	254	10	203	8	17	37
AX-20	41.3	10.9	9.1	2.4	607	26 <sup>1</sup> / <sub>4</sub>	305	12		1/2 <sup>1</sup>	23	50	537	21 <sup>1</sup> / <sub>8</sub>	254	10	203	8	21	46
AX-40	82.2	21.7	42.8	11.3	737	29	356	16 <sup>1</sup> / <sub>4</sub>		1/2 <sup>1</sup>	44	96	557	22	356	14	305	12	34	74
AX-60	127.2	33.6	42.8	11.3	1073	43	356	16 <sup>1</sup> / <sub>4</sub>		1/2 <sup>1</sup>	53	116	918	36 <sup>3</sup> / <sub>8</sub>	356	14	305	12	44	96
AX-80	168.1	44.4	85.5	22.6	725	28 <sup>9</sup> / <sub>16</sub>	610	24		1 <sup>1</sup>	65	142	429	16 <sup>7</sup> / <sub>8</sub>	508	20	457	18	69	153
AX-100	211.8	55.7	85.5	22.6	840	33	610	24		1 <sup>1</sup>	70	152	546	21 <sup>1</sup> / <sub>2</sub>	508	20	457	18	79	174
AX-120	257.4	68.0	128.7	34.0	1051	41 <sup>3</sup> / <sub>16</sub>	610	24		1 <sup>2</sup>	107	235	749	29 <sup>1</sup> / <sub>2</sub>	508	20	457	18	93	204
AX-144	291.5	77.0	128.7	34.0	1170	46	610	24		1 <sup>2</sup>	112	246	873	34 <sup>3</sup> / <sub>8</sub>	508	20	457	18	99	218
AX-180	340.7	90.0	128.7	34.0	1357	53 <sup>7</sup> / <sub>16</sub>	610	24		1 <sup>2</sup>	113	248	1060	41 <sup>3</sup> / <sub>4</sub>	508	20	457	18	105	232
AX-200	416.4	110.0	128.7	34.0	1624	64	610	24		1 <sup>2</sup>	139	306	1327	52 <sup>1</sup> / <sub>4</sub>	508	20	457	18	122	269
AX-240	500.0	132.0	174.0	46.0	1295	51	762	30		1 <sup>2</sup>	194	428	889	35	610	24	559	22	182	401
AX-260	600.0	159.0	212.0	56.0	1581	62 <sup>1</sup> / <sub>4</sub>	762	30	1 <sup>1</sup> / <sub>4</sub> <sup>2</sup>		218	480	1124	44 <sup>1</sup> / <sub>4</sub>	610	24	559	22	206	455
AX-280	800.0	211.0	318.0	84.0	2032	80	762	30	1 <sup>1</sup> / <sub>4</sub> <sup>2</sup>		299	660	1575	62	610	24	559	22	263	580

<sup>1</sup>System connection is NPTF

<sup>2</sup>System connection is NPTM

### Maximum Operating Conditions

Operating Temperature	240°F (115°C)
Working Pressure	125 PSIG (8.8 bar)

Designed & constructed per ASME Section VIII, Division 1.  
Higher pressures available upon request.

### Specifications

Description	Standard Construction
Shell	Carbon Steel
Diaphragm	Heavy Duty Butyl/EPDM
Coating	Red Oxide Primer

All dimensions and weights are approximate.

Job Name \_\_\_\_\_  
 Location \_\_\_\_\_  
 \_\_\_\_\_  
 \_\_\_\_\_  
 Engineer \_\_\_\_\_

Contractor \_\_\_\_\_  
 Contractor P.O. No. \_\_\_\_\_  
 Sales Representative \_\_\_\_\_  
 Model No. Ordered \_\_\_\_\_  
 ASME CERTIFICATION REQUIRED \_\_\_\_\_ Yes \_\_\_\_\_ No

# EXTROL® Expansion Tanks

## Vertical AX Series (ASME) 125 PSIG Working Pressure

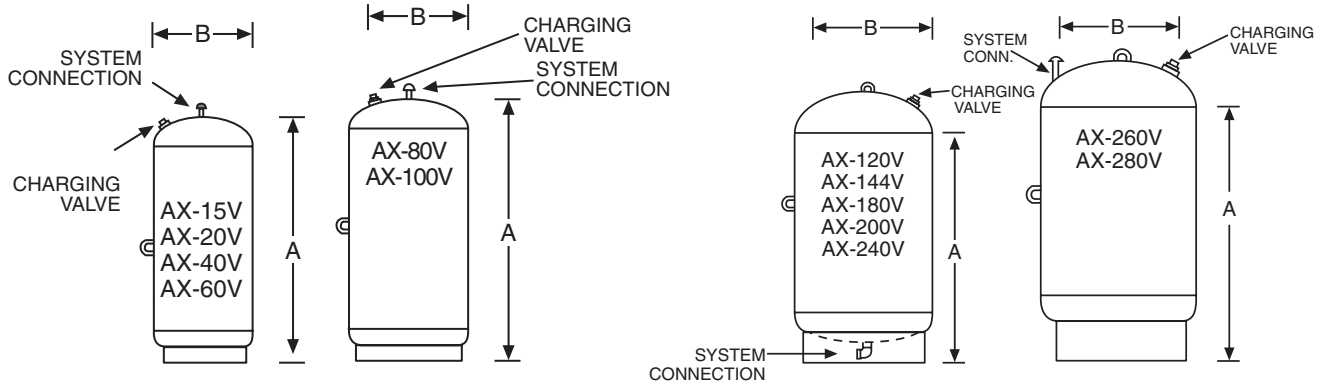

### Vertical ASME Models

Model No.	Tank Volume		Accept Volume		A Height		B Diameter		Sys. Conn: ins.	Ship Weight	
	Lit.	Gal.	Lit.	Gal.	mm	ins.	mm	ins.		kg	lbs.
AX-15V	30.3	8.0	9.1	2.4	495	19½	305	12	½¹	19	41
AX-20V	41.3	10.9	9.1	2.4	673	26½	305	12	½¹	22	49.2
AX-40V	82.2	21.7	42.8	11.3	749	29½	413	16¼	½¹	36	80.4
AX-60V	127.2	33.6	42.8	11.3	1146	45⅞	413	16¼	½¹	47	103
AX-80V	168.1	44.5	85.5	22.6	705	29	610	24	1¹	76	167
AX-100V	211.8	55.7	85.5	22.6	822	33⅛	610	24	1¹	81	179
AX-120V	257.4	68.0	128.7	34.0	1114	47⅞	610	24	1¹	100	221
AX-144V	291.5	77.0	128.7	34.0	1238	52¼	610	24	1¹	106	233
AX-180V	340.7	90.0	128.7	34.0	1426	59⅞	610	24	1¹	116	256
AX-200V	416.4	110.0	128.7	34.0	1591	66⅞	610	24	1¹	126	278
AX-240V	500.0	132.0	174.0	46.0	1357	57⅞	762	30	1¹	198	436
AX-260V	600.0	159.0	212.0	56.0	1537	64¾	762	30	1¼²	212	467
AX-280V	800.0	211.0	318.0	84.0	1989	81¾	762	30	1¼²	274	605

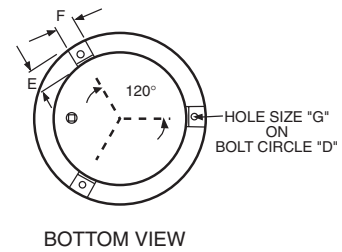

### Optional Seismic Restraints

TANK DIAM. B	BOLT CIRCLE D	DIM. E	DIM. F	HOLE SIZE G
12	12-¾	2	2	9/16
16-¼	14-¾	2	2	9/16
24	18	2	2	9/16
30	27	3	3	¾

¹System connection is NPTF  
²System connection is NPTM

### Maximum Operating Conditions

Operating Temperature	240°F (115°C)
Working Pressure	125 PSIG (8.8 bar)

### Specifications

Description	Standard Construction
Shell	Carbon Steel
Diaphragm	Heavy Duty Butyl/EPDM
System Connection	Forged Steel
Coating	Red Oxide Primer

Designed & constructed per ASME Section VIII, Division 1.

Contractor \_\_\_\_\_

Contractor P.O. No. \_\_\_\_\_

Sales Representative \_\_\_\_\_

Model No. Ordered \_\_\_\_\_

ASME CERTIFICATION REQUIRED \_\_\_\_\_ Yes \_\_\_\_\_ No

Job Name \_\_\_\_\_

Location \_\_\_\_\_

Engineer \_\_\_\_\_

# EXTROL® Expansion Tanks

“L” Series (ASME) 125 PSIG Working Pressure

Model No.	Tank Volume		A Height		B Diameter		C Stand Dia.		Sys. Conn. <sup>1</sup>		Ship Weight		Drain Conn.	
	Lit.	Gal.	mm	ins.	mm	ins.	mm	ins.	mm	ins.	kg	lbs.	mm	ins.
200-L	200	53	956	37 <sup>5</sup> / <sub>8</sub>	610	24	483	19	25	1	86	190	19	3/4
300-L	300	80	1308	51 <sup>1</sup> / <sub>2</sub>	610	24	483	19	25	1	104	230	19	3/4
400-L	400	106	1662	65 <sup>7</sup> / <sub>16</sub>	610	24	483	19	25	1	125	275	19	3/4
500-L	500	132	2006	79	610	24	483	19	25	1	141	311	19	3/4
600-L	600	158	1619	63 <sup>3</sup> / <sub>4</sub>	762	30	610	24	38	1 <sup>1</sup> / <sub>2</sub>	199	439	25	1
800-L	800	211	2076	81 <sup>3</sup> / <sub>4</sub>	762	30	610	24	38	1 <sup>1</sup> / <sub>2</sub>	246	543	25	1
1000-L	1000	264	1867	73 <sup>1</sup> / <sub>2</sub>	914	36	762	30	38	1 <sup>1</sup> / <sub>2</sub>	276	609	32	1 <sup>1</sup> / <sub>4</sub>
1200-L	1200	317	2181	85 <sup>7</sup> / <sub>8</sub>	914	36	762	30	38	1 <sup>1</sup> / <sub>2</sub>	318	700	32	1 <sup>1</sup> / <sub>4</sub>
1400-L	1400	370	2496	98 <sup>1</sup> / <sub>4</sub>	914	36	762	30	38	1 <sup>1</sup> / <sub>2</sub>	355	783	32	1 <sup>1</sup> / <sub>4</sub>
1600-L	1600	422	1756	69 <sup>1</sup> / <sub>8</sub>	1219	48	1067	42	38	1 <sup>1</sup> / <sub>2</sub>	502	1106	38	1 <sup>1</sup> / <sub>2</sub>
2000-L	2000	528	2145	84	1219	48	1067	42	38	1 <sup>1</sup> / <sub>2</sub>	582	1284	38	1 <sup>1</sup> / <sub>2</sub>
2500-L	2500	660	2562	100 <sup>7</sup> / <sub>8</sub>	1219	48	1067	42	50	2	700	1544	38	1 <sup>1</sup> / <sub>2</sub>
3000-L	3000	792	3000	118 <sup>1</sup> / <sub>8</sub>	1219	48	1067	42	50	2	780	1719	38	1 <sup>1</sup> / <sub>2</sub>
3500-L	3500	925	2820	111	1372	54	1067	42	50	2	992	2187	38	1 <sup>1</sup> / <sub>2</sub>
4000-L	4000	1057	3175	125	1372	54	1067	42	50	2	1067	2352	38	1 <sup>1</sup> / <sub>2</sub>
5000-L	5000	1321	3251	128	1524	60	1067	42	50	2	1111	2450	38	1 <sup>1</sup> / <sub>2</sub>
7500-L	7500	1980	3226	127	1829	72	1372	54	76	3	1818	4000	38	1 <sup>1</sup> / <sub>2</sub>
7500-L <sub>CAN</sub>	7500	1980	3658	144	1829	72	1372	54	76	3	1818	4000	38	1 <sup>1</sup> / <sub>2</sub>
10000-L	10000	2640	4039	159	1829	72	1372	54	76	3	2227	4900	38	1 <sup>1</sup> / <sub>2</sub>
15000-L	15000	3963	5918	233	1829	72	1372	54	76	3	2727	6000	38	1 <sup>1</sup> / <sub>2</sub>

<sup>1</sup>System connection is NPTF

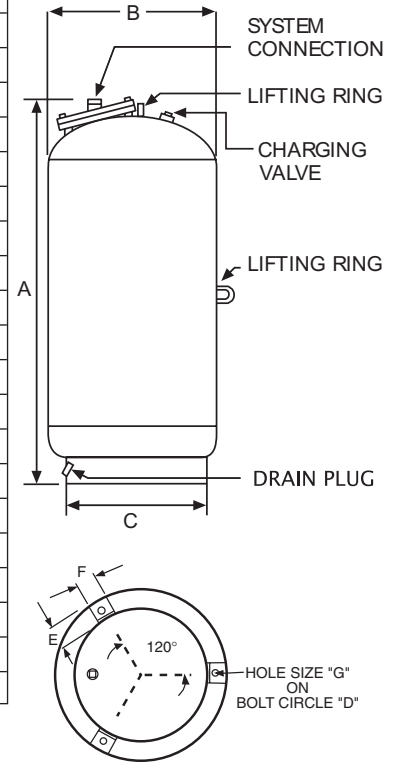

BOTTOM VIEW

## Maximum Operating Conditions

Operating Temperature	240°F (115°C)
Working Pressure	125 PSIG (8.8 bar)

\*Available in 150, 175, 250, or 300 PSIG

## Specifications

Description	Standard Construction
Shell	Steel
Bladder	Heavy Duty Butyl
Bladder Thickness	.100 Ins. Minimum
System Connection	Forged Steel
Factory Precharge	12 PSIG (.84 bar)
Finish	Red Oxide Primer

Designed & constructed per ASME Section VIII, Division 1.

## Optional Seismic Restraints

TANK Diam B	BOLT CIRCLE D	DIM. E	DIM. F	HOLE SIZE G
24	21	2	2	9/16
30	27	3	3	1 <sup>1</sup> / <sub>16</sub>
36	34	4	4	7/8
48	46	4	4	7/8
54	46	4	4	7/8
60	46	4	4	7/8
72	58	4	4	1

All dimensions and weights are approximate.

Job Name \_\_\_\_\_

Location \_\_\_\_\_

\_\_\_\_\_

Engineer \_\_\_\_\_

Contractor \_\_\_\_\_

Contractor P.O. No. \_\_\_\_\_

Sales Representative \_\_\_\_\_

Model No. Ordered \_\_\_\_\_

ASME CERTIFICATION REQUIRED \_\_\_\_\_ Yes \_\_\_\_\_ No

# EXTROL® Expansion Tanks

“L” Series (ASME) 150 PSIG Working Pressure

## 150 PSIG WP ASME Models

Model No.	Tank Volume		A Height		B Diameter		C Stand Dia.		Sys. Conn. <sup>1</sup>		Ship Weight		Drain Conn.	
	Lit.	Gal.	mm	ins.	mm	ins.	mm	ins.	mm	ins.	kg	lbs.	mm	ins.
200-L	200	53	956	37 <sup>5</sup> / <sub>8</sub>	610	24	483	19	25	1	93	205	19	3/4
300-L	300	80	1308	51 <sup>1</sup> / <sub>2</sub>	610	24	483	19	25	1	133	292	19	3/4
400-L	400	106	1662	65 <sup>7</sup> / <sub>16</sub>	610	24	483	19	25	1	156	343	19	3/4
500-L	500	132	2006	79	610	24	483	19	25	1	169	372	19	3/4
600-L	600	158	1619	63 <sup>3</sup> / <sub>4</sub>	762	30	610	24	38	1 <sup>1</sup> / <sub>2</sub>	231	510	25	1
800-L	800	211	2076	81 <sup>3</sup> / <sub>4</sub>	762	30	610	24	38	1 <sup>1</sup> / <sub>2</sub>	257	565	25	1
1000-L	1000	264	1867	73 <sup>1</sup> / <sub>2</sub>	914	36	762	30	38	1 <sup>1</sup> / <sub>2</sub>	340	750	32	1 <sup>1</sup> / <sub>4</sub>
1200-L	1200	317	2181	85 <sup>7</sup> / <sub>8</sub>	914	36	762	30	38	1 <sup>1</sup> / <sub>2</sub>	390	860	32	1 <sup>1</sup> / <sub>4</sub>
1400-L	1400	370	2496	98 <sup>1</sup> / <sub>4</sub>	914	36	762	30	38	1 <sup>1</sup> / <sub>2</sub>	440	970	32	1 <sup>1</sup> / <sub>4</sub>
1600-L	1600	422	1756	69 <sup>1</sup> / <sub>8</sub>	1219	48	1067	42	38	1 <sup>1</sup> / <sub>2</sub>	647	1425	38	1 <sup>1</sup> / <sub>2</sub>
2000-L	2000	528	2145	84	1219	48	1067	42	38	1 <sup>1</sup> / <sub>2</sub>	760	1675	38	1 <sup>1</sup> / <sub>2</sub>
2500-L	2500	660	2562	100 <sup>7</sup> / <sub>8</sub>	1219	48	1067	42	50	2	883	1945	38	1 <sup>1</sup> / <sub>2</sub>
3000-L	3000	792	3000	118 <sup>1</sup> / <sub>8</sub>	1219	48	1067	42	50	2	1010	2225	38	1 <sup>1</sup> / <sub>2</sub>
3500-L	3500	925	2820	111	1372	54	1067	42	50	2	1078	2375	38	1 <sup>1</sup> / <sub>2</sub>
4000-L	4000	1057	3175	125	1372	54	1067	42	50	2	1198	2640	38	1 <sup>1</sup> / <sub>2</sub>
5000-L	5000	1321	3251	128	1524	60	1067	42	50	2	1700	3740	38	1 <sup>1</sup> / <sub>2</sub>
7500-L	7500	1980	3226	127	1829	72	1372	54	76	3	1950	4300	38	1 <sup>1</sup> / <sub>2</sub>
7500-L <sub>CAN</sub>	7500	1980	3658	144	1829	72	1372	54	76	3	1950	4300	38	1 <sup>1</sup> / <sub>2</sub>
10000-L	10000	2640	4039	159	1829	72	1372	54	76	3	2404	5300	38	1 <sup>1</sup> / <sub>2</sub>
15000-L	15000	3963	5918	233	1829	72	1372	54	76	3	3447	7600	38	1 <sup>1</sup> / <sub>2</sub>

<sup>1</sup>System connection is NPTF

### Maximum Operating Conditions

Operating Temperature	240°F (115°C)
Working Pressure	150 PSIG (10.5 bar)

\*Available in 125, 175, 250 or 300 PSIG.

### Specifications

Description	Standard Construction
Shell	Steel
Bladder	Heavy Duty Butyl
Bladder Thickness	.100 Ins. Minimum
System Connection	Forged Steel
Factory Precharge	12 PSIG (.84 bar)
Finish	Red Oxide Primer

Designed & constructed per ASME Section VIII, Division 1.

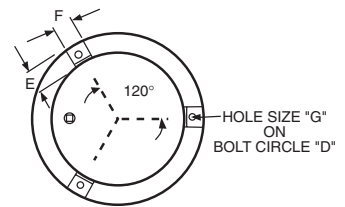
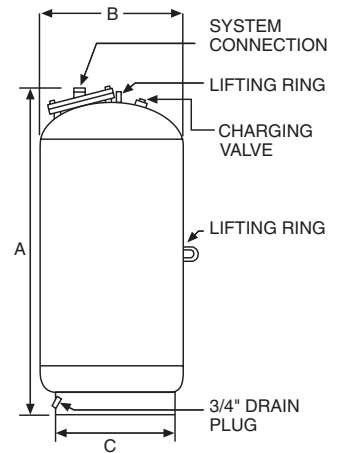

BOTTOM VIEW

### Optional Seismic Restraints

TANK Diam B	BOLT CIRCLE D	DIM. E	DIM. F	HOLE SIZE G
24	21	2	2	9/16
30	27	3	3	1 <sup>1</sup> / <sub>16</sub>
36	34	4	4	7/8
48	46	4	4	7/8
54	46	4	4	7/8

All dimensions and weights are approximate.

Job Name \_\_\_\_\_

Location \_\_\_\_\_

\_\_\_\_\_

Engineer \_\_\_\_\_

Contractor \_\_\_\_\_

Contractor P.O. No. \_\_\_\_\_

Sales Representative \_\_\_\_\_

Model No. Ordered \_\_\_\_\_

ASME CERTIFICATION REQUIRED \_\_\_\_\_ Yes \_\_\_\_\_ No

# EXTROL® Expansion Tanks

“L” Series (ASME) 175 PSIG Working Pressure

## 175 PSIG WP ASME Models

Model No.	Tank Volume		A Height		B Diameter		C Stand Dia.		Sys. Conn. <sup>1</sup>	Shipping Weight	
	Lit.	Gal.	mm	ins.	mm	ins.	mm	ins.		kg	lbs.
200-L	200	53	940	37	610	24	483	19	1	114	250
300-L	300	80	1302	51¼	610	24	483	19	1	146	320
400-L	400	106	1654	65½	610	24	483	19	1	170	375
500-L	500	132	2010	79½	610	24	483	19	1	198	435
600-L	600	158	1651	65	762	30	610	24	1½	270	595
800-L	800	211	2108	83	762	30	610	24	1½	282	620
1000-L	1000	264	1867	73½	914	36	762	30	1½	340	750
1200-L	1200	317	2181	85½	914	36	762	30	1½	390	860
1400-L	1400	370	2496	98¼	914	36	762	30	1½	440	970
1600-L	1600	422	1768	69½	1219	48	1067	42	1½	647	1425
2000-L	2000	528	2121	83½	1219	48	1067	42	1½	760	1675
2500-L	2500	660	2562	100½	1219	48	1067	42	2	883	1945
3000-L	3000	792	3000	118½	1219	48	1067	42	2	1010	2225
3500-L	3500	925	2820	111	1372	54	1067	42	2	1078	2375
4000-L	4000	1057	3163	124½	1372	54	1067	42	2	1198	2640
5000-L	5000	1321	3251	128	1524	60	1067	42	2	1863	4100
7500-L	7500	1980	3658	144	1829	72	1372	54	3	2045	4500
7500-L <sub>CAN</sub>	7500	1980	3226	127	1829	72	1372	54	3	2045	4500
10000-L	10000	2640	4039	159	1829	72	1372	54	3	2500	5500
15000-L	15000	3963	5918	233	1829	72	1372	54	3	3590	7900

<sup>1</sup>System connection is NPT

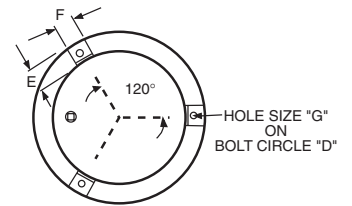
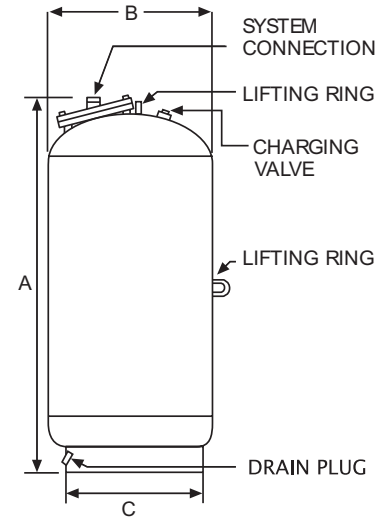

BOTTOM VIEW

## Maximum Operating Conditions

Operating Temperature	240°F (115°C)
Working Pressure	175 PSIG (12.3 bar)

## Specifications

Description	Standard Construction
Shell	Steel
Bladder	Heavy Duty Butyl
Bladder Thickness	.100 Ins. Minimum
System Connection	Forged Steel
Factory Precharge	12 PSIG (.84bar)
Finish	Red Oxide Primer

Designed & constructed per ASME Section VIII, Division 1.

## Optional Seismic Restraints

TANK Diam B	BOLT CIRCLE D	DIM. E	DIM. F	HOLE SIZE G
24	21	2	2	9/16
30	28	4	4	7/8
36	34	4	4	7/8
48	46	4	4	7/8
54	46	4	4	7/8
60	46	4	4	7/8
72	58	4	4	1

All dimensions and weights are approximate.

Job Name \_\_\_\_\_

Location \_\_\_\_\_

\_\_\_\_\_

Engineer \_\_\_\_\_

Contractor \_\_\_\_\_

Contractor P.O. No. \_\_\_\_\_

Sales Representative \_\_\_\_\_

Model No. Ordered \_\_\_\_\_

ASME CERTIFICATION REQUIRED \_\_\_\_\_ Yes \_\_\_\_\_ No

# EXTROL® Expansion Tanks

“L” Series (ASME) 250 PSIG Working Pressure

## 250 PSIG WP ASME Models

Model No.	Tank Volume		A Height		B Diameter		C Stand Dia.		Sys. Conn. <sup>1</sup>	Shipping Weight	
	Lit.	Gal.	mm	ins.	mm	ins.	mm	ins.		kg	lbs.
200-L	200	53	940	37	610	24	483	19	1	132	290
300-L	300	80	1302	51¼	610	24	483	19	1	175	385
400-L	400	106	1654	65⅞	610	24	483	19	1	211	465
500-L	500	132	2010	79⅞	610	24	483	19	1	248	545
600-L	600	158	1651	65	762	30	610	24	1½	327	720
800-L	800	211	2108	83	762	30	610	24	1½	411	905
1000-L	1000	264	1867	73½	914	36	762	30	1½	461	1015
1200-L	1200	317	2181	85⅞	914	36	762	30	1½	533	1175
1400-L	1400	370	2496	98¼	914	36	762	30	1½	606	1335
1600-L	1600	422	1768	69⅝	1219	48	1067	42	1½	869	1916
2000-L	2000	528	2121	83½	1219	48	1067	42	1½	1005	2215
2500-L	2500	660	2562	100⅞	1219	48	1067	42	2	1173	2585
3000-L	3000	792	3000	118½	1219	48	1067	42	2	1338	2950
3500-L	3500	925	2820	111	1372	54	1067	42	2	1661	3660
4000-L	4000	1057	3163	124½	1372	54	1067	42	2	1851	4080
5000-L	5000	1321	3251	128	1524	60	1067	42	2	1909	4200
7500-L	7500	1980	3226	127	1829	72	1372	54	3	2522	5550
7500-LCAN	7500	1980	3658	144	1829	72	1372	54	3	2522	5550
10000-L	10000	2640	4039	159	1829	72	1372	54	3	3090	6800
15000-L	15000	3963	5918	233	1829	72	1372	54	3	4454	9800

<sup>1</sup>System connection is NPT

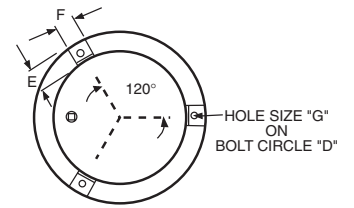
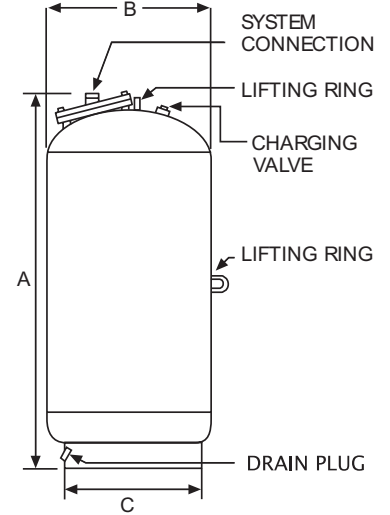

BOTTOM VIEW

## Maximum Operating Conditions

Operating Temperature	240°F (115°C)
Working Pressure	250 PSIG (17.6 bar)

## Specifications

Description	Standard Construction
Shell	Steel
Bladder	Heavy Duty Butyl
Bladder Thickness	.100 Ins. Minimum
System Connection	Forged Steel
Factory Precharge	12 PSIG (.84bar)
Finish	Red Oxide Primer

Designed & constructed per ASME Section VIII, Division 1.

## Optional Seismic Restraints

TANK Diam B	BOLT CIRCLE D	DIM. E	DIM. F	HOLE SIZE G
24	21	2	2	9/16
30	28	4	4	7/8
36	34	4	4	7/8
48	46	4	4	7/8
54	46	4	4	7/8
60	46	4	4	7/8
72	58	4	4	1

All dimensions and weights are approximate.

Job Name \_\_\_\_\_

Location \_\_\_\_\_

Engineer \_\_\_\_\_

Contractor \_\_\_\_\_

Contractor P.O. No. \_\_\_\_\_

Sales Representative \_\_\_\_\_

Model No. Ordered \_\_\_\_\_

ASME CERTIFICATION REQUIRED \_\_\_\_\_ Yes \_\_\_\_\_ No

# EXTROL® Expansion Tanks

“LBC” Series Bottom Connection Bladder Series (ASME) 125 PSIG Working Pressure

## 125 PSIG WP ASME Models

Model No.	Tank Volume		Accept Volume		A Height		B Diameter		Sys. Conn. <sup>1</sup>		Ship Weight	
	Lit.	Gal.	Lit.	Gal.	mm	ins.	mm	ins.	mm	ins.	kg	lbs.
35LBC	35	10	35	10	948	37 <sup>1</sup> / <sub>16</sub>	254	10	25	1	30	67
50LBC	50	13	40	11	941	37 <sup>1</sup> / <sub>16</sub>	305	12	25	1	34	76
85LBC	85	22	40	11	872	34 <sup>5</sup> / <sub>16</sub>	406	16	25	1	42	92
100LBC	100	26	40	11	991	39	406	16	25	1	45	99
130LBC	130	34	100	27	881	34 <sup>1</sup> / <sub>16</sub>	508	20	25	1	61	135
165LBC	165	44	100	27	1008	39 <sup>1</sup> / <sub>16</sub>	508	20	25	1	68	149
200LBC	200	53	100	27	1039	40 <sup>7</sup> / <sub>8</sub>	610	24	25	1	88	195
300LBC	300	80	100	27	1423	56	610	24	25	1	106	233
400LBC	400	106	200	53	1743	68 <sup>5</sup> / <sub>8</sub>	610	24	25	1	124	274
500LBC	500	132	200	53	2096	82 <sup>1</sup> / <sub>2</sub>	610	24	25	1	141	310
600LBC	600	158	200	53	1702	67	762	30	25	1	199	438

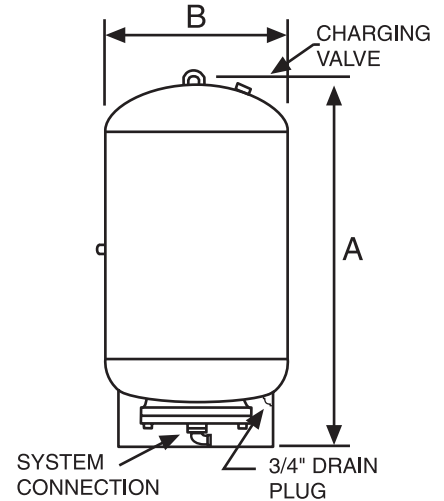

<sup>1</sup>System connection is NPTF

## Maximum Operating Conditions

Operating Temperature	240°F (115°C)
Working Pressure	125 PSIG (8.8 bar)

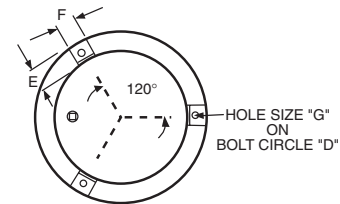

BOTTOM VIEW

## Specifications

Description	Standard Construction
Shell	Carbon Steel
Bladder Material	Heavy Duty Butyl
Bladder Thickness (models 35-100)	.087 Ins. Minimum
Bladder Thickness (models 130-600)	.100 Ins. Minimum
System Connection	Malleable Iron
Coating	Red Oxide Primer
Factory Precharge	12 PSIG (.84 bar)

Designed & constructed per ASME Section VIII, Division 1.

## Optional Seismic Restraints

TANK Diam B	BOLT CIRCLE D	DIM. E	DIM. F	HOLE SIZE G
10	12 <sup>5</sup> / <sub>8</sub>	2	2	9/16
12	14 <sup>3</sup> / <sub>4</sub>	2	2	9/16
16	16 <sup>3</sup> / <sub>4</sub>	2	2	9/16
20	16 <sup>3</sup> / <sub>4</sub>	2	2	9/16
24	18	2	2	9/16
30	24	4	4	7/8

All dimensions and weights are approximate.

Job Name \_\_\_\_\_

Location \_\_\_\_\_

Engineer \_\_\_\_\_

Contractor \_\_\_\_\_

Contractor P.O. No. \_\_\_\_\_

Sales Representative \_\_\_\_\_

Model No. Ordered \_\_\_\_\_

ASME CERTIFICATION REQUIRED \_\_\_\_\_ Yes \_\_\_\_\_ No

# EXTROL® Expansion Tanks

“LBC” Series Bottom Connection Bladder Series (ASME) 150 PSIG Working Pressure

## 150 PSIG WP ASME Models

Model No.	Tank Volume		Accept Volume		A Height		B Diameter		Sys. Conn. <sup>1</sup>		Ship Weight	
	Lit.	Gal.	Lit.	Gal.	mm	ins.	mm	ins.	mm	ins.	kg	lbs.
35LBC	35	10	35	10	985	38 <sup>13</sup> / <sub>16</sub>	254	10	25	1	29	65
50LBC	50	13	40	11	985	38 <sup>13</sup> / <sub>16</sub>	305	12	25	1	33	72
85LBC	85	22	40	11	951	37 <sup>7</sup> / <sub>16</sub>	406	16	25	1	40	88
100LBC	100	26	40	11	1070	42 <sup>1</sup> / <sub>8</sub>	406	16	25	1	43	94
130LBC	130	34	100	27	962	37 <sup>7</sup> / <sub>8</sub>	508	20	25	1	59	130
165LBC	165	44	100	27	1089	42 <sup>7</sup> / <sub>8</sub>	508	20	25	1	64	140
200LBC	200	53	100	27	1039	40 <sup>7</sup> / <sub>8</sub>	610	24	25	1	93	205
300LBC	300	80	100	27	1423	56	610	24	25	1	115	254
400LBC	400	106	200	53	1743	68 <sup>5</sup> / <sub>8</sub>	610	24	25	1	140	308
500LBC	500	132	200	53	2096	82 <sup>1</sup> / <sub>2</sub>	610	24	25	1	160	352
600LBC	600	158	200	53	1702	67	762	30	25	1	201	442

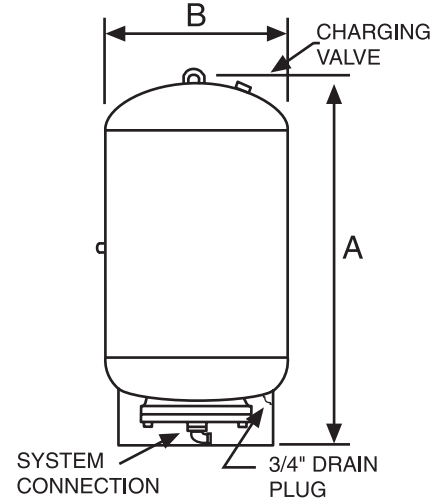

<sup>1</sup>System connection is NPTF

## Maximum Operating Conditions

Operating Temperature	240°F (115°C)
Working Pressure	150 PSIG (10.5 bar)

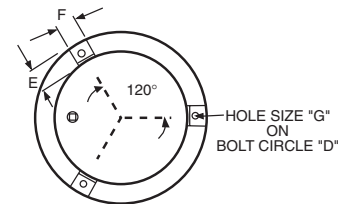

BOTTOM VIEW

## Specifications

Description	Standard Construction
Shell	Carbon Steel
Bladder Material	Heavy Duty Butyl
Bladder Thickness (models 35-100)	.087 Ins. Minimum
Bladder Thickness (models 130-600)	.100 Ins. Minimum
System Connection	Malleable Iron
Coating	Red Oxide Primer
Factory Precharge	12 PSIG (.84 bar)

Designed & constructed per ASME Section VIII, Division 1.

## Optional Seismic Restraints

TANK Diam B	BOLT CIRCLE D	DIM. E	DIM. F	HOLE SIZE G
10	12 <sup>5</sup> / <sub>8</sub>	2	2	9/16
12	14 <sup>3</sup> / <sub>4</sub>	2	2	9/16
16	16 <sup>3</sup> / <sub>4</sub>	2	2	9/16
20	16 <sup>3</sup> / <sub>4</sub>	2	2	9/16
24	18	2	2	9/16
30	22 <sup>3</sup> / <sub>4</sub>	3	3	3/4

All dimensions and weights are approximate.

Job Name \_\_\_\_\_

Location \_\_\_\_\_

Engineer \_\_\_\_\_

Contractor \_\_\_\_\_

Contractor P.O. No. \_\_\_\_\_

Sales Representative \_\_\_\_\_

Model No. Ordered \_\_\_\_\_

ASME CERTIFICATION REQUIRED \_\_\_\_\_ Yes \_\_\_\_\_ No