



SURGE-TROL®

Fire Protection Expansion Tanks: SPT Series ASME/UL

275 PSIG Working Pressure

Construction

Shell	ASME Approved Steel
Bladder Material	Heavy Duty Butyl/NSF/ANSI 61
Bladder Thickness	.100 Minimum
System Connection	Steel - ANSI Flange
Finish	Red Oxide Primer
Air Valve	Schrader Valve w/EPDM Seats
Factory Precharge	25 PSIG (1.7 bar)

Performance

Maximum Operating Temperature	240°F (115°C)
Maximum Working Pressure	275 PSIG (19 bar)
Warranty	1 Year

Application

- For use in absorption of pump start-up and shut-down surges in fire protection sprinkler systems.
- Replaceable, heavy-duty bladder design.
- Compatible with glycerin, propylene glycol and ethylene systems.
- Seismic restraints come standard; sight glass is optional.
- Designed and constructed per ASME Code Section VIII, Division 1.

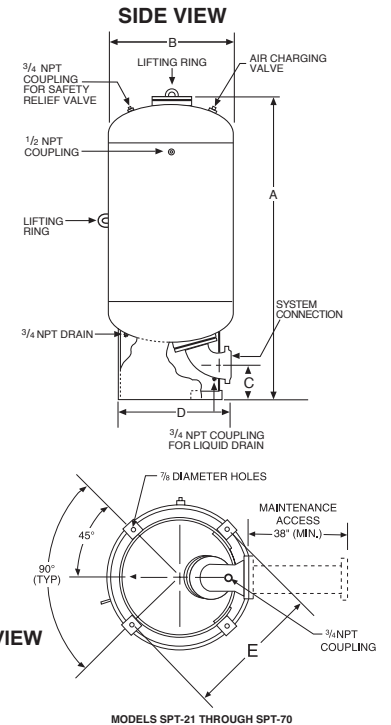

ASME Models

Model Number	Tank Volume		A Tank Height		B Tank Diameter		Sys. Conn.		C Conn. Centerline		D Stand Diameter		Shipping Weight	
	Gal	Lit	In	mm	In	mm	In	mm	In	mm	In	mm	Lbs	Kg
SPT-1*	10	38	31	787	16	406	2	51	5½	140	16	406	200	91
SPT-3*	25	95	49	1245	16	406	3	76	5½	140	16	406	273	124
SPT-7	53	200	49	1245	24	610	4	102	7¾	197	19	483	390	177
SPT-11	80	300	63	1600	24	610	4	102	7¾	197	19	483	505	229
SPT-14	106	400	77	1956	24	610	4	102	7¾	197	19	483	618	280
SPT-18	132	500	91	2311	24	610	4	102	7¾	197	19	483	731	332
SPT-21	158	600	75	1905	30	762	4	102	8%	213	24	610	950	431
SPT-28	211	800	93	2362	30	762	4	102	8%	213	24	610	1125	510
SPT-35	264	1000	85	2159	36	914	6	152	10¼	213	30	762	1520	689
SPT-42	317	1200	97	2464	36	914	6	152	10¼	260	30	762	1720	780
SPT-50	370	1400	110	2794	36	914	6	152	10¼	260	30	762	1900	862
SPT-56	422	1600	86	2184	48	1219	8	203	12¼	311	42	1067	2300	1043
SPT-70	528	2000	100	2540	48	1219	8	203	12¼	311	42	1067	2700	1225

All dimensions and weights are approximate. *FM Approved only.

Job Name _____	Notes _____
Engineer _____	_____
Contractor _____	_____
P.O. No. _____	_____
Sales Rep. _____	_____
Model No. _____	_____

