



WELL-X-TROL®

Diaphragm Well Tanks: WX-400C Series ASME

300 PSIG Working Pressure

Construction

Shell	ASME Approved Steel
Diaphragm	Heavy Duty Butyl
Liner	Antimicrobial Polypropylene w/ Anti-Legionella Protection
System Connection	Malleable Iron (NPTF)
Finish	Red Oxide Primer
Water Circulator	Turbulator®
Air Valve	Schrader Valve w/EPDM Seat
Factory Precharge	25 PSIG (1.7 bar)

Performance

Maximum Operating Temperature	200°F (93°C)
Maximum Working Pressure	300 PSIG (20.7 bar)
Warranty	3-Years

Application

- For use in commercial well water and booster pump systems.
- Fixed diaphragm construction.
- Designed and constructed per ASME Code Section VIII, Division 1.
- Tested to JIS Z 2801 for reduction of Legionella, Staphylococcus and E. coli.
- Follows ASHRAE 188 Anti-Legionella guidelines.
- Sight glass and seismic restraint options available.

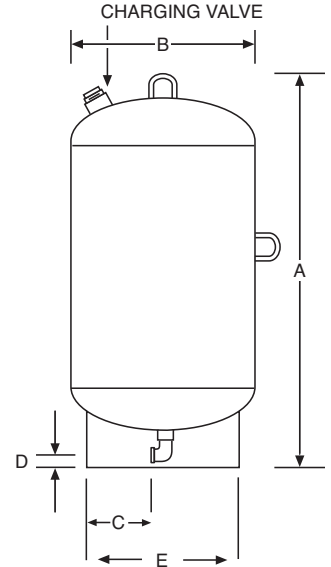

ASME Models

Model Number	Tank Volume		Max. Accept. Volume		A Tank Height		B Tank Diameter		C Sys. Conn. Inset		D Sys. Conn. Centerline		E Stand Diameter		System Conn. (NPTF)	Shipping Weight	
	Gal	Lit	Gal	Lit	In	mm	In	mm	In	mm	In	mm	In	mm		Lbs	Kg
WX-401C	18	68	11	42	31	787	16	406	5	124	1½	38	12¾	324	1	133	60
WX-402C	25	95	11	42	40	1016	16	406	5	124	1½	38	12¾	324	1	160	73
WX-403C	34	129	11	42	49	1245	16	406	5	124	1½	38	12¾	324	1	200	91
WX-404C	68	258	34	129	48	1219	24	610	6	159	1⅝	41	16	406	1¼	432	196
WX-405C	90	341	34	129	59	1499	24	610	6	159	1⅝	41	16	406	1¼	460	209
WX-406C	110	417	34	129	70	1778	24	610	6	159	1⅝	41	16	406	1¼	500	227
WX-407C	132	500	46	175	57	1448	30	762	10	254	1¾	44	24	610	1¼	625	284

All dimensions and weights are approximate.

Job Name _____	Notes _____
Engineer _____	_____
Contractor _____	_____
P.O. No. _____	_____
Sales Rep. _____	_____
Model No. _____	_____



Certified to NSF/ANSI CAN 61

