



WELL-X-TROL®

Partial Acceptance Bladder Well Tanks: WX Series ASME

125 PSIG Working Pressure

Construction

| | |
|------------------------------------|------------------------------|
| Shell | ASME Approved Steel |
| Bladder Material | Heavy Duty Butyl |
| Bladder Thickness (models 35-100) | .087 In. Minimum |
| Bladder Thickness (models 130-600) | .100 In. Minimum |
| System Connection | Malleable Iron (NPTF) |
| Finish | Red Oxide Primer |
| Air Valve | Schrader Valve w/ EPDM Seats |
| Factory Precharge | 25 PSIG (1.7 bar) |

Performance

| | |
|-------------------------------|--------------------|
| Maximum Operating Temperature | 240°F (115°C) |
| Maximum Working Pressure | 125 PSIG (8.6 bar) |
| Warranty | 3-Years |

Application

- For use in commercial well water and booster pump systems.
- Replaceable bladder design.
- Sight glass and seismic restraint options available.
- Designed and constructed per ASME Code Section VIII, Division 1.,

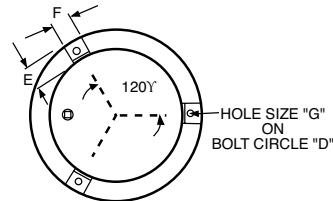

BOTTOM VIEW

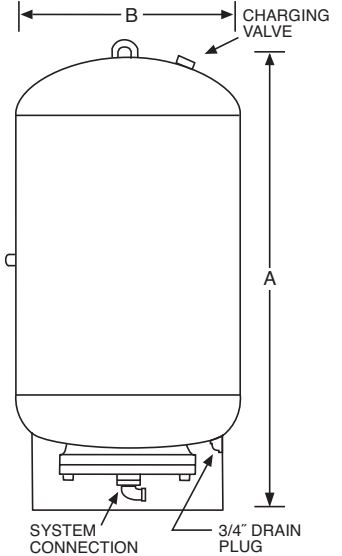

ASME Models

| Model Number | Tank Volume | | Max. Accept. Volume | | A Tank Height | | B Tank Diameter | | System Conn. (NPTF) | Shipping Weight | |
|--------------|-------------|-----|---------------------|-----|---------------|------|-----------------|-----|---------------------|-----------------|-----|
| | Gal | Lit | Gal | Lit | In | mm | In | mm | | In | Lbs |
| WX-35CL | 10 | 35 | 10 | 35 | 37 | 941 | 10 | 254 | 1¼ | 69 | 32 |
| WX-50CL | 13 | 50 | 11 | 40 | 37 | 941 | 12 | 305 | 1¼ | 76 | 35 |
| WX-85CL | 22 | 85 | 11 | 40 | 35 | 889 | 16 | 406 | 1¼ | 92 | 42 |
| WX-100CL | 26 | 100 | 11 | 40 | 39 | 991 | 16 | 406 | 1¼ | 98 | 45 |
| WX-130CL | 34 | 130 | 27 | 100 | 35 | 889 | 20 | 508 | 1½ | 136 | 62 |
| WX-165CL | 44 | 165 | 27 | 100 | 40 | 1016 | 20 | 508 | 1½ | 146 | 67 |
| WX-200CL | 53 | 200 | 27 | 100 | 41 | 1041 | 24 | 610 | 1½ | 198 | 91 |
| WX-300CL | 80 | 300 | 27 | 100 | 56 | 1423 | 24 | 610 | 1½ | 236 | 108 |
| WX-400CL | 106 | 400 | 53 | 200 | 69 | 1743 | 24 | 610 | 2 | 282 | 129 |
| WX-500CL | 132 | 500 | 53 | 200 | 83 | 2108 | 24 | 610 | 2 | 316 | 144 |
| WX-600CL | 158 | 600 | 53 | 200 | 67 | 1702 | 30 | 762 | 2 | 450 | 206 |

All dimensions and weights are approximate.

Optional Seismic Restraints

| Tank Diameter | Bolt Circle | Dim. | Dim. | Hole Size |
|---------------|-------------|------|------|-----------|
| B | D | E | F | G |
| 10 | 12½ | 2 | 2 | 9/16 |
| 12 | 14¾ | 2 | 2 | 9/16 |
| 16 | 14¾ | 2 | 2 | 9/16 |
| 20 | 14¾ | 2 | 2 | 9/16 |
| 24 | 18 | 2 | 2 | 9/16 |
| 30 | 21½ | 3 | 3 | ¾ |

| | |
|------------------|-------------|
| Job Name _____ | Notes _____ |
| Engineer _____ | _____ |
| Contractor _____ | _____ |
| P.O. No. _____ | _____ |
| Sales Rep. _____ | _____ |
| Model No. _____ | _____ |

