



THERM-X-TROL®

Thermal Expansion Tanks: Partial Acceptance Bladder ST Series ASME

150 PSIG Working Pressure

Construction

Shell	Carbon Steel
Bladder Material	Heavy Duty Butyl
Bladder Thickness (models 35-100)	.087 In Minimum
Bladder Thickness (models 130-600)	.100 In Minimum
System Connection	Stainless Steel
Finish	Red Oxide Primer
Air Valve	Schrader Valve w/ EPDM Seat
Factory Precharge	25 PSIG (1.7 bar)

Application

- For use in closed, potable water systems to control pressure build-up.
- Partial acceptance replaceable bladder design.
- Optional sight glass and seismic restraints available.
- Designed and constructed per ASME Code Section VIII, Division 1.

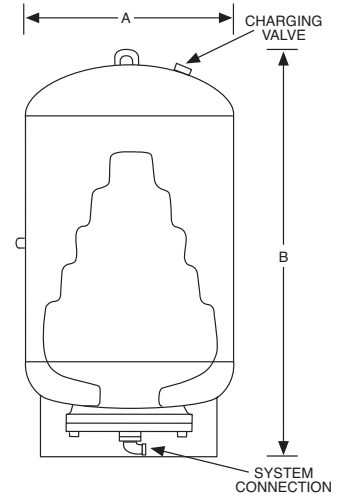

Performance

Maximum Operating Temperature	240°F (115°C)
Maximum Working Pressure	150 PSIG (10.3 bar)
Warranty	3-Years

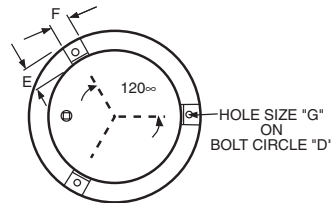

BOTTOM VIEW

ASME Models

Model Number	Tank Volume		Max. Accept. Factor	A Tank Diameter		B Tank Height		System Conn. (NPTF)	Shipping Weight	
	Gal	Lit		In	mm	In	mm		Lbs	Kg
ST-35CL	10	35	1.00	10	254	37	948	1	76	34
ST-50CL	13	50	.85	12	305	37	941	1	78	35
ST-85CL	22	85	.50	16	406	35	872	1	95	43
ST-100CL	26	100	.42	16	406	39	991	1	102	46
ST-130CL	34	130	.79	20	508	35	881	1	134	61
ST-165CL	44	165	.61	20	508	40	1008	1	153	69
ST-200CL	53	200	.51	24	610	41	1039	1	205	93
ST-300CL	80	300	.34	24	610	56	1423	1	254	115
ST-400CL	106	400	.50	24	610	69	1743	1	308	140
ST-500CL	132	500	.40	24	610	83	2096	1	352	160
ST-600CL	158	600	.34	30	762	67	1702	1	442	200

Optional Seismic Restraints

Tank Diameter	Bolt Circle	Dim. E	Dim. F	Hole Size
B	D	E	F	G
10	12 ⁵ / ₈	2	2	¹ / ₁₆
12	14 ³ / ₄	2	2	¹ / ₁₆
16	16 ³ / ₄	2	2	¹ / ₁₆
20	16 ³ / ₄	2	2	¹ / ₁₆
24	18	2	2	¹ / ₁₆
30	22 ³ / ₄	3	3	³ / ₄

All dimensions and weights are approximate.

Job Name _____	Notes _____
Engineer _____	_____
Contractor _____	_____
P.O. No. _____	_____
Sales Rep. _____	_____
Model No. _____	_____

