



COMPRESSION TANKS

AC Series ASME

Construction

Shell	ASME Approved Carbon Steel
Diaphragm	N/A
Liner Material	N/A
Finish	Red Oxide primer

Performance

Maximum Operating Temperature	450°F (115°C)
Maximum Working Pressure	150 PSIG 15-60 gallon 125 PSIG 80-525 gallon
Warranty	3-Years

Application

- For use in closed, non-potable hydronic heating and chilled water systems.
- Designed and constructed per ASME Code Section VIII, Division 1.

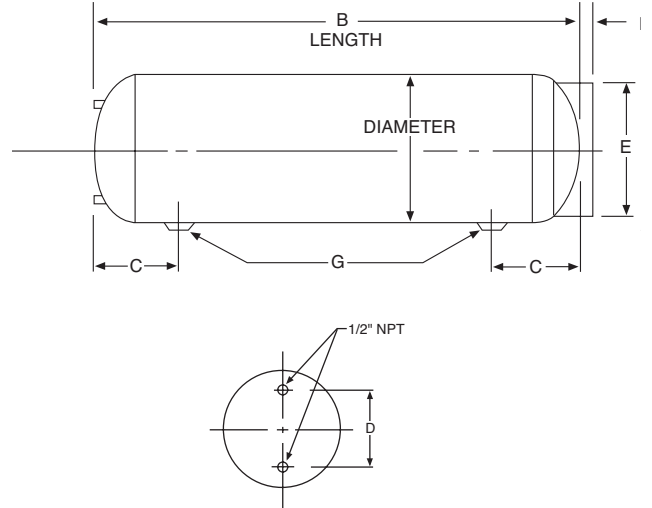

AC Series - Plain Steel

Model Number	Tank Volume		A Tank Diameter		B Tank Length		C	D	E	F	G	Shipping Weight	
	Gal	Lit	In	mm	In	mm						In	Lbs
AC12-15	15	57	12	305	33	383	7	8	11½	7/8	1	44	20
AC12-24	24	91	12	305	51	1295	7	8	11½	7/8	1	62	28
AC14-30	30	114	14	356	48	1219	8¾	10	11½	1⅛	1	72	33
AC14-40	40	151	14	356	63	1600	8¾	10	11½	1⅛	1	92	42
AC16-60	60	227	16	406	72	1829	9¼	12	11½	1½	1	120	54
AC20-80	80	303	20	508	63	1600	10	16	18	1½	1	136	62
AC20-100	100	379	20	508	78	1981	10	16	18	1½	1	168	76
AC24-120	120	454	24	610	65	1651	11⅞	20	18	1½	1	218	99
AC24-135	135	511	24	610	72	1829	11⅞	20	18	1½	1	238	108
AC30-175	175	662	30	762	62	1575	13½	22	18	1½	1	338	153
AC30-220	220	833	30	762	77	1956	13½	22	24	2	1½	368	167
AC30-240	240	908	30	762	84	2134	13½	22	24	2	1½	394	179
AC30-305	305	1155	30	762	106	2692	13½	22	24	2	1½	486	220
AC36-400	400	1514	36	914	93	2362	14¾	28	30	2½	1½	645	293
AC36-505*	505	1912	36	914	120	3048	14¾	28	-	-	1½	810	367

*Ring stand not provided on 505 gallon tanks
All dimensions and weights are approximate.

Job Name _____	Notes _____
Engineer _____	_____
Contractor _____	_____
P.O. No. _____	_____
Sales Rep. _____	_____
Model No. _____	_____

