

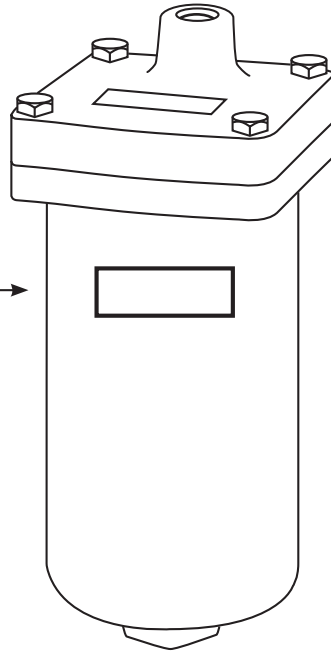

HIGH CAPACITY AIR VENT INSTALLATION & OPERATION INSTRUCTIONS

Model 747

Warning Label Part No. V56845
installed in this location.
If missing, it must be replaced.



NOTE: Inspect for shipping damage and notify freight carrier or store where purchased immediately if damage is present. To avoid risk of personal injury and property damage, if the product appears to be malfunctioning or shows signs of corrosion, call a licensed professional immediately. Current copies of the Product manual can be viewed at www.amtrol.com. Use proper safety equipment when installing.



THIS IS THE SAFETY ALERT SYMBOL. IT IS USED TO ALERT YOU TO POTENTIAL PERSONAL INJURY AND OTHER HAZARDS. OBEY ALL SAFETY MESSAGES THAT FOLLOW THIS SYMBOL TO REDUCE THE RISK OF PERSONAL INJURY AS WELL AS PROPERTY DAMAGE.

WARNING Read carefully the product Installation & Operation Instructions to avoid serious personal injury and property hazards and to ensure safe use and proper care of this product.

WARNING **EXPLOSION OR RUPTURE HAZARD** The High Capacity Air Vent must be operated so that the pressure does not exceed the maximum operating pressure.

CAUTION The generous use of pipe joint compound when installing 747 High Capacity Air Vent will foul the vent's operating mechanism allowing water to escape. Pipe joint compound must be conservatively applied to male threads only. Failure to follow this instruction can result in personal injury from hot water and/or property damage.

CAUTION The use of Teflon impregnated pipe compound and Teflon tape on pipe threads provides lubricity which can lead to overtightening and breakage. Do not overtighten. Failure to follow this instruction can result in personal injury from hot water and/or property damage.

CAUTION When the vent discharges air or if foreign material from the system fouls the vent's operating mechanism, it is possible for water to also be discharged. Vent must be piped to a drain. Failure to follow this instruction can result in personal injury from hot water and/or property damage.

WARNING **THIS PRODUCT MUST BE INSTALLED BY A LICENSED PROFESSIONAL.**

WARNING This product, like all pressure vessels, can, over time, corrode, fail, leak and flood. **DO NOT LOCATE** in an area where water from the air vent can cause property damage.

WARNING This product can expose you to chemicals including lead, which is known to the State of California to cause cancer and birth defects or other reproductive harm. For more information go to www.P65Warnings.ca.gov.

PLEASE READ THE FOLLOWING INSTRUCTIONS CAREFULLY
IMPORTANT GENERAL SAFETY INFORMATION -
ADDITIONAL SPECIFIC SAFETY ALERTS APPEAR IN THE FOLLOWING INSTRUCTIONS.

Description

The AMTROL Model 747 High Capacity Air Vent is designed for use in liquid systems to purge undesirable free air that otherwise could impede system performance, increase system operating cost and contribute to the damaging effects of corrosion. The accumulation of air in the body of the Model 747 High Capacity Air Vent causes a float to drop allowing the air to be vented through an air eliminating orifice. As the liquid level rises in the vent body, the float also rises, shutting off the flow of venting gases.

Installation Instructions

1. Install the Model 747 Vent in a location where air is expected to collect or where it is desirable to prevent air accumulation. See typical applications on back page.
2. Install the Model 747 High Capacity Air Vent with its vent connection in the top vertical position.

Temperature and Pressure Limits

Maximum Operating Temperature: 250°F (121°C)

Minimum Operating Temperature: 35°F (1.6°C) unless used with liquid other than water.

Maximum Operating Pressure: 150 psig (10.5 bar)

Operating Instructions

CAUTION Liquids and additives such as hydrocarbons, which are aggressive to the EPDM elastomer seals used in the 747 Air Vent, can cause the seals to fail and allow uncontrolled discharge of system fluid. Do not use the 747 Air Vent on systems utilizing such fluids or additives. Failure to follow this instruction can result in personal injury from hot water and/or property damage.

WARNING The model 747 Air Vent will discharge air and possibly some liquid during its normal functioning. Avoid eye, face or skin contact with top area of Air Vent. AMTROL recommends the vent connection be piped to a drain to prevent accidental contact with discharging fluids. Failure to follow this instruction can result in serious personal injury and /or property damage.

Service Instructions

WARNING Corrosion or leakage are indications that the 747 Air Vent may be at the end of its useful life or requires maintenance. It should be periodically inspected and if corrosion or leakage is noted, 747 Air Vent must be replaced or serviced. Failure to follow this instruction can result in serious personal injury and/or property damage.

If model 747 Air Vent does not shutoff after air has been vented off, the seat button may be replaced as follows:

WARNING System fluid under pressure and /or at high temperatures can be very hazardous. Before servicing, reduce system pressure to zero or isolate the 747 Air Vent from the system. Allow system to cool below 100°F. Failure to follow this instruction can result in serious personal injury and/or property damage.

1. Remove the four cap screws that attach the cover to the body. (Item 1, Fig.1)
2. Remove the cover from the body making sure not to damage the gasket surfaces on the cover or the body. (Item 2, Fig. 1)
3. Inspect the rubber button and its mating seating surface for damage or foreign material. (Items 3 & 4, Fig. 1 or 2) If the rubber button is damaged or has deteriorated, the lever and button assembly must be replaced.
4. The spring lever and button assembly is removed by pulling the outer wires of the spring lever out of the holes in the seat yoke. (Items 5 & 8, Fig. 2) (See Fig. 1 Note). Next, remove the spring lever and button assembly from the float by pulling it through the retaining hooks. (Item 6, Fig. 1 or 2).
5. Reverse the procedure in (4) above to install a new lever and button assembly. If the seat yoke has two sets of holes install the lever in the smaller off center holes. (See Fig. 3)
6. Thoroughly clean gasket surfaces and install a new gasket. (Item 7, Fig. 1)
7. Place cover assembly back in place on the body. Replace cap screws and tighten in a criss cross pattern to 20 ft-lbs. of torque.
8. Open any shutoff valves and return the system to normal operation.
9. Check for gasket leaks. Retighten bolts or replace gasket if necessary.

Warranty

Air Vent Model 747: One (1) Year Limited Warranty

Visit www.amtrol.com for complete warranty details.

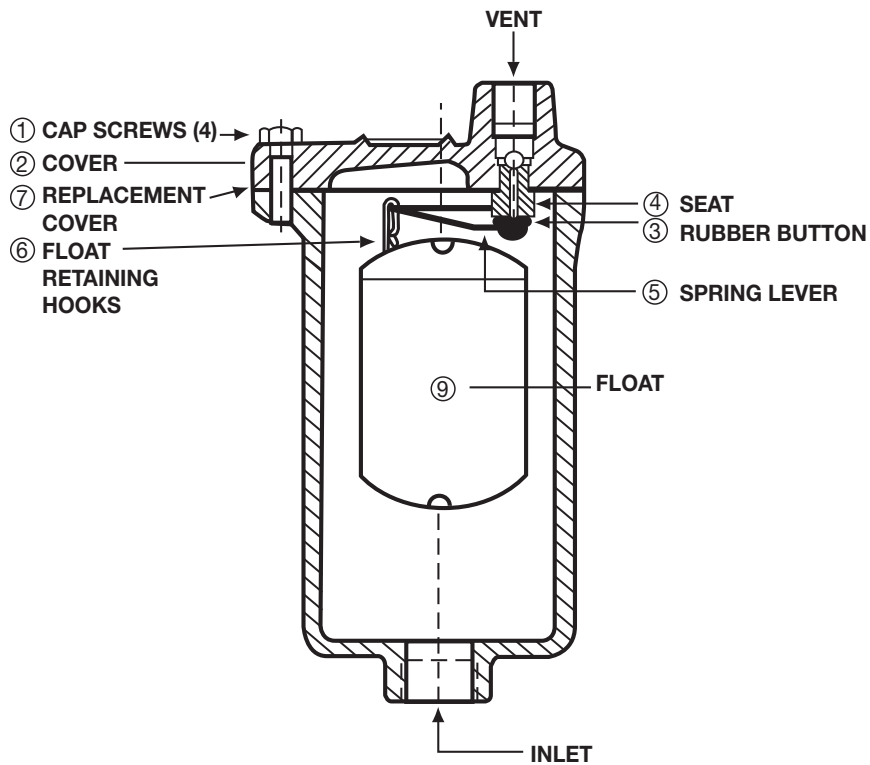

FIG. 1

NOTE: On some air vents, the ends of the spring lever have been welded to produce a restraining bead. To remove these spring levers it is necessary to cut the spring lever. The replacement spring lever will not have these welds and they are necessary only for shipment purposes.

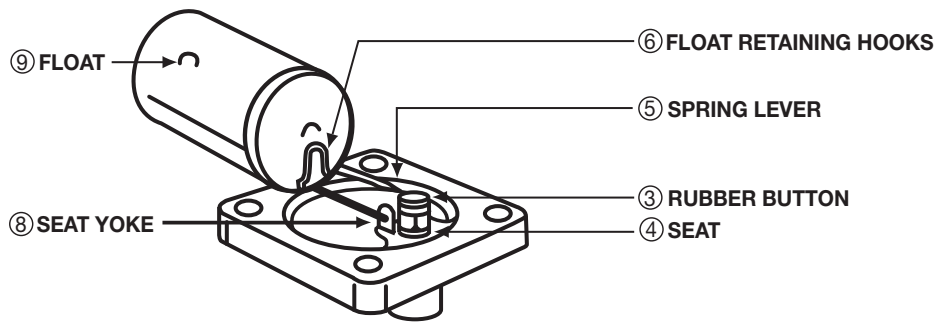

FIG. 2

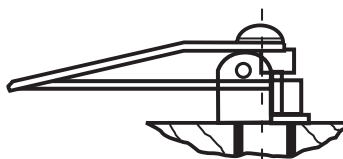
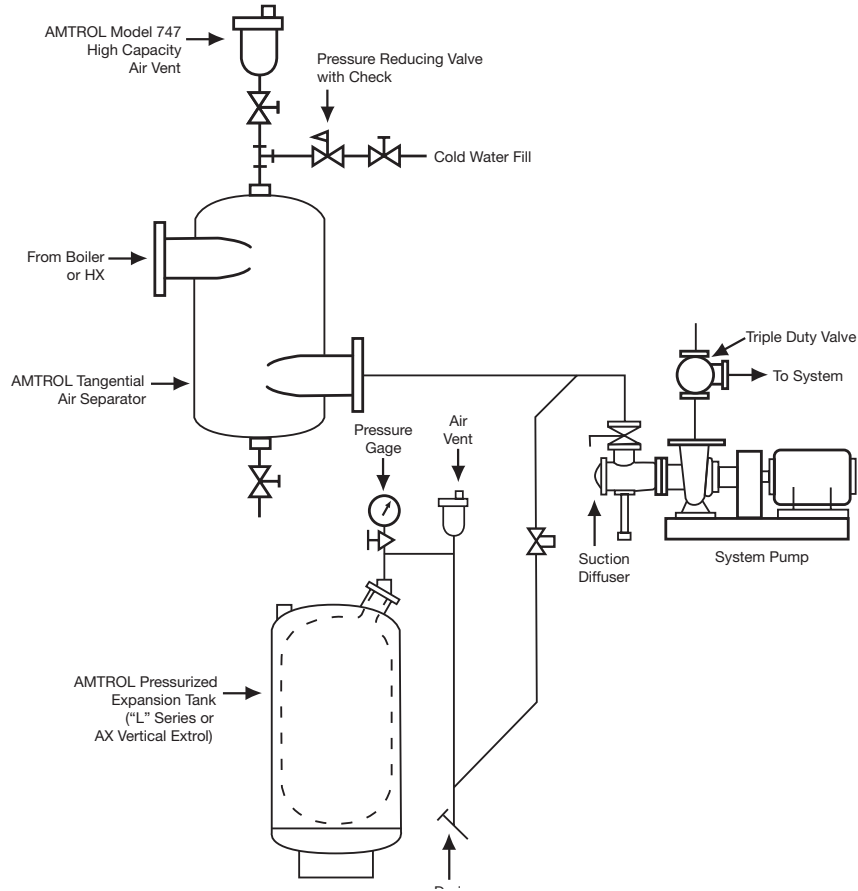

FIG. 3

TYPICAL HYDRONIC HEATING/COOLING APPLICATIONS

Amtrol Extrol® Vertical Expansion Tank



Amtrol Extrol® Horizontal Expansion Tank

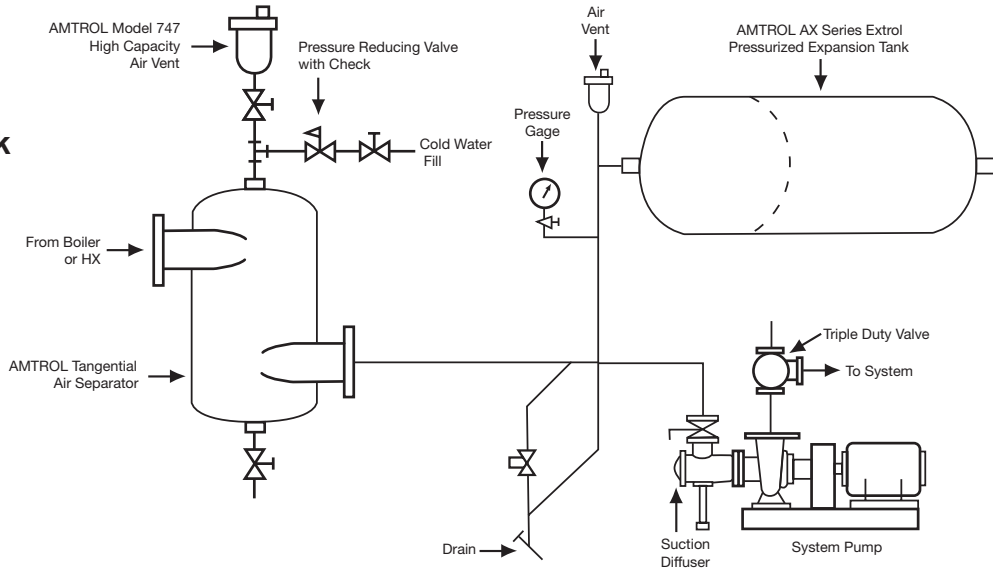

1400 Division Road, West Warwick, RI 02893 USA
T: 800.426.8765 www.amtrol.com

