



AIR & DIRT SEPARATORS

FOR CLOSED HYDRONIC HEATING AND CHILLED WATER SYSTEMS

INSTALLATION & OPERATION INSTRUCTIONS

Models 2-ADS through 12-ADS
Including Magnetic Separator Option



NOTE: Inspect for shipping damage and notify freight carrier or store where purchased immediately if damage is present. To avoid risk of personal injury and property damage, if the product appears to be malfunctioning or shows signs of corrosion, call a licensed professional immediately. Current copies of the Product manual can be viewed at www.amtrol.com. Use proper safety equipment when installing.



THIS IS THE SAFETY ALERT SYMBOL. IT IS USED TO ALERT YOU TO POTENTIAL PERSONAL INJURY AND OTHER HAZARDS. OBEY ALL SAFETY MESSAGES THAT FOLLOW THIS SYMBOL TO REDUCE THE RISK OF PERSONAL INJURY AS WELL AS PROPERTY DAMAGE.

WARNING READ CAREFULLY THE PRODUCT INSTALLATION & OPERATION INSTRUCTIONS. FAILURE TO FOLLOW THE INSTRUCTIONS AND WARNINGS IN THE MANUAL MAY RESULT IN SERIOUS OR FATAL INJURY AND/OR PROPERTY DAMAGE, AND WILL VOID THE PRODUCT WARRANTY. THIS PRODUCT MUST BE INSTALLED BY A LICENSED PROFESSIONAL. FOLLOW ALL APPLICABLE LOCAL AND STATE CODES AND REGULATIONS, IN THE ABSENCE OF SUCH CODES, FOLLOW THE CURRENT EDITIONS OF THE NATIONAL PLUMBING CODE AND NATIONAL ELECTRIC CODE, AS APPLICABLE.

WARNING EXPLOSION OR RUPTURE HAZARD. THE TANK MUST BE OPERATED SO THAT THE PRESSURE DOES NOT EXCEED THE MAXIMUM WORKING PRESSURE.

WARNING Use only lead-free solder and flux for all sweat-solder connections, as required by state and federal codes.

WARNING This Product, like most Products under pressure, may over time corrode, weaken and burst or explode, causing serious or fatal injury, leaking or flooding and/or property damage. To minimize risk, a licensed professional must install and periodically inspect and service the Product. A drip pan connected to an adequate drain must be installed if leaking or flooding could cause property damage. Do not locate in an area where leakage of the tank or connections could cause property damage to the area adjacent to the appliance or to lower floors of the structure.

WARNING This product can expose you to chemicals including lead, which is known to the State of California to cause cancer and birth defects or other reproductive harm. For more information go to www.P65Warnings.ca.gov.

PLEASE READ THE FOLLOWING INSTRUCTIONS CAREFULLY

IMPORTANT GENERAL SAFETY INFORMATION - ADDITIONAL SPECIFIC SAFETY ALERTS APPEAR IN THE FOLLOWING INSTRUCTIONS.

WARNING THIS PRODUCT MUST BE INSTALLED BY A LICENSED PROFESSIONAL.

Installation

1. Refer to Figure 1 for proper installation of the Amtrol ADS.

WARNING Wet weight of the separator can exceed strength of supports. Make sure provisions are made to support the wet weight and not just the dry weight (see weight chart below). Failure to follow these instructions may result in serious or fatal personal injury and/or property damage.

2. ADS Series Separators can be supported in the piping system as long as pipe hangers are attached to the nozzles as close to the unit's shell as possible.

WARNING Welding to the pressure vessel boundary will void the ASME rating.

3. A blowdown valve should be added to the blowdown connection at the bottom of the tank. The function of the blowdown valve is to facilitate the purging of sediment from the vessel.

An automatic, float-type air vent needs to be installed on the top connection of the separator. Install with at least 30" of clearance below unit.

Maintenance

A licensed professional should check the complete system, including the air separator, yearly and more frequently as the system ages.

WARNING Leakage, corrosion or indications of damage are signs of an impending serious failure of the air separator. Periodically inspect for damage and, if noted, the separator must be serviced or replaced immediately. Failure to follow these instructions may result in serious or fatal personal injury and/or property damage.

Sediment should be purged from the vessel periodically. This is particularly true during the initial start-up period. During each purge cycle, note the condition of the water to determine a regular blowdown interval. The need to purge sediment from the vessel may be evidenced by a high pressure drop across the separator or by pump cavitation problems. To clean the separator:

1. Allow the system water temperature to cool below 100°F.

WARNING Water temperature above 100°F can be very hazardous. Allow system water temperature to cool down below 100°F before blowing down the separator. Failure to follow these instructions may result in serious or fatal personal injury and/or property damage.

2. Magnetic Option only: (Figure 2) Unscrew and remove the Magnetic rod. Place rod on a nonmetallic surface, away from dirt and metal objects.

WARNING Can be harmful to pacemaker and ICD wearers. Stay at least 12" away. Magnet exerts strong forces on metallic objects. Tools, magnets and metal objects can cut, pinch and entrap hands and fingers. HANDLE WITH CAUTION!

3. Operate the blowdown valve for a few seconds. This should dislodge accumulated dirt from the vessel. Start by closing the isolation valve to isolate the separator from the system. Open the blowdown valve on the bottom of the separator to drain the unit. Make sure that all of the flow from the blowdown valve has stopped. If water continues to flow, the isolation valve must be repaired or replaced before proceeding.

WARNING System fluid under pressure and/or high temperature can be very hazardous. Before proceeding, reduce system pressure to zero and isolate the separator from the system. Allow system temperature to cool below 100°F. Failure to follow these instructions may result in serious or fatal personal injury and/or property damage.

Suggested Piping Diagrams

Figure 1

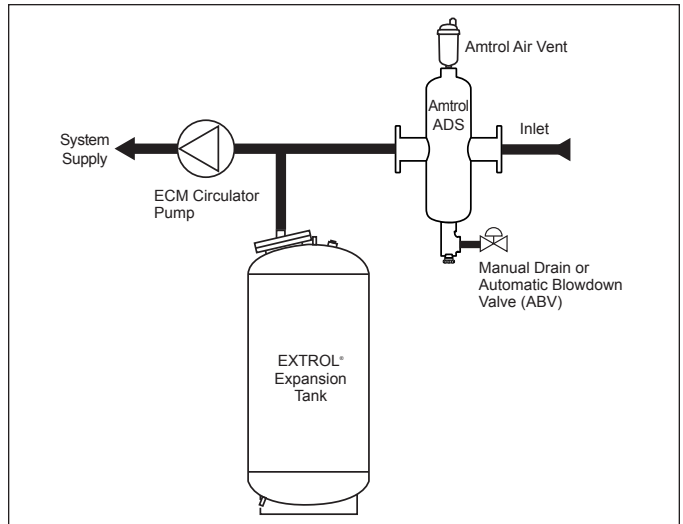
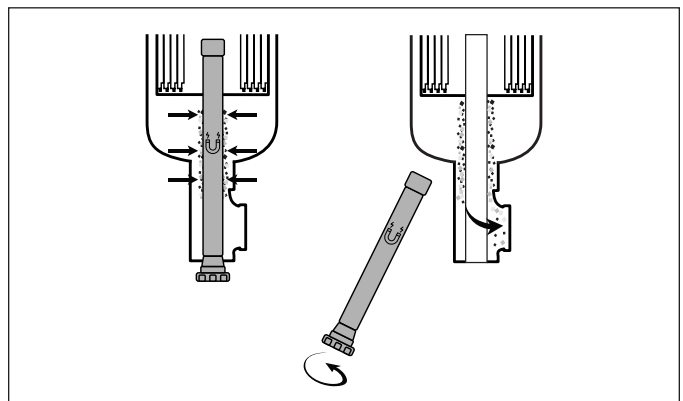

Figure 2



Weight Chart (150 PSI)		
Model Number	Dry Weight (lbs)	Wet Weight (lbs)
2-ADS	65	90
3-ADS	97	152
4-ADS	110	170
5-ADS	154	324
6-ADS	159	334
8-ADS	270	630
10-ADS	395	995
12-ADS	550	1745

Magnetic option adds 10 lbs. (5kg.)

Warranty

ADS Series Models: Three (3) Year Limited Warranty
Visit www.amtrol.com for complete warranty details.



1400 Division Road, West Warwick, RI 02893 USA
T: 800.426.8765 www.amtrol.com

