

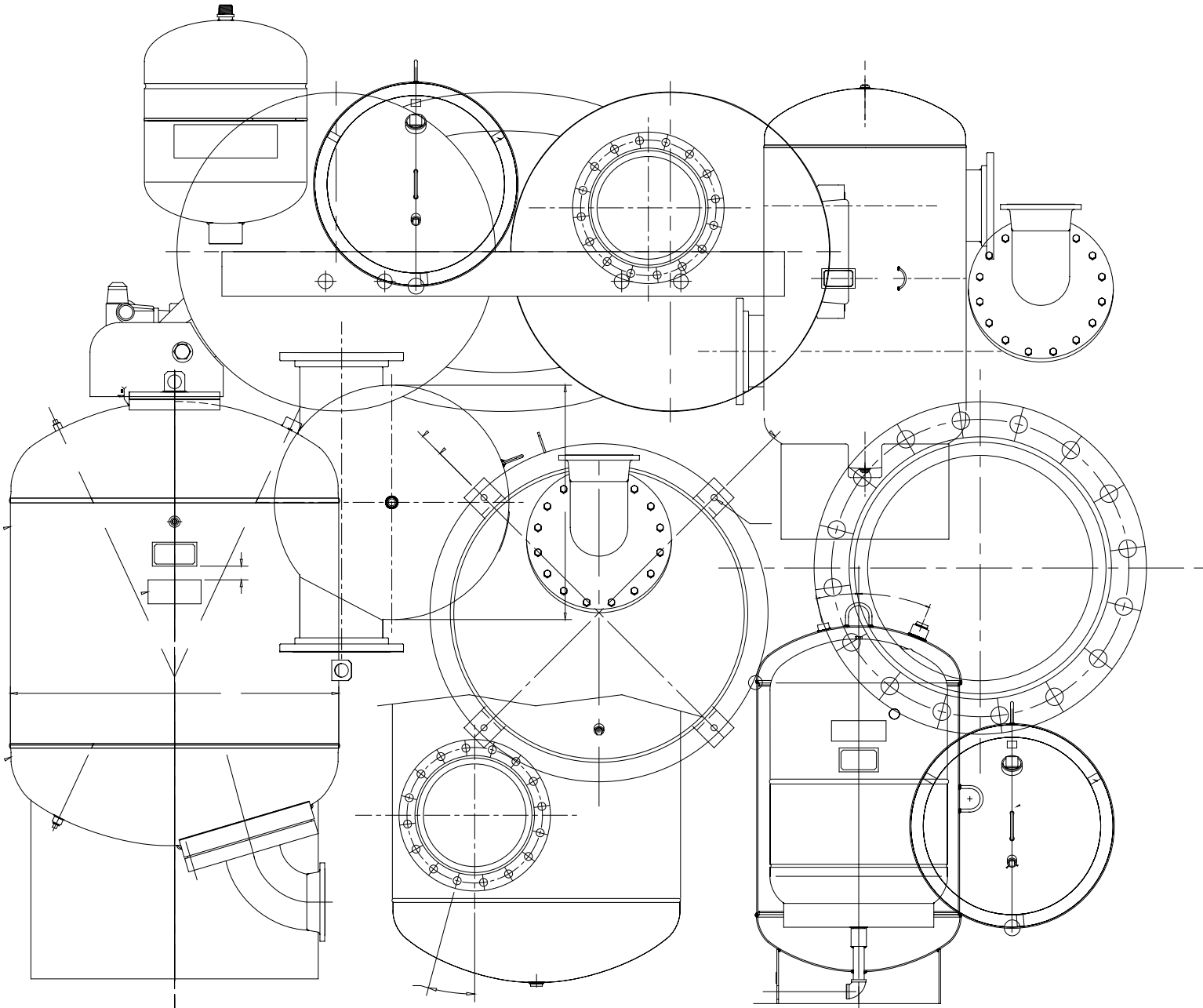

SUBMITTAL DATA

Product Information and Specifications





WELL-X-TROL®

Diaphragm Well Tanks: WX-100, 200 and 300 Series

150 PSIG Working Pressure

Construction

Shell	High Strength Steel
Diaphragm	Heavy Duty Butyl
Liner	Antimicrobial
System Connection	Stainless Steel
Finish	Tuf-Kote™ HG Blue
Water Circulator	Turbulator®
Air Valve	Projection Welded
Factory Precharge	38 PSIG (2.6 bar)

Performance

Maximum Operating Temperature	200°F (93°C)
Maximum Working Pressure	150 PSIG (10.3 bar)
Maximum Relief Valve Setting	125 PSIG (8.6 bar)
Warranty	7-Years

Application

- Controls pump cycling in residential well water systems.
- Can be installed indoors or outdoors.

In-Line Models

Model Number	Tank Volume		Max. Acceptance Factor	A Tank Height		B Tank Diameter		System Connection (NPTM)	Shipping Weight	
	Gal	Lit		In	mm	In	mm		Lbs	Kg
WX-101	2.0	8	0.45	13	330	8	203	3/4	5	2
WX-102	4.4	17	0.55	15	381	11	279	3/4	9	4
WX-103	6.7	25	0.40	20	508	11	279	3/4	13	6
WX-104	10.3	39	1.00	18	457	15	381	1	20	9
WX-200	14.0	53	0.81	22	559	15	381	1	22	10

Available in gray. Use suffix G.

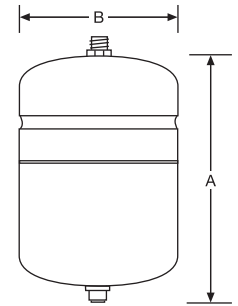

Stand Models

Model Number	Tank Volume		Max. Accept. Factor	A Tank Height		B Tank Diameter		C Sys. Conn. Centerline		D Stand Diameter		System Conn. (NPTF)	Shipping Weight	
	Gal	Lit		In	mm	In	mm	In	mm	In	mm		Lbs	Kg
WX-201	14.0	53	0.81	25	635	15	381	1 19/32	40	12	304	1	25	11
WX-202	20.0	76	0.57	32	813	15	381	1 19/32	40	12	304	1	32	15
WX-202XL	26.0	98	0.44	39	991	15	381	1 19/32	40	12	304	1	39	18
WX-203	32.0	121	0.35	47	1194	15	381	1 19/32	40	12	304	1	47	21
WX-205	34.0	129	1.00	30	762	22	559	1 15/16	49	20 1/2	521	1 1/4	57	26
WX-250	44.0	167	0.77	36	914	22	559	1 15/16	49	20 1/2	521	1 1/4	65	29
WX-251	62.0	235	0.55	47	1194	22	559	1 15/16	49	20 1/2	521	1 1/4	87	39
WX-255	81.0	306	0.41	57	1448	22	559	1 15/16	49	20 1/2	521	1 1/4	109	49
WX-302	86.0	326	0.54	47	1194	26	660	2 1/16	52	20 1/2	521	1 1/4	106	48
WX-350	119.0	450	0.39	62	1575	26	660	2 1/16	52	20 1/2	521	1 1/4	146	66

Available in Blue only. Available in Tan and Gray. Use suffix T or G.

All dimensions and weights are approximate.

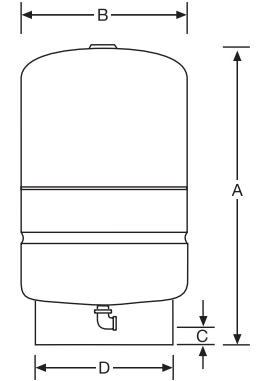

Job Name _____	Notes _____
Engineer _____	_____
Contractor _____	_____
P.O. No. _____	_____
Sales Rep. _____	_____
Model No. _____	_____





WELL-X-TROL®

Diaphragm Well Tanks: WX-100, 200 and 300 Series with DuraBase®

150 PSIG Working Pressure

Construction

Shell	High Strength Steel
Diaphragm	Heavy Duty Butyl
Liner	Antimicrobial
System Connection	Stainless Steel
Finish	Tuf-Kote™ HG Blue
Water Circulator	Turbulator®
Air Valve	Projection Welded
Factory Precharge	38 PSIG (2.6 bar)

Performance

Maximum Operating Temperature	200°F (93°C)
Maximum Working Pressure	150 PSIG (10.3 bar)
Maximum Relief Valve Setting	125 PSIG (8.6 bar)
Warranty	7-Years

Application

- Controls pump cycling in residential well water systems.
- Can be installed indoors or outdoors.
- DuraBase stand is rugged and will never corrode. Patented.

Stand Models

Model Number	Tank Volume		Max. Accept. Factor	A Tank Height		B Tank Diameter		C Sys. Conn. Centerline		D Stand Diameter		System Conn. (NPTF)	Shipping Weight	
	Gal	Lit		In	mm	In	mm	In	mm	In	mm		Lbs	Kg
WX-201D	14.0	53	0.81	25	635	15	381	1 ¹¹ / ₁₆	43	15 ³ / ₈	391	1	25	11
WX-202D	20.0	76	.057	32	813	15	381	1 ¹¹ / ₁₆	43	15 ³ / ₈	391	1	32	15
WX-202XLD	26.0	98	0.44	39	991	15	381	1 ¹¹ / ₁₆	43	15 ³ / ₈	391	1	39	18
WX-203D	32.0	121	0.35	47	1194	15	381	1 ¹¹ / ₁₆	43	15 ³ / ₈	391	1	47	21
WX-205D	34.0	129	1.00	30	762	22	559	2	51	22	559	1 ¹ / ₄	57	26
WX-250D	44.0	167	0.77	36	914	22	559	2	51	22	559	1 ¹ / ₄	65	29
WX-251D	62.0	235	0.55	47	1194	22	559	2	51	22	559	1 ¹ / ₄	87	39
WX-255D	81.0	306	0.41	57	1448	22	559	2	51	22	559	1 ¹ / ₄	109	49
WX-302D	86.0	326	0.54	47	1194	26	660	2	51	22	559	1 ¹ / ₄	106	48
WX-350D	119.0	450	0.39	62	1575	26	660	2	51	22	559	1 ¹ / ₄	146	66

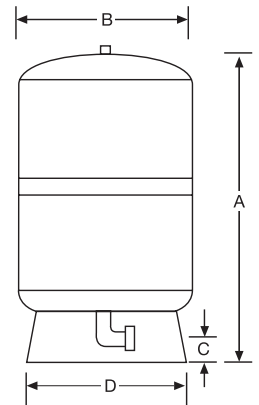

Available in Tan and Gray. Use suffix T or G.

All dimensions and weights are approximate.

Job Name _____	Notes _____
Engineer _____	_____
Contractor _____	_____
P.O. No. _____	_____
Sales Rep. _____	_____
Model No. _____	_____





WELL-X-TROL®

Diaphragm Well Tanks: Underground, Wall Hung and Pump Stand Series

150 PSIG Working Pressure

Construction

Shell	High Strength Steel
Diaphragm	Heavy Duty Butyl
Liner	Antimicrobial
System Connection	Stainless Steel
Finish	Tuf-Kote™ HG Blue
Water Circulator	Turbulator®
Air Valve	Projection Welded
Factory Precharge	38 PSIG (2.6 bar)

Performance

Maximum Operating Temperature	200°F (93°C)
Maximum Working Pressure	150 PSIG (10.3 bar)
Maximum Relief Valve Setting	125 PSIG (8.6 bar)
Warranty	7-Years

Application

- Controls pump cycling in residential well water systems.

Underground Models (BLACK)

Model Number	Tank Volume		Max. Acceptance Factor	A Tank Height		B Tank Diameter		System Connection (NPTF)	Shipping Weight	
	Gal	Lit		In	mm	In	mm		Lbs	Kg
WX-200UG	14	53	0.81	23	584	15	381	1	22	10
WX-202UG	20	76	0.57	30	762	15	381	1	30	14
WX-250UG	44	167	0.77	33	838	22	559	1¼	60	27
WX-251UG	62	235	0.55	44	1118	22	559	1¼	83	38

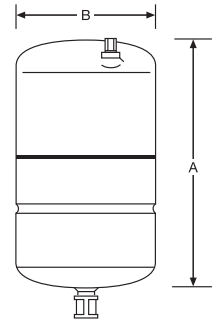

Horizontal (H) and Pump Stand (PS) Models

Model Number	Tank Volume		Max. Acceptance Factor	A Tank Height		B Tank Width		System Connection (NPTM)	Shipping Weight	
	Gal	Lit		In	mm	In	mm		Lbs	Kg
WX-102PS	4.4	17	0.55	12	305	15	381	¾	13	6
WX-110PS	6.7	25	0.40	12	305	20	508	¾	18	8
WX-200PS	14.0	53	0.81	16	406	22	559	1	29	13
WX-202PS	20.0	76	0.57	16	406	30	762	1	35	16
WX-202H	20.0	76	0.57	16	406	30	762	1	33	15

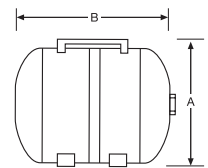

All dimensions and weights are approximate.

Job Name _____	Notes _____
Engineer _____	_____
Contractor _____	_____
P.O. No. _____	_____
Sales Rep. _____	_____
Model No. _____	_____





WELL-X-TROL®

Diaphragm Well Tanks: WX-200PA and WX-300PA Series with PRO ACCESS®

150 PSIG Working Pressure

Construction

Shell	High Strength Steel
Diaphragm	Heavy Duty Butyl
Liner	Antimicrobial
System Connection	Stainless Steel NPTF
Finish	Tuf-Kote™ HG Blue
Water Circulator	Turbulator®
Air Valve	Projection Welded
Factory Precharge	38 PSIG (2.6 bar)

Application

- Controls pump cycling in residential well water systems.
- Can be installed indoors or outdoors.
- PRO ACCESS provides piped to stand convenience for faster installation.

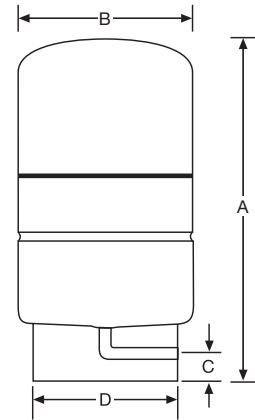

Performance

Maximum Operating Temperature	200°F (93°C)
Maximum Working Pressure	150 PSIG (10.3 bar)
Maximum Relief Valve Setting	125 PSIG (8.6 bar)
Warranty	7-Years

Stand Models

Model Number	Tank Volume		Max. Accept. Factor	A Tank Height		B Tank Diameter		C Sys. Conn. Centerline		D Stand Diameter		System Conn. (NPTF)	Shipping Weight	
	Gal	Lit		In	mm	In	mm	In	mm	In	mm		Lbs	Kg
WX-202PA	20.0	76	0.57	32	813	15	381	1 ⁹ / ₃₂	40	12	304	1	33	15
WX-202XLPA	26.0	98	0.44	39	991	15	381	1 ⁹ / ₃₂	40	12	304	1	40	18
WX-203PA	32.0	121	0.35	47	1194	15	381	1 ⁹ / ₃₂	40	12	304	1	48	22
WX-205PA	34.0	129	1.00	30	762	22	559	1 ⁵ / ₁₆	49	12	304	1 ¹ / ₄	59	27
WX-250PA	44.0	167	0.77	36	914	22	559	1 ⁵ / ₁₆	49	20 ¹ / ₂	521	1 ¹ / ₄	67	30
WX-251PA	62.0	235	0.55	47	1194	22	559	1 ⁵ / ₁₆	49	20 ¹ / ₂	521	1 ¹ / ₄	88	40
WX-255PA	81.0	306	0.41	57	1448	22	559	1 ⁵ / ₁₆	49	20 ¹ / ₂	521	1 ¹ / ₄	111	50
WX-302PA	86.0	326	0.54	47	1194	26	660	2 ¹ / ₁₆	52	20 ¹ / ₂	521	1 ¹ / ₄	108	49
WX-350PA	119.0	450	0.39	62	1575	26	660	2 ¹ / ₁₆	52	20 ¹ / ₂	521	1 ¹ / ₄	148	67

Available in Tan and Gray. Use suffix T or G.

All dimensions and weights are approximate.

Job Name _____	Notes _____
Engineer _____	_____
Contractor _____	_____
P.O. No. _____	_____
Sales Rep. _____	_____
Model No. _____	_____





CHAMPION®

Diaphragm Well Tanks: CH Series

125 PSIG Working Pressure

Construction

Shell	Deep Drawn Steel
Diaphragm	Butyl
Liner	Polypropylene
System Connection	304L Stainless Steel
Finish	Dark Blue
Water Circulator	Turbulator®
Air Valve	Projection Welded
Factory Precharge	38 PSIG (2.6 bar)

Application

- Controls pump cycling in residential well water systems.

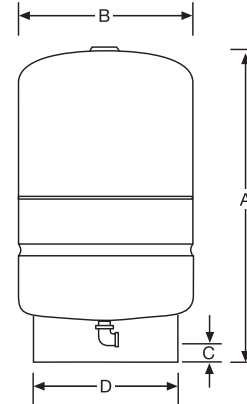

Performance

Maximum Operating Temperature	200°F (93°C)
Maximum Working Pressure	125 PSIG (8.6 bar)
Maximum Relief Valve Setting	100 PSIG (6.9 bar)
Warranty	5-Years

Stand Models

Model	Tank Volume		Max. Accept. Factor	A Tank Height		B Tank Diameter		C Sys. Conn. Centerline		D Stand Diameter		System Conn. (NPTF)	Shipping Weight	
	Gal	Lit		In	mm	In	mm	In	mm	In	mm		Lbs	Kg
CH-14	14.0	53	0.81	25	635	15	381	1 ⁹ / ₃₂	40	12	304	1	24	11
CH-20	20.0	76	0.57	32	813	15	381	1 ⁹ / ₃₂	40	12	304	1	30	14
CH-26	26.0	98	0.44	39	991	15	381	1 ⁹ / ₃₂	40	12	304	1	37	17
CH-32	32.0	121	0.35	47	1194	15	381	1 ⁹ / ₃₂	40	12	304	1	43	20
CH-34	34.0	129	1.00	30	762	22	559	1 ⁵ / ₁₆	49	20 ¹ / ₂	521	1 ¹ / ₄	50	23
CH-44	44.0	167	0.77	36	914	22	559	1 ⁵ / ₁₆	49	20 ¹ / ₂	521	1 ¹ / ₄	57	26
CH-62	62.0	235	0.55	47	1194	22	559	1 ⁵ / ₁₆	49	20 ¹ / ₂	521	1 ¹ / ₄	75	34
CH-81	81.0	301	0.41	57	1448	22	559	1 ⁵ / ₁₆	49	20 ¹ / ₂	521	1 ¹ / ₄	92	42
CH-86	86.0	326	0.54	47	1194	26	660	2 ¹ / ₁₆	52	20 ¹ / ₂	521	1 ¹ / ₄	99	45
CH-119	119.0	450	0.39	62	1575	26	660	2 ¹ / ₁₆	52	20 ¹ / ₂	521	1 ¹ / ₄	133	60

All dimensions and weights are approximate.

Job Name _____	Notes _____
Engineer _____	_____
Contractor _____	_____
P.O. No. _____	_____
Sales Rep. _____	_____
Model No. _____	_____





Construction

Shell	Deep Drawn Steel
Diaphragm	Butyl
Liner	Polypropylene
System Connection	304L Stainless Steel
Finish	Light Gray
Water Circulator	Turbulator®
Air Valve	Projection Welded
Factory Precharge	38 PSIG (2.6 bar)

Application

- Controls pump cycling in residential well water systems.

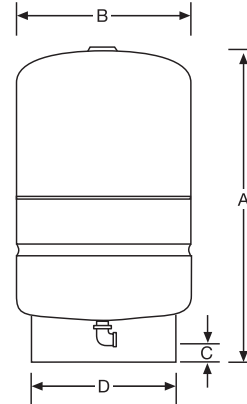

Performance

Maximum Operating Temperature	200°F (93°C)
Maximum Working Pressure	125 PSIG (8.6 bar)
Maximum Relief Valve Setting	100 PSIG (6.9 bar)
Warranty	5-Years

Stand Models

Model	Tank Volume		Max. Accept. Factor	A Tank Height		B Tank Diameter		C Sys. Conn. Centerline		D Stand Diameter		System Conn. (NPTF)	Shipping Weight	
	Gal	Lit		In	mm	In	mm	In	mm	In	mm		In	Lbs
WF-14	14.0	53	0.81	25	635	15	381	1 ⁹ / ₃₂	40	12	304	1	24	11
WF-20	20.0	76	0.57	32	813	15	381	1 ⁹ / ₃₂	40	12	304	1	30	14
WF-26	26.0	98	0.44	39	991	15	381	1 ⁹ / ₃₂	40	12	304	1	37	17
WF-32	32.0	121	0.35	47	1194	15	381	1 ⁹ / ₃₂	40	12	304	1	43	20
WF-34	34.0	129	1.00	30	762	22	559	1 ⁵ / ₁₆	49	20 ¹ / ₂	521	1 ¹ / ₄	50	23
WF-44	44.0	167	0.77	36	914	22	559	1 ⁵ / ₁₆	49	20 ¹ / ₂	521	1 ¹ / ₄	57	26
WF-62	62.0	235	0.55	47	1194	22	559	1 ⁵ / ₁₆	49	20 ¹ / ₂	521	1 ¹ / ₄	75	34
WF-81	81.0	301	0.41	57	1448	22	559	1 ⁵ / ₁₆	49	20 ¹ / ₂	521	1 ¹ / ₄	92	42
WF-86	86.0	326	0.54	47	1194	26	660	2 ¹ / ₁₆	52	20 ¹ / ₂	521	1 ¹ / ₄	99	45
WF-119	119.0	450	0.39	62	1575	26	660	2 ¹ / ₁₆	52	20 ¹ / ₂	521	1 ¹ / ₄	133	60

All dimensions and weights are approximate.

Job Name _____	Notes _____
Engineer _____	_____
Contractor _____	_____
P.O. No. _____	_____
Sales Rep. _____	_____
Model No. _____	_____





PRO-LINE®

Diaphragm Well Tanks: PL Series

125 PSIG Working Pressure

Construction

Shell	Deep Drawn Steel
Diaphragm	Butyl
Liner	Polypropylene
System Connection	304L Stainless Steel
Finish	Tan
Water Circulator	Turbulator®
Air Valve	Projection Welded
Factory Precharge	38 PSIG (2.6 bar)

Application

- Controls pump cycling in residential well water systems.

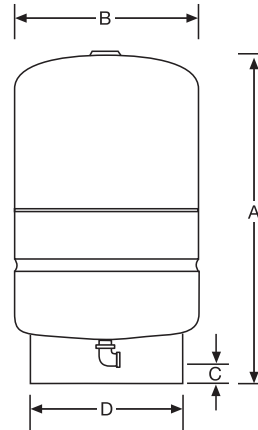

Performance

Maximum Operating Temperature	200°F (93°C)
Maximum Working Pressure	125 PSIG (8.6 bar)
Maximum Relief Valve Setting	100 PSIG (6.9 bar)
Warranty	5-Years

Stand Models

Model	Tank Volume		Max. Accept. Factor	A Tank Height		B Tank Diameter		C Sys. Conn. Centerline		D Stand Diameter		System Conn. (NPTF)	Shipping Weight	
	Gal	Lit		In	mm	In	mm	In	mm	In	mm		Lbs	Kg
PL-14	14.0	53	0.81	25	635	15	381	1 ⁹ / ₃₂	40	12	304	1	24	11
PL-20	20.0	76	0.57	32	813	15	381	1 ⁹ / ₃₂	40	12	304	1	30	14
PL-26	26.0	98	0.44	39	991	15	381	1 ⁹ / ₃₂	40	12	304	1	37	17
PL-32	32.0	121	0.35	47	1194	15	381	1 ⁹ / ₃₂	40	12	304	1	43	20
PL-34	34.0	129	1.00	30	762	22	559	1 ⁵ / ₁₆	49	20 ¹ / ₂	521	1 ¹ / ₄	50	23
PL-44	44.0	167	0.77	36	914	22	559	1 ⁵ / ₁₆	49	20 ¹ / ₂	521	1 ¹ / ₄	57	26
PL-62	62.0	235	0.55	47	1194	22	559	1 ⁵ / ₁₆	49	20 ¹ / ₂	521	1 ¹ / ₄	75	34
PL-81	81.0	301	0.41	57	1448	22	559	1 ⁵ / ₁₆	49	20 ¹ / ₂	521	1 ¹ / ₄	92	42
PL-86	86.0	326	0.54	47	1194	26	660	2 ¹ / ₁₆	52	20 ¹ / ₂	521	1 ¹ / ₄	99	45
PL-119	119.0	450	0.39	62	1575	26	660	2 ¹ / ₁₆	52	20 ¹ / ₂	521	1 ¹ / ₄	133	60

All dimensions and weights are approximate.

Job Name _____	Notes _____
Engineer _____	_____
Contractor _____	_____
P.O. No. _____	_____
Sales Rep. _____	_____
Model No. _____	_____





WELL-X-TROL®

Diaphragm Well Tanks: WX-100C-DD and WX-400C Series ASME

125 PSIG Working Pressure

Construction

Shell	ASME Approved Steel
Diaphragm	Heavy Duty Buty
Liner	Antimicrobial Polypropylene w/ Anti-Legionella Protection
System Connection	Stainless Steel (NPTM) WX-101C-DD through WX-103C-DD Malleable Iron (NPTF) WX-401C through WX-407C
Finish	Red Oxide Primer
Water Circulator	Turbulator®
Air Valve	Schrader Valve w/EPDM Seat
Factory Precharge	25 PSIG (1.7 bar)

Performance

Maximum Operating Temperature	200°F (93°C)
Maximum Working Pressure	125 PSIG (8.6 bar)
Warranty	3-Years

Application

- For use in commercial well water and booster pump systems.
- Fixed diaphragm construction.
- Designed and constructed per ASME Code Section VIII, Division 1.
- Tested to JIS Z 2801 for reduction of Legionella, Staphylococcus and E. coli.
- Follows ASHRAE 188 Anti-Legionella guidelines.
- Sight glass and seismic restraint options available.

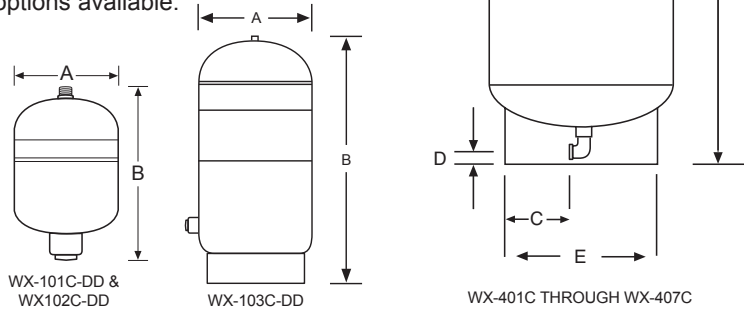

ASME Models

Model Number	Tank Volume		Max. Accept. Volume		A Tank Height		B Tank Diameter		C Sys. Conn. Inset		D Sys. Conn. Centerline		E Stand Diameter		System Conn.	Shipping Weight	
	Gal	Lit	Gal	Lit	In	mm	In	mm	In	mm	In	mm	In	mm	In	Lbs	Kg
WX-101C-DD	2.0	8	.9	3.5	14	356	8	203	-	-	-	-	-	-	¾ NPTM	10	5
WX-102C-DD	6.4	24	3.2	12	18	457	12	305	-	-	-	-	-	-	¾ NPTM	26	12
WX-103C-DD	8.6	33	3.2	12	22	559	12	305	-	-	-	-	10¾	273	¾ NPTM	36	16
WX-401C	18	68	11	42	31	787	16	406	5	124	1½	38	12¾	324	1 NPTF	77	35
WX-402C	25	95	11	42	40	1016	16	406	5	124	1½	38	12¾	324	1 NPTF	93	42
WX-403C	34	129	11	42	49	1245	16	406	5	124	1½	38	12¾	324	1 NPTF	115	52
WX-404C	68	258	34	129	48	1219	24	610	6	159	1⅝	41	16	406	1¼ NPTF	227	103
WX-405C	90	341	34	129	59	1499	24	610	6	159	1⅝	41	16	406	1¼ NPTF	252	114
WX-406C	110	417	34	129	70	1778	24	610	6	159	1⅝	41	16	406	1¼ NPTF	286	130
WX-407C	132	500	46	175	57	1448	30	762	10	254	1¾	44	24	610	1¼ NPTF	436	198

All dimensions and weights are approximate.

Job Name _____	Notes _____
Engineer _____	_____
Contractor _____	_____
P.O. No. _____	_____
Sales Rep. _____	_____
Model No. _____	_____





WELL-X-TROL®

Diaphragm Well Tanks: WX-100C-DD and WX-400C Series ASME

150 PSIG Working Pressure

Construction

Shell	ASME Approved Steel
Diaphragm	Heavy Duty Buty
Liner	Antimicrobial Polypropylene w/ Anti-Legionella Protection
System Connection	Stainless Steel (NPTM) WX-101C-DD through WX-103C-DD Malleable Iron (NPTF) WX-401C through WX-407C
Finish	Red Oxide Primer
Water Circulator	Turbulator®
Air Valve	Schrader Valve w/EPDM Seat
Factory Precharge	25 PSIG (1.7 bar)

Performance

Maximum Operating Temperature	200°F (93°C)
Maximum Working Pressure	150 PSIG (10.3 bar)
Warranty	3-Years

Application

- For use in commercial well water and booster pump systems.
- Fixed diaphragm construction.
- Designed and constructed per ASME Code Section VIII, Division 1.
- Tested to JIS Z 2801 for reduction of Legionella, Staphylococcus and E. coli.
- Follows ASHRAE 188 Anti-Legionella guidelines.
- Sight glass and seismic restraint options available.

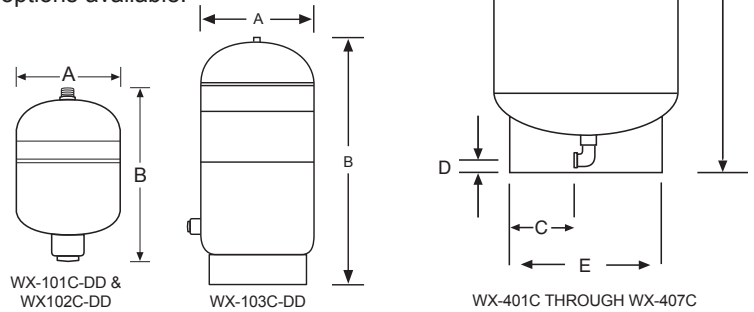

ASME Models

Model Number	Tank Volume		Max. Accept. Volume		A Tank Height		B Tank Diameter		C Sys. Conn. Inset		D Sys. Conn. Centerline		E Stand Diameter		System Conn.	Shipping Weight	
	Gal.	Lit.	Gal.	Lit.	In	mm	In	mm	In	mm	In	mm	In	mm	In	Lbs	Kg
WX-101C-DD	2.0	8	.9	3.5	14	356	8	203	-	-	-	-	-	-	¾ NPTM	10	5
WX-102C-DD	6.4	24	3.2	12	18	457	12	305	-	-	-	-	-	-	¾ NPTM	26	12
WX-103C-DD	8.6	33	3.2	12	22	559	12	305	-	-	-	-	10¾	273	¾ NPTM	36	16
WX-401C	18	68	11	42	31	787	16	406	5	124	1½	38	12¾	324	1 NPTF	96	44
WX-402C	25	95	11	42	40	1016	16	406	5	124	1½	38	12¾	324	1 NPTF	113	51
WX-403C	34	129	11	42	49	1245	16	406	5	124	1½	38	12¾	324	1 NPTF	120	54
WX-404C	68	258	34	129	48	1219	24	610	6	159	1⅝	41	16	406	1¼ NPTF	232	105
WX-405C	90	341	34	129	59	1499	24	610	6	159	1⅝	41	16	406	1¼ NPTF	255	116
WX-406C	110	417	34	129	70	1778	24	610	6	159	1⅝	41	16	406	1¼ NPTF	335	152
WX-407C	132	500	46	175	57	1448	30	762	10	254	1¾	44	24	610	1¼ NPTF	450	204

All dimensions and weights are approximate.

Job Name _____	Notes _____
Engineer _____	_____
Contractor _____	_____
P.O. No. _____	_____
Sales Rep. _____	_____
Model No. _____	_____





WELL-X-TROL®

Diaphragm Well Tanks: WX-100C-DD and WX-400C Series ASME

175 PSIG Working Pressure

Construction

Shell	ASME Approved Steel
Diaphragm	Heavy Duty Buty
Liner	Antimicrobial Polypropylene w/ Anti-Legionella Protection
System Connection	Stainless Steel (NPTM) WX-101C-DD through WX-103C-DD Malleable Iron (NPTF) WX-401C through WX-407C
Finish	Red Oxide Primer
Water Circulator	Turbulator®
Air Valve	Schrader Valve w/EPDM Seat
Factory Precharge	25 PSIG (1.7 bar)

Performance

Maximum Operating Temperature	200°F (93°C)
Maximum Working Pressure	175 PSIG (12.0 bar)
Warranty	3-Years

Application

- For use in commercial well water and booster pump systems.
- Fixed diaphragm construction.
- Designed and constructed per ASME Code Section VIII, Division 1.
- Tested to JIS Z 2801 for reduction of Legionella, Staphylococcus and E. coli.
- Follows ASHRAE 188 Anti-Legionella guidelines.
- Sight glass and seismic restraint options available.

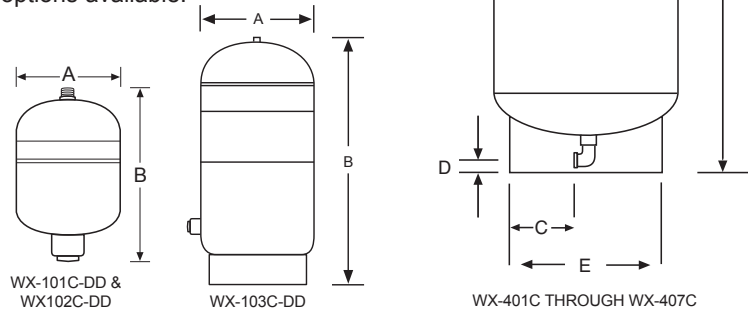

ASME Models

Model Number	Tank Volume		Max. Accept. Volume		A Tank Height		B Tank Diameter		C Sys. Conn. Inset		D Sys. Conn. Centerline		E Stand Diameter		System Conn.	Shipping Weight	
	Gal.	Lit.	Gal.	Lit.	In	mm	In	mm	In	mm	In	mm	In	mm	In	Lbs	Kg
WX-101C-DD	2.0	8	.9	3.5	14	356	8	203	-	-	-	-	-	-	¾ NPTM	10	5
WX-102C-DD	6.4	24	3.2	12	18	457	12	305	-	-	-	-	-	-	¾ NPTM	26	12
WX-103C-DD	8.6	33	3.2	12	22	559	12	305	-	-	-	-	10¾	273	¾ NPTM	36	16
WX-401C	18	68	11	42	31	787	16	406	5	124	1½	38	12¾	324	1 NPTF	110	50
WX-402C	25	95	11	42	40	1016	16	406	5	124	1½	38	12¾	324	1 NPTF	125	57
WX-403C	34	129	11	42	49	1245	16	406	5	124	1½	38	12¾	324	1 NPTF	145	66
WX-404C	68	258	34	129	48	1219	24	610	6	159	1¾	41	16	406	1¼ NPTF	313	142
WX-405C	90	341	34	129	59	1499	24	610	6	159	1¾	41	16	406	1¼ NPTF	384	174
WX-406C	110	417	34	129	70	1778	24	610	6	159	1¾	41	16	406	1¼ NPTF	402	182
WX-407C	132	500	46	175	57	1448	30	762	10	254	1¾	44	24	610	1¼ NPTF	510	231

Job Name _____	Notes _____
Engineer _____	_____
Contractor _____	_____
P.O. No. _____	_____
Sales Rep. _____	_____
Model No. _____	_____





WELL-X-TROL®

Diaphragm Well Tanks: WX-400C Series ASME

250 PSIG Working Pressure

Construction

Shell	ASME Approved Steel
Diaphragm	Heavy Duty Butyl
Liner	Antimicrobial Polypropylene w/ Anti-Legionella Protection
System Connection	Malleable Iron (NPTF)
Finish	Red Oxide Primer
Water Circulator	Turbulator®
Air Valve	Schrader Valve w/EPDM Seat
Factory Precharge	25 PSIG (1.7 bar)

Performance

Maximum Operating Temperature	200°F (93°C)
Maximum Working Pressure	250 PSIG (17.2 bar)
Warranty	3-Years

Application

- For use in commercial well water and booster pump systems.
- Fixed diaphragm construction.
- Designed and constructed per ASME Code Section VIII, Division 1.
- Tested to JIS Z 2801 for reduction of Legionella, Staphylococcus and E. coli.
- Follows ASHRAE 188 Anti-Legionella guidelines.
- Sight glass and seismic restraint options available.

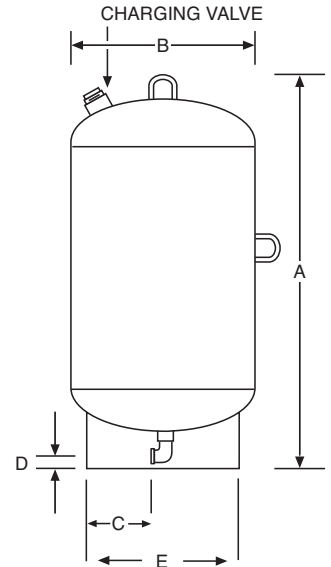

WX-401C THROUGH WX-407C

ASME Models

Model Number	Tank Volume		Max. Accept. Volume		A Tank Height		B Tank Diameter		C Sys. Conn. Inset		D Sys. Conn. Centerline		E Stand Diameter		System Conn. (NPTF)	Shipping Weight	
	Gal.	Lit.	Gal.	Lit.	In.	mm	In.	mm	In.	mm	In.	mm	In.	mm		Lbs	Kg
WX-401C	18	68	11	42	31	787	16	406	5	124	1½	38	12¾	324	1	126	57
WX-402C	25	95	11	42	40	1016	16	406	5	124	1½	38	12¾	324	1	145	65
WX-403C	34	129	11	42	49	1245	16	406	5	124	1½	38	12¾	324	1	183	83
WX-404C	68	258	34	129	48	1219	24	610	6	159	1⅝	41	16	406	1¼	411	186
WX-405C	90	341	34	129	59	1499	24	610	6	159	1⅝	41	16	406	1¼	433	196
WX-406C	110	417	34	129	70	1778	24	610	6	159	1⅝	41	16	406	1¼	475	215
WX-407C	132	500	46	175	57	1448	30	762	10	254	1¾	44	24	610	1¼	570	259

All dimensions and weights are approximate.

Job Name _____	Notes _____
Engineer _____	_____
Contractor _____	_____
P.O. No. _____	_____
Sales Rep. _____	_____
Model No. _____	_____



Certified to NSF/ANSI CAN 61





WELL-X-TROL®

Diaphragm Well Tanks: WX-400C Series ASME

300 PSIG Working Pressure

Construction

Shell	ASME Approved Steel
Diaphragm	Heavy Duty Butyl
Liner	Antimicrobial Polypropylene w/ Anti-Legionella Protection
System Connection	Malleable Iron (NPTF)
Finish	Red Oxide Primer
Water Circulator	Turbulator®
Air Valve	Schrader Valve w/EPDM Seat
Factory Precharge	25 PSIG (1.7 bar)

Performance

Maximum Operating Temperature	200°F (93°C)
Maximum Working Pressure	300 PSIG (20.7 bar)
Warranty	3-Years

Application

- For use in commercial well water and booster pump systems.
- Fixed diaphragm construction.
- Designed and constructed per ASME Code Section VIII, Division 1.
- Tested to JIS Z 2801 for reduction of Legionella, Staphylococcus and E. coli.
- Follows ASHRAE 188 Anti-Legionella guidelines.
- Sight glass and seismic restraint options available.

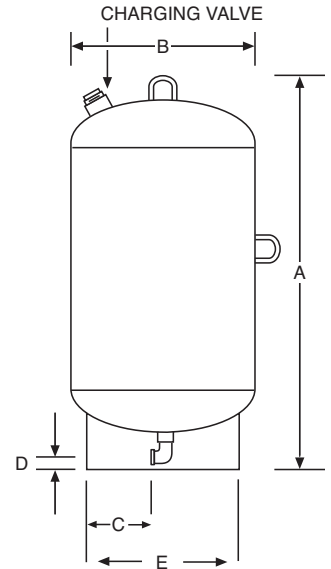

ASME Models

Model Number	Tank Volume		Max. Accept. Volume		A Tank Height		B Tank Diameter		C Sys. Conn. Inset		D Sys. Conn. Centerline		E Stand Diameter		System Conn. (NPTF)	Shipping Weight	
	Gal	Lit	Gal	Lit	In	mm	In	mm	In	mm	In	mm	In	mm		Lbs	Kg
WX-401C	18	68	11	42	31	787	16	406	5	124	1½	38	12¾	324	1	133	60
WX-402C	25	95	11	42	40	1016	16	406	5	124	1½	38	12¾	324	1	160	73
WX-403C	34	129	11	42	49	1245	16	406	5	124	1½	38	12¾	324	1	200	91
WX-404C	68	258	34	129	48	1219	24	610	6	159	1⅝	41	16	406	1¼	432	196
WX-405C	90	341	34	129	59	1499	24	610	6	159	1⅝	41	16	406	1¼	460	209
WX-406C	110	417	34	129	70	1778	24	610	6	159	1⅝	41	16	406	1¼	500	227
WX-407C	132	500	46	175	57	1448	30	762	10	254	1¾	44	24	610	1¼	625	284

All dimensions and weights are approximate.

Job Name _____	Notes _____
Engineer _____	_____
Contractor _____	_____
P.O. No. _____	_____
Sales Rep. _____	_____
Model No. _____	_____



Certified to NSF/ANSI CAN 61





WELL-X-TROL®

Full Acceptance Bladder Well Tanks: WX-440C – WX-460C Series ASME

125 PSIG Working Pressure

Construction

Shell	ASME Approved Steel
Full Acceptance Bladder	Heavy Duty Butyl
Bladder Thickness	.100 In. Minimum
System Connection	Malleable Iron (NPTF)
Finish	Red Oxide Primer
Air Valve	Schrader Valve w/EPDM Seats
Factory Precharge	25 PSIG (1.7 bar)

Performance

Maximum Operating Temperature	240°F (115°C)
Maximum Working Pressure	125 PSIG (8.6 bar)
Warranty	3-Years

Application

- For use in commercial well water and booster pump systems.
- Replaceable bladder design.
- Designed and constructed per ASME Code Section VIII, Division 1.
- Sight glass and seismic restraint options available.
- Available with S/S system connection.

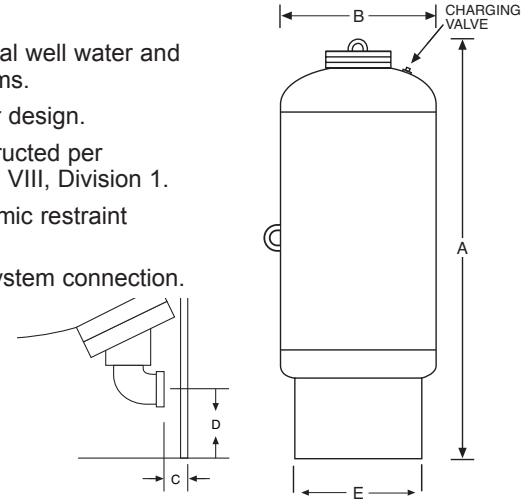

ASME Models

Model Number	Tank Volume		Max. Accept. Volume		A Tank Height		B Tank Diameter		C Sys. Conn. Inset		D Sys. Conn. Centerline		E Stand Diameter		System Conn. (NPTF)	Shipping Weight	
	Gal	Lit	Gal	Lit	In	mm	In	mm	In	mm	In	mm	In	mm		Lbs	Kg
WX-447C	53	200	53	200	45	1143	24	610	2	51	3¾	95	19	483	2	263	119
WX-448C	80	300	80	300	59	1498	24	610	2	51	3¾	95	19	483	2	315	143
WX-449C	106	400	106	400	73	1854	24	610	2	51	3¾	95	19	483	2	319	145
WX-450C	132	500	132	500	87	2210	24	610	2	51	3¾	95	19	483	2	351	159
WX-451C	158	600	158	600	73	1854	30	762	3½	89	5½	140	24	610	2	493	224
WX-452C	211	800	211	800	91	2311	30	762	3½	89	5½	140	24	610	2	602	273
WX-453C	264	1000	264	1000	86	2184	36	914	3⅞	98	6¾	171	30	762	3	676	307
WX-454C	317	1200	317	1200	98	2489	36	914	3⅞	98	6¾	171	30	762	3	762	346
WX-455C	370	1400	370	1400	110	2794	36	914	3⅞	98	6¾	171	30	762	3	843	382
WX-456C	422	1600	422	1600	82	2083	48	1219	7½	191	7⅞	181	42	1067	3	1154	523
WX-457C	528	2000	528	2000	97	2464	48	1219	7½	191	7⅞	181	42	1067	3	1331	604
WX-458C	660	2500	660	2500	84	2134	60	1524	7⅞	194	7⅞	181	54	1372	4	1450	658
WX-459C	792	3000	792	3000	99	2515	60	1524	7⅞	194	7⅞	181	54	1372	4	2169	984
WX-460C	925	3500	925	3500	107	2718	60	1524	7⅞	194	7⅞	181	54	1372	4	2300	1043
WX-461C	1056	4000	1056	4000	121	3073	60	1524	7⅞	194	7⅞	181	54	1372	4	2638	1197
WX-462C	1320	5000	1320	5000	104	2642	72	1829	8⅞	213	4¾	121	60	1524	4	3500	1588
WX-463C	1980	7500	1980	7500	140	3556	72	1829	8	203	6	152	60	1524	4	4100	1860

All dimensions and weights are approximate.

Job Name _____	Notes _____
Engineer _____	_____
Contractor _____	_____
P.O. No. _____	_____
Sales Rep. _____	_____
Model No. _____	_____





WELL-X-TROL®

Full Acceptance Bladder Well Tanks: WX-440C – WX-460C Series ASME

150 PSIG Working Pressure

Construction

Shell	ASME Approved Steel
Full Acceptance Bladder	Heavy Duty Butyl
Bladder Thickness	.100 In. Minimum
System Connection	Malleable Iron (NPTF)
Finish	Red Oxide Primer
Air Valve	Schrader Valve w/EPDM Seats
Factory Precharge	25 PSIG (1.7 bar)

Performance

Maximum Operating Temperature	240°F (115°C)
Maximum Working Pressure	150 PSIG (10.3 bar)
Warranty	3-Years

Application

- For use in commercial well water and booster pump systems.
- Replaceable bladder design.
- Designed and constructed per ASME Code Section VIII, Division 1.
- Sight glass and seismic restraint options available.
- Available with S/S system connection.

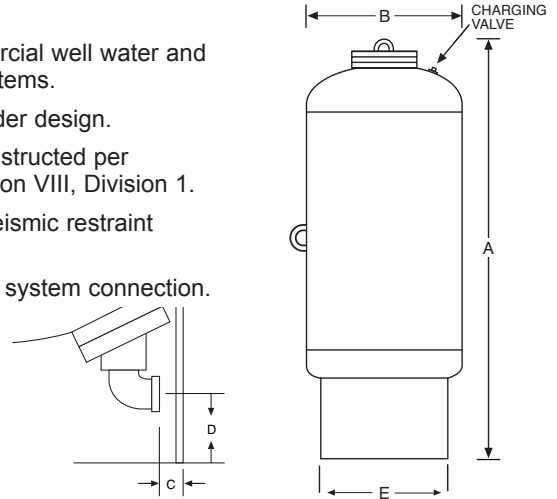

ASME Models

Model Number	Tank Volume		Max. Accept. Volume		A Tank Height		B Tank Diameter		C Sys. Conn. Inset		D Sys. Conn. Centerline		E Stand Diameter		System Conn. (NPTF)	Shipping Weight	
	Gal	Lit	Gal	Lit	In	mm	In	mm	In	mm	In	mm	In	mm		In	Lbs
WX-447C	53	200	53	200	45	1143	24	610	2	51	3¾	95	19	483	2	289	131
WX-448C	80	300	80	300	59	1498	24	610	2	51	3¾	95	19	483	2	338	153
WX-449C	106	400	106	400	73	1854	24	610	2	51	3¾	95	19	483	2	350	159
WX-450C	132	500	132	500	87	2210	24	610	2	51	3¾	95	19	483	2	392	178
WX-451C	158	600	158	600	73	1854	30	762	3½	89	5½	140	24	610	2	587	266
WX-452C	211	800	211	800	91	2311	30	762	3½	89	5½	140	24	610	2	627	284
WX-453C	264	1000	264	1000	86	2184	36	914	3⅞	98	6¾	171	30	762	3	752	341
WX-454C	317	1200	317	1200	98	2489	36	914	3⅞	98	6¾	171	30	762	3	840	381
WX-455C	370	1400	370	1400	110	2794	36	914	3⅞	98	6¾	171	30	762	3	930	422
WX-456C	422	1600	422	1600	82	2083	48	1219	7½	191	7½	181	42	1067	3	1418	643
WX-457C	528	2000	528	2000	97	2464	48	1219	7½	191	7½	181	42	1067	3	1500	680
WX-458C	660	2500	660	2500	84	2134	60	1524	7⅝	194	7⅝	181	54	1372	4	1740	789
WX-459C	792	3000	792	3000	99	2515	60	1524	7⅝	194	7⅝	181	54	1372	4	2385	1082
WX-460C	925	3500	925	3500	107	2718	60	1524	7⅝	194	7⅝	181	54	1372	4	2530	1148
WX-461C	1056	4000	1056	4000	121	3073	60	1524	7⅝	194	7⅝	181	54	1372	4	2900	1315
WX-462C	1320	5000	1320	5000	104	2642	72	1829	8⅝	213	4¾	121	60	1372	4	3850	1746
WX-463C	1980	7500	1980	7500	140	3556	72	1829	8	203	6	152	60	1372	4	4510	2046

All dimensions and weights are approximate.

Job Name _____	Notes _____
Engineer _____	_____
Contractor _____	_____
P.O. No. _____	_____
Sales Rep. _____	_____
Model No. _____	_____





WELL-X-TROL®

Full Acceptance Bladder Well Tanks: WX-440C — WX-460C Series ASME

175 PSIG Working Pressure

Construction

Shell	ASME Approved Steel
Full Acceptance Bladder	Heavy Duty Butyl
Bladder Thickness	.100 In. Minimum
System Connection	Malleable Iron (NPTF)
Finish	Red Oxide Primer
Air Valve	Schrader Valve w/EPDM Seats
Factory Precharge	25 PSIG (1.7 bar)

Performance

Maximum Operating Temperature	240°F (115°C)
Maximum Working Pressure	175 PSIG (12 bar)
Warranty	3-Years

Application

- For use in commercial well water and booster pump systems.
- Replaceable bladder design.
- Designed and constructed per ASME Code Section VIII, Division 1.
- Sight glass and seismic restraint options available.
- Available with S/S system connection.

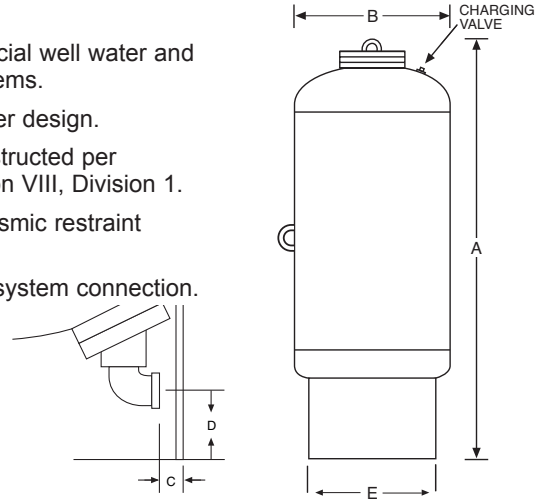

ASME Models

Model Number	Tank Volume		Max. Accept. Volume		A Tank Height		B Tank Diameter		C Sys. Conn. Inset		D Sys. Conn. Centerline		E Stand Diameter		System Conn. (NPTF)	Shipping Weight	
	Gal	Lit	Gal	Lit	In	mm	In	mm	In	mm	In	mm	In	mm		Lbs	Kg
WX-447C	53	200	53	200	45	1143	24	610	2	51	3¼	95	19	483	2	368	167
WX-448C	80	300	80	300	59	1498	24	610	2	51	3¼	95	19	483	2	430	195
WX-449C	106	400	106	400	73	1854	24	610	2	51	3¼	95	19	483	2	440	200
WX-450C	132	500	132	500	87	2210	24	610	2	51	3¼	95	19	483	2	454	206
WX-451C	158	600	158	600	73	1854	30	762	3½	89	5½	140	24	610	2	680	308
WX-452C	211	800	211	800	91	2311	30	762	3½	89	5½	140	24	610	2	694	315
WX-453C	264	1000	264	1000	86	2184	36	914	3⅝	98	6¾	171	30	762	3	846	384
WX-454C	317	1200	317	1200	98	2489	36	914	3⅝	98	6¾	171	30	762	3	959	435
WX-455C	370	1400	370	1400	110	2794	36	914	3⅝	98	6¾	171	30	762	3	1060	481
WX-456C	422	1600	422	1600	82	2083	48	1219	7½	191	7⅝	181	42	1067	3	1655	751
WX-457C	528	2000	528	2000	97	2464	48	1219	7½	191	7⅝	181	42	1067	3	1870	848
WX-458C	660	2500	660	2500	84	2134	60	1524	7⅝	194	7⅝	181	54	1372	4	2030	921
WX-459C	792	3000	792	3000	99	2515	60	1524	7⅝	194	7⅝	181	54	1372	4	3036	1377
WX-460C	925	3500	925	3500	107	2718	60	1524	7⅝	194	7⅝	181	54	1372	4	3220	1461
WX-461C	1056	4000	1056	4000	121	3073	60	1524	7⅝	194	7⅝	181	54	1372	4	3695	1676
WX-462C	1320	5000	1320	5000	104	2642	72	1829	8⅝	213	4¾	121	60	1372	4	4900	2223
WX-463C	1980	7500	1980	7500	140	3556	72	1829	8	203	6	152	60	1372	4	5740	2604

All dimensions and weights are approximate.

Job Name _____	Notes _____
Engineer _____	_____
Contractor _____	_____
P.O. No. _____	_____
Sales Rep. _____	_____
Model No. _____	_____





WELL-X-TROL®

Full Acceptance Bladder Well Tanks: WX-440C – WX-460C Series ASME

250 PSIG Working Pressure

Construction

Shell	ASME Approved Steel
Full Acceptance Bladder	Heavy Duty Butyl
Bladder Thickness	.100 In. Minimum
Finish	Red Oxide Primer
Air Valve	Schrader Valve w/EPDM Seats
Factory Precharge	25 PSIG (1.7 bar)

Performance

Maximum Operating Temperature	240°F (115°C)
Maximum Working Pressure	250 PSIG (17.2 bar)
Warranty	3-Years

Application

- For use in commercial well water and booster pump systems.
- Replaceable bladder design.
- Designed and constructed per ASME Code Section VIII, Division 1.
- Sight glass and seismic restraint options available
- Available with S/S system connection.

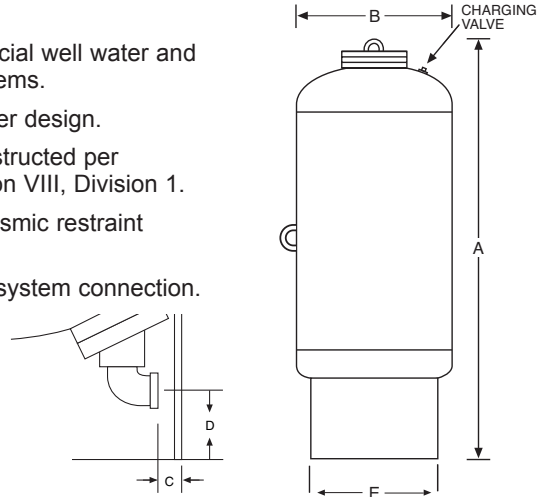

ASME Models

Model Number	Tank Volume		Max. Accept. Factor		A Tank Height		B Tank Diameter		C Sys. Conn. Inset		D Conn. Centerline		E Stand Diameter		System Conn. (NPTF)	Shipping Weight	
	Gal	Lit	Gal	Lit	In	mm	In	mm	In	mm	In	mm	In	mm		Lbs	Kg
WX-447C	53	200	53	200	45	1143	24	610	2	51	3¼	95	19	483	2	420	191
WX-448C	80	300	80	300	59	1498	24	610	2	51	3¼	95	19	483	2	492	223
WX-449C	106	400	106	400	73	1854	24	610	2	51	3¼	95	19	483	2	507	230
WX-450C	132	500	132	500	87	2210	24	610	2	51	3¼	95	19	483	2	570	259
WX-451C	158	600	158	600	73	1854	30	762	3½	89	5½	140	24	610	2	813	369
WX-452C	211	800	211	800	91	2311	30	762	3½	89	5½	140	24	610	2	1007	457
WX-453C	264	1000	264	1000	86	2184	36	914	3⅝	98	6¼	171	30	762	3	1095	497
WX-454C	317	1200	317	1200	98	2489	36	914	3⅝	98	6¼	171	30	762	3	1264	573
WX-455C	370	1400	370	1400	110	2794	36	914	3⅝	98	6¼	171	30	762	3	1350	612
WX-456C	422	1600	422	1600	82	2083	48	1219	7½	191	7⅝	181	42	1067	3	1700	771
WX-457C	528	2000	528	2000	97	2464	48	1219	7½	191	7⅝	181	42	1067	3	2231	1012
WX-458C	660	2500	660	2500	84	2134	60	1524	7⅝	194	7⅝	181	54	1372	4	2320	1052
WX-459C	792	3000	792	3000	99	2515	60	1524	7⅝	194	7⅝	181	54	1372	4	3470	1574
WX-460C	925	3500	925	3500	107	2718	60	1524	7⅝	194	7⅝	181	54	1372	4	3680	1669
WX-461C	1056	4000	1056	4000	121	3073	60	1524	7⅝	194	7⅝	181	54	1372	4	4220	1914
WX-462C	1320	5000	1320	5000	104	2642	72	1829	8⅝	213	4¾	121	60	1372	4	5600	2540
WX-463C	1980	7500	1980	7500	140	3556	72	1829	8	203	6	152	60	1372	4	6560	2976

All dimensions and weights are approximate.

Job Name _____	Notes _____
Engineer _____	_____
Contractor _____	_____
P.O. No. _____	_____
Sales Rep. _____	_____
Model No. _____	_____





WELL-X-TROL®

Full Acceptance Bladder Well Tanks: WX-440C — WX-460C Series ASME

300 PSIG Working Pressure

Construction

Shell	ASME Approved Steel
Full Acceptance Bladder	Heavy Duty Butyl
Bladder Thickness	.100 In. Minimum
Finish	Red Oxide Primer
Air Valve	Schrader Valve w/EPDM Seats
Factory Precharge	25 PSIG (1.7 bar)

Performance

Maximum Operating Temperature	240°F (115°C)
Maximum Working Pressure	300 PSIG (21 bar)
Warranty	3-Years

Application

- For use in commercial well water and booster pump systems.
- Replaceable bladder design.
- Designed and constructed per ASME Code Section VIII, Division 1.
- Sight glass and seismic restraint options available.
- Available with S/S system connection.

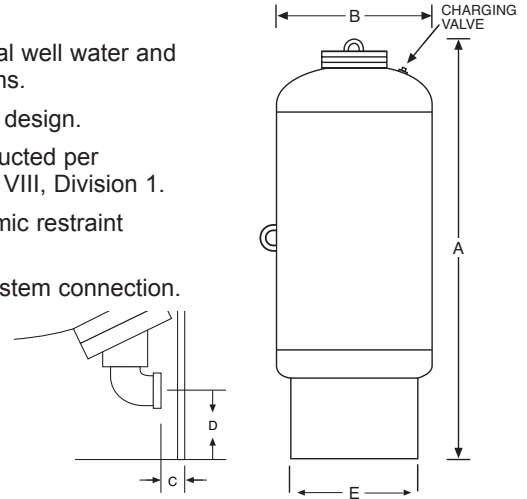

ASME Models

Model Number	Tank Volume		Max. Accept. Volume		A Tank Height		B Tank Diameter		C Sys. Conn. Inset		D Sys. Conn. Centerline		E Stand Diameter		System Conn. (NPTF)	Shipping Weight	
	Gal	Lit	Gal	Lit	In	mm	In	mm	In	mm	In	mm	In	mm		Lbs	Kg
WX-447C	53	200	53	200	45	1143	24	610	2	51	3 ³ / ₄	95	19	483	2	462	210
WX-448C	80	300	80	300	59	1498	24	610	2	51	3 ³ / ₄	95	19	483	2	540	245
WX-449C	106	400	106	400	73	1854	24	610	2	51	3 ³ / ₄	95	19	483	2	557	253
WX-450C	132	500	132	500	87	2210	24	610	2	51	3 ³ / ₄	95	19	483	2	627	284
WX-451C	158	600	158	600	73	1854	30	762	3 ¹ / ₂	89	5 ¹ / ₂	140	24	610	2	894	406
WX-452C	211	800	211	800	91	2311	30	762	3 ¹ / ₂	89	5 ¹ / ₂	140	24	610	2	1107	502
WX-453C	264	1000	264	1000	86	2184	36	914	3 ⁵ / ₈	98	6 ³ / ₄	171	30	762	3	1204	546
WX-454C	317	1200	317	1200	98	2489	36	914	3 ⁵ / ₈	98	6 ³ / ₄	171	30	762	3	1390	630
WX-455C	370	1400	370	1400	110	2794	36	914	3 ⁵ / ₈	98	6 ³ / ₄	171	30	762	3	1485	674
WX-456C	422	1600	422	1600	82	2083	48	1219	7 ¹ / ₂	191	7 ⁵ / ₈	181	42	1067	3	1826	828
WX-457C	528	2000	528	2000	97	2464	48	1219	7 ¹ / ₂	191	7 ⁵ / ₈	181	42	1067	3	2450	1111
WX-458C	660	2500	660	2500	84	2134	60	1524	7 ⁵ / ₈	194	7 ⁵ / ₈	181	54	1372	4	2750	1247
WX-459C	792	3000	792	3000	99	2515	60	1524	7 ⁵ / ₈	194	7 ⁵ / ₈	181	54	1372	4	3690	1674
WX-460C	925	3500	925	3500	107	2718	60	1524	7 ⁵ / ₈	194	7 ⁵ / ₈	181	54	1372	4	3910	1773
WX-461C	1056	4000	1056	4000	121	3073	60	1524	7 ⁵ / ₈	194	7 ⁵ / ₈	181	54	1372	4	4485	2034
WX-462C	1320	5000	1320	5000	104	2642	72	1829	8 ³ / ₈	213	4 ³ / ₄	121	60	1372	4	5950	2699
WX-463C	1980	7500	1980	7500	140	3556	72	1829	8	203	6	152	60	1372	4	6970	3162

All dimensions and weights are approximate.

Job Name _____	Notes _____
Engineer _____	_____
Contractor _____	_____
P.O. No. _____	_____
Sales Rep. _____	_____
Model No. _____	_____





WELL-X-TROL®

Partial Acceptance Bladder Well Tanks: WX Series ASME

125 PSIG Working Pressure

Construction

Shell	ASME Approved Steel
Bladder Material	Heavy Duty Butyl
Bladder Thickness (models 35-100)	.087 In. Minimum
Bladder Thickness (models 130-600)	.100 In. Minimum
System Connection	Malleable Iron (NPTF)
Finish	Red Oxide Primer
Air Valve	Schrader Valve w/ EPDM Seats
Factory Precharge	25 PSIG (1.7 bar)

Performance

Maximum Operating Temperature	240°F (115°C)
Maximum Working Pressure	125 PSIG (8.6 bar)
Warranty	3-Years

Application

- For use in commercial well water and booster pump systems.
- Replaceable bladder design.
- Sight glass and seismic restraint options available.
- Designed and constructed per ASME Code Section VIII, Division 1..

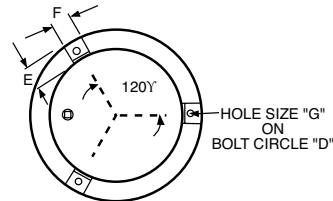

BOTTOM VIEW

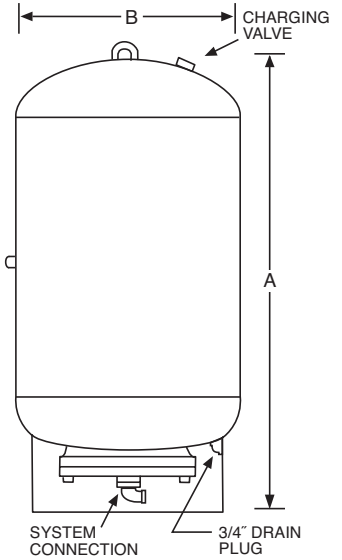

ASME Models

Model Number	Tank Volume		Max. Accept. Volume		A Tank Height		B Tank Diameter		System Conn. (NPTF)	Shipping Weight	
	Gal	Lit	Gal	Lit	In	mm	In	mm		In	Lbs
WX-35CL	10	35	10	35	37	941	10	254	1¼	69	32
WX-50CL	13	50	11	40	37	941	12	305	1¼	76	35
WX-85CL	22	85	11	40	35	889	16	406	1¼	92	42
WX-100CL	26	100	11	40	39	991	16	406	1¼	98	45
WX-130CL	34	130	27	100	35	889	20	508	1½	136	62
WX-165CL	44	165	27	100	40	1016	20	508	1½	146	67
WX-200CL	53	200	27	100	41	1041	24	610	1½	198	91
WX-300CL	80	300	27	100	56	1423	24	610	1½	236	108
WX-400CL	106	400	53	200	69	1743	24	610	2	282	129
WX-500CL	132	500	53	200	83	2108	24	610	2	316	144
WX-600CL	158	600	53	200	67	1702	30	762	2	450	206

All dimensions and weights are approximate.

Optional Seismic Restraints

Tank Diameter	Bolt Circle	Dim.	Dim.	Hole Size
B	D	E	F	G
10	12½	2	2	9/16
12	14¾	2	2	9/16
16	14¾	2	2	9/16
20	14¾	2	2	9/16
24	18	2	2	9/16
30	21½	3	3	¾

Job Name _____	Notes _____
Engineer _____	_____
Contractor _____	_____
P.O. No. _____	_____
Sales Rep. _____	_____
Model No. _____	_____





250 PSIG Working Pressure

Construction

Shell	ASME Approved Steel
Bladder Material	Heavy Duty Butyl/NSF/ANSI 61
Bladder Thickness	.100 Minimum
System Connection	Steel - (ANSI Flange)
Finish	Red Oxide Primer
Air Valve	Schrader Valve w/EPDM Seats
Factory Precharge	25 PSIG (1.7 bar)

Performance

Maximum Operating Temperature	200°F (93°C)
Maximum Working Pressure	250 PSIG (17.2 bar)
Warranty	3-Years

Application

- For use in domestic water surge and/or water hammer applications.
- Designed and constructed per ASME Code Section VIII, Division 1.

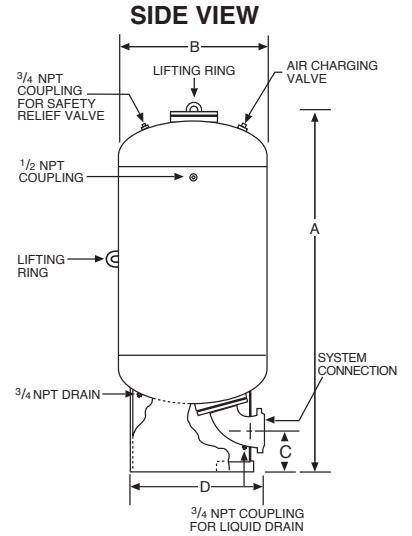

ASME Models

Model Number	Tank Volume		Max. Accept. Factor	A Tank Height		B Tank Diameter		Sys. Conn.		C Conn. Centerline		D Stand Diameter		Shipping Weight	
	Gal	Lit		In	mm	In	mm	In	mm	In	mm	In	mm	Lbs	Kg
D-7	53	200	1.0	49	1245	24	610	4	102	8 ³ / ₁₆	208	19	483	390	177
D-11	80	300	1.0	63	1600	24	610	4	102	8 ³ / ₁₆	208	19	483	505	229
D-14	106	400	1.0	77	1956	24	610	4	102	8 ³ / ₁₆	208	19	483	618	280
D-18	132	500	1.0	91	2311	24	610	4	102	8 ³ / ₁₆	208	19	483	731	332
D-21	158	600	1.0	75	1905	30	762	4	102	7 ¹ / ₄	184	24	610	950	431
D-28	211	800	1.0	93	2362	30	762	4	102	7 ¹ / ₄	184	24	610	1125	510
D-35	264	1000	1.0	85	2159	36	914	6	152	7 ¹ / ₂	191	30	762	1520	689
D-42	317	1200	1.0	97	2464	36	914	6	152	7 ¹ / ₂	191	30	762	1720	780
D-50	370	1400	1.0	110	2794	36	914	6	152	7 ¹ / ₂	191	30	762	1900	862
D-56	422	1600	1.0	86	2184	48	1219	8	203	10 ⁷ / ₈	276	42	1067	2300	1043
D-70	528	2000	1.0	100	2540	48	1219	8	203	10 ⁷ / ₈	276	42	1067	2700	1225

All dimensions and weights are approximate.

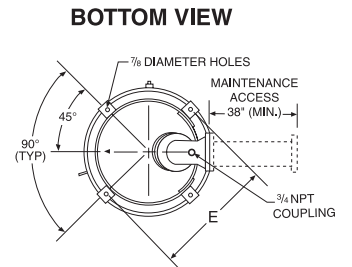

Models D-21 thru D-70

Job Name _____	Notes _____
Engineer _____	_____
Contractor _____	_____
P.O. No. _____	_____
Sales Rep. _____	_____
Model No. _____	_____





THERM-X-TROL®

Thermal Expansion Tanks: ST Series Non-ASME

150 PSIG Working Pressure

Construction

Shell	Glass-Filled Composite
Membrane	Patented air cell
System Connection	Composite w/304L SS Waterway
Finish	Matte Black
Factory Precharge	Sealed; No Adjustment Required

Performance

Maximum Operating Temperature	140°F (60°C)
Maximum Working Pressure	150 PSIG (10.3 bar)
Warranty	7-Year Limited

Application

- Protects Tankless and Point Of Use (P.O.U.) water heaters against thermal expansion and water hammer.
- For use in closed, potable water systems to control pressure build-up.
- Meets Manufacturer and Plumbing Code requirements. Prevents relief valve spillage and protects sensitive heat exchangers.

Model

Model Number	A Tank Diameter		B Tank Height		System Connection (NPTM)	Shipping Weight	
	In	mm	In	mm		Lbs	Kg
ST-1	3.4	86	4.0	102	½	1	0.45

All dimensions and weights are approximate.

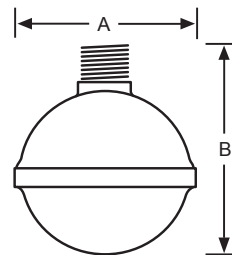

Job Name _____	Notes _____
Engineer _____	_____
Contractor _____	_____
P.O. No. _____	_____
Sales Rep. _____	_____
Model No. _____	_____





THERM-X-TROL®

Thermal Expansion Tanks: Diaphragm ST-C Series ASME

150 PSIG Working Pressure

Construction

Shell	ST-5C through ST-42VC: Deep Drawn Steel ST-60VC through ST-210VC: Steel Head & Shell
Diaphragm	Heavy Duty Butyl NSF/ANSI 61
Liner	Antimicrobial Polypropylene w/Anti-Legionella Protection
System Connection	Stainless Steel
Finish	Red Oxide Primer
Water Circulator	Turbulator® (Deep Drawn Models)
Air Valve	Schrader Valve w/ EPDM Seat
Factory Precharge	55 PSIG (3.8 bar)

Performance

Maximum Operating Temperature	200°F (93°C)
Maximum Working Pressure	150 PSIG (10.3 bar)
Warranty	3-Years

Application

- For use in closed, domestic hot water systems to control pressure buildup.
- Fixed diaphragm construction.
- Designed and constructed per ASME Code Section VIII, Division 1.
- Tested to JIS Z 2801 for reduction of Legionella, Staphylococcus and E. coli.
- Follows ASHRAE 188 Anti-Legionella guidelines.
- All models available with optional sight glass.
- Seismic restraints available on stand models only.
- Deep drawn models are lighter, stronger and more compact than traditional head and shell construction.

Deep Drawn In-Line & Stand Models

Model Number	Tank Volume		Max. Accept. Factor	A Tank Diameter		B Tank Height		System Conn. (NPTM)	Shipping Weight	
	Gal	Lit		In	mm	In	mm		Lbs	Kg
ST-5C-DD	2.0	8	.45	8	203	14	356	3/4	10	5
ST-12C-DD	6.4	24	.50	12	305	18	457	3/4	26	12
ST-20VC-DD	8.6	33	.37	12	305	22	559	3/4	36	16
ST-30VC-DD	16.5	63	.68	15	381	25	636	3/4	48	22
ST-42VC-DD	23.0	88	.49	15	381	33	838	3/4	68	31

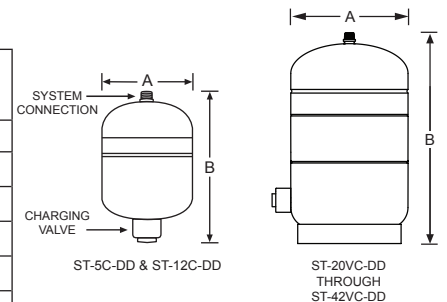

Head & Shell Stand Models

Model Number	Tank Volume		Max. Accept. Factor	A Tank Diameter		B Tank Height		System Conn. (NPTF)	Shipping Weight	
	Gal	Lit		In	mm	In	mm		Lbs	Kg
ST-60VC	25.0	95	.44	16	406	32	813	3/4	85	39
ST-70VC	34.0	129	.32	16	406	45	1143	3/4	99	45
ST-80VC	53.0	201	.66	24	610	37	940	1 1/4	224	102
ST-120VC	68.0	257	.51	24	610	44	1118	1 1/4	266	121
ST-180VC	77.0	291	.45	24	610	49	1245	1 1/4	285	129
ST-210VC	90.0	341	.39	24	610	57	1448	1 1/4	319	145

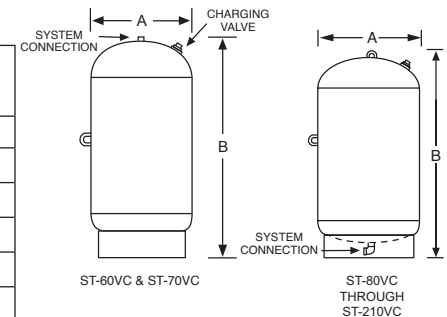

All dimensions and weights are approximate.

Job Name _____	Notes _____
Engineer _____	_____
Contractor _____	_____
P.O. No. _____	_____
Sales Rep. _____	_____
Model No. _____	_____

188
AntiLegionella. Antimicrobial



Certified to NSF/ANSI CAN 61



Turbulator
DEEP DRAWN
MODELS





THERM-X-TROL®

Thermal Expansion Tanks: ST-C Series ASME

175 PSIG Working Pressure

Construction

Shell	ST-5C through ST-42VC: Deep Drawn Steel ST-60VC through ST-210VC: Steel Head & Shell
Diaphragm	Heavy Duty Butyl NSF/ANSI 61
Liner	Antimicrobial Polypropylene w/Anti-Legionella Protection
System Connection	Stainless Steel
Finish	Red Oxide Primer
Water Circulator	Turbulator® (Deep Drawn Models)
Air Valve	Shrader Valve with EPDM Seat
Factory Precharge	55 PSIG (3.8 bar)

Performance

Maximum Operating Temperature	200°F (93°C)
Maximum Working Pressure	175 PSIG (12 bar)
Warranty	3-Years

Application

- For use in closed, domestic hot water systems to control pressure buildup.
- Fixed diaphragm construction.
- Designed and constructed per ASME Code Section VIII, Division 1.
- Tested to JIS Z 2801 for reduction of Legionella, Staphylococcus and E. coli.
- Follows ASHRAE 188 Anti-Legionella guidelines.
- All models available with optional sight glass.
- Seismic restraints available on stand models only.
- Deep drawn models are lighter, stronger and more compact than traditional head and shell construction.

Deep Drawn In-Line & Stand Models

Model Number	Tank Volume		Max. Accept. Factor	A Tank Diameter		B Tank Height		System Connection (NPTM)	Shipping Weight	
	Gal	Lit		In	mm	In	mm		Lbs	Kg
ST-5C-DD	2.0	8	.45	8	203	14	356	3/4	12	5
ST-12C-DD	6.4	24	.50	12	305	18	457	3/4	28	13
ST-20VC-DD	8.6	33	.37	12	305	22	559	3/4	38	17

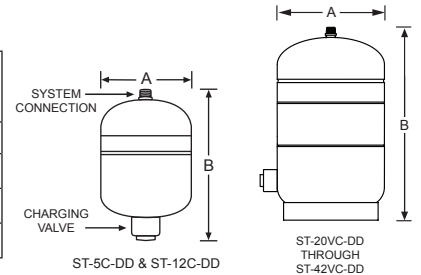

Head & Shell Stand Models

Model Number	Tank Volume		Max. Accept. Factor	A Tank Diameter		B Tank Height		System Connection (NPTF)	Shipping Weight	
	Gal	Lit		In	mm	In	mm		Lbs	Kg
ST-30VC	14.0	53	.64	16	406	19	483	3/4	64	29
ST-42VC	18.0	68	.61	16	406	24	610	3/4	75	34
ST-60VC	25.0	95	.44	16	406	32	813	3/4	113	51
ST-70VC	34.0	129	.32	16	406	45	1143	3/4	122	55
ST-80VC	53.0	201	.66	24	610	37	940	1 1/4	296	134
ST-120VC	68.0	257	.51	24	610	44	1118	1 1/4	340	154
ST-180VC	77.0	291	.45	24	610	49	1245	1 1/4	360	163
ST-210VC	90.0	341	.39	24	610	57	1448	1 1/4	380	172

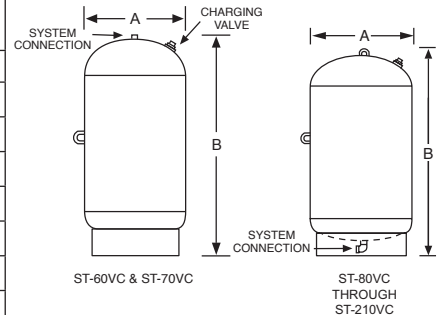

All dimensions and weights are approximate.

Job Name _____	Notes _____
Engineer _____	_____
Contractor _____	_____
P.O. No. _____	_____
Sales Rep. _____	_____
Model No. _____	_____



Certified to NSF/ANSI CAN 61





THERM-X-TROL®

Thermal Expansion Tanks: ST-C Series ASME

250 PSIG Working Pressure

Construction

Shell	Steel
Diaphragm	Heavy Duty Butyl NSF/ANSI 61
Liner	Antimicrobial Polypropylene w/Anti-Legionella Protection
System Connection	Stainless Steel
Finish	Red Oxide Primer
Air Valve	Shrader Valve with EPDM Seat
Factory Precharge	55 PSIG (3.8 bar)

Performance

Maximum Operating Temperature	200°F (93°C)
Maximum Working Pressure	250 PSIG (17.2 bar)
Warranty	3-Years

Application

- For use in closed, potable water systems to control pressure build-up.
- Fixed diaphragm construction.
- Designed and constructed per ASME Code Section VIII, Division 1.
- Tested to JIS Z 2801 for reduction of Legionella, Staphylococcus and E. coli.
- Follows ASHRAE 188 Anti-Legionella guidelines.
- All models available with optional sight glass.
- Seismic restraints available on stand models only.

In-Line Models

Model Number	Tank Volume		Max. Accept. Factor	A Tank Diameter		B Tank Height		System Connection (NPTF)	Shipping Weight	
	Gal	Lit		In	mm	In	mm		In	Lbs
ST-5C	2.1	8	.43	10	254	10	254	3/4	25	11
ST-12C	6.4	24	.50	12	305	14	356	3/4	42	19

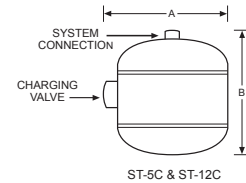

Stand Models

Model Number	Tank Volume		Max. Accept. Factor	A Tank Diameter		B Tank Height		System Connection (NPTF)	Shipping Weight	
	Gal	Lit		In	mm	In	mm		In	Lbs
ST-20VC	8	30	.40	12	305	19	483	3/4	50	23
ST-30VC	14	53	.64	16	406	19	483	3/4	96	44
ST-42VC	18	68	.61	16	406	24	610	3/4	101	46
ST-60VC	25	95	.44	16	406	32	813	3/4	125	57
ST-70VC	34	129	.32	16	406	45	1143	3/4	136	62
ST-80VC	53	201	.66	24	610	37	940	1 1/4	305	138
ST-120VC	68	257	.51	24	610	44	1118	1 1/4	375	170
ST-180VC	77	291	.45	24	610	49	1245	1 1/4	380	172
ST-210VC	90	341	.39	24	610	57	1448	1 1/4	405	184

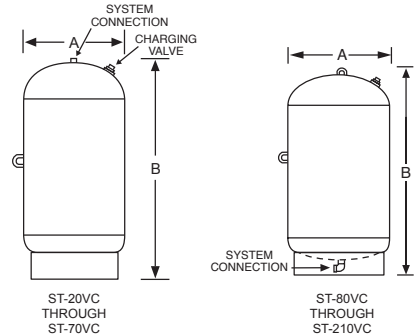

All dimensions and weights are approximate.

Job Name _____	Notes _____
Engineer _____	_____
Contractor _____	_____
P.O. No. _____	_____
Sales Rep. _____	_____
Model No. _____	_____





300 PSIG Working Pressure

Construction

Shell	Steel
Diaphragm	Heavy Duty Butyl NSF/ANSI 61
Liner	Antimicrobial Polypropylene w/Anti-Legionella Protection
System Connection	Stainless Steel
Finish	Red Oxide Primer
Air Valve	Schrader Valve w/ EPDM Seat
Factory Precharge	55 PSIG (3.8 bar)

Performance

Maximum Operating Temperature	200°F (93°C)
Maximum Working Pressure	300 PSIG (20.7 bar)
Warranty	3-Years

Application

- For use in closed, potable water systems to control pressure build-up.
- Fixed diaphragm construction.
- Designed and constructed per ASME Code Section VIII, Division 1.
- Tested to JIS Z 2801 for reduction of Legionella, Staphylococcus and E. coli.
- Follows ASHRAE 188 Anti-Legionella guidelines.
- All models available with optional sight glass.
- Seismic restraints available on stand models only.

In-Line Models

Model Number	Tank Volume		Max. Accept. Factor	A Tank Diameter		B Tank Height		System Connection (NPTF)	Shipping Weight	
	Gal	Lit		In	mm	In	mm		In	Lbs
ST-5C	2.1	8	.45	10	254	10	254	3/4	30	14
ST-12C	6.4	24	.50	12	305	14	356	3/4	50	23

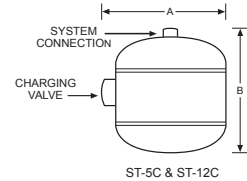

Stand Models

Model Number	Tank Volume		Max. Accept. Factor	A Tank Diameter		B Tank Height		System Connection (NPTF)	Shipping Weight	
	Gal	Lit		In	mm	In	mm		In	Lbs
ST-20VC	8	30	.40	12	305	19	483	3/4	62	28
ST-30VC	14	53	.64	16	406	19	483	3/4	108	49
ST-42VC	18	68	.61	16	406	24	610	3/4	112	51
ST-60VC	25	95	.44	16	406	32	813	3/4	139	63
ST-70VC	34	129	.32	16	406	45	1143	3/4	151	68
ST-80VC	53	201	.66	24	610	37	940	1 1/4	340	154
ST-120VC	68	257	.51	24	610	44	1118	1 1/4	400	181
ST-180VC	77	291	.45	24	610	49	1245	1 1/4	420	191
ST-210VC	90	341	.39	24	610	57	1448	1 1/4	440	200

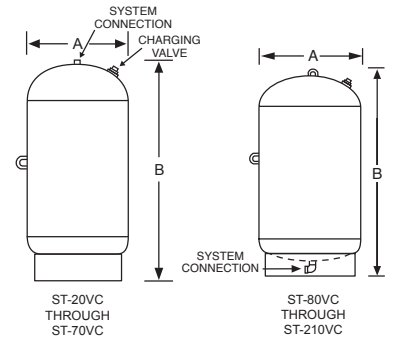

All dimensions and weights are approximate.

Job Name _____	Notes _____
Engineer _____	_____
Contractor _____	_____
P.O. No. _____	_____
Sales Rep. _____	_____
Model No. _____	_____





THERM-X-TROL®

Thermal Expansion: Full Acceptance Bladder ST-440C and ST-450C Series ASME

125 PSIG Working Pressure

Construction

Shell	Steel
Bladder Material	Heavy Duty Butyl NSF/ANSI 61
Bladder Thickness	.100 In Minimum
System Connection	Bronze
Finish	Red Oxide Primer
Air Valve	Schrader Valve w/ EPDM Seat
Factory Precharge	25 PSIG (1.7 bar)

Performance

Maximum Operating Temperature	240°F (115°C)
Maximum Working Pressure	125 PSIG (8.6 bar)
Warranty	3-Years

Application

- For use in closed, potable water systems to control pressure build-up.
- Full acceptance replaceable bladder design.
- Optional sight glass and seismic restraints available.
- Designed and constructed per ASME Code Section VIII, Division 1.

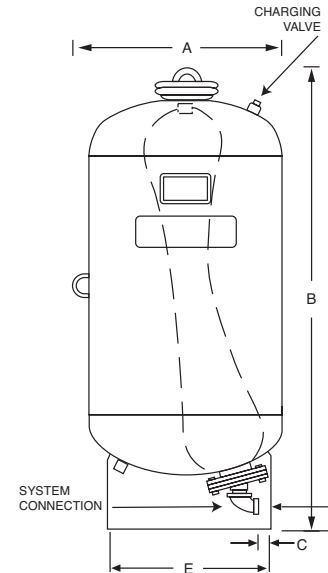

ASME Models

Model Number	Tank Volume		Max. Accept. Factor	A Tank Diameter		B Tank Height		C System Conn. Height		D Conn. Centerline		E Stand Diameter		System Conn. (NPTF)	Shipping Weight	
	Gal	Lit		In	mm	In	mm	In	mm	In	mm	In	mm		Lbs	Kg
ST-447C	53	200	1.0	24	610	45	1143	2	51	3¾	95	19	483	2	236	107
ST-448C	80	300	1.0	24	610	59	1498	2	51	3¾	95	19	483	2	274	124
ST-449C	106	400	1.0	24	610	73	1854	2	51	3¾	95	19	483	2	320	145
ST-450C	132	500	1.0	24	610	87	2210	2	51	3¾	95	19	483	2	354	161
ST-451C	158	600	1.0	30	762	73	1854	3½	89	5½	140	24	610	2	494	224
ST-452C	211	800	1.0	30	762	91	2311	3½	89	5½	140	24	610	2	593	269
ST-453C	264	1000	1.0	36	914	86	2184	4½	114	7	178	30	762	3	667	303
ST-454C	317	1200	1.0	36	914	98	2438	4½	114	7	178	30	762	3	762	346
ST-455C	370	1400	1.0	36	914	110	2794	4½	114	7	178	30	762	3	842	382
ST-456C	422	1600	1.0	48	1219	82	2083	7½	191	7⅛	178	42	1067	3	1152	523
ST-457C	528	2000	1.0	48	1219	97	2464	7½	191	7⅛	178	42	1067	3	1335	606

All dimensions and weights are approximate.

Job Name _____	Notes _____
Engineer _____	_____
Contractor _____	_____
P.O. No. _____	_____
Sales Rep. _____	_____
Model No. _____	_____





THERM-X-TROL®

Thermal Expansion: Full Acceptance Bladder ST-440C and ST-450C Series ASME

150 PSIG Working Pressure

Construction

Shell	Steel
Bladder Material	Heavy Duty Butyl NSF/ANSI 61
Bladder Thickness	.100 In Minimum
System Connection	Bronze
Finish	Red Oxide Primer
Air Valve	Schrader Valve w/ EPDM Seat
Factory Precharge	25 PSIG (1.7 bar)

Performance

Maximum Operating Temperature	240°F (115°C)
Maximum Working Pressure	150 PSIG (10.3 bar)
Warranty	3-Years

Application

- For use in closed, potable water systems to control pressure build-up.
- Full acceptance replaceable bladder design.
- Optional sight glass and seismic restraints available.
- Designed and constructed per ASME Code Section VIII, Division 1.

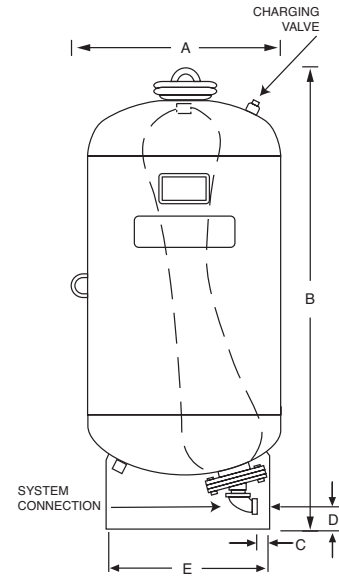

ASME Models

Model Number	Tank Volume		Max. Accept. Factor	A Tank Diameter		B Tank Height		C System Conn. Height		D Conn. Centerline		E Stand Diameter		System Conn. (NPTF)	Shipping Weight	
	Gal	Lit		In	mm	In	mm	In	mm	In	mm	In	mm		Lbs	Kg
ST-447C	53	200	1.0	24	610	45	1143	2	51	3¾	95	19	483	2	262	119
ST-448C	80	300	1.0	24	610	59	1498	2	51	3¾	95	19	483	2	340	154
ST-449C	106	400	1.0	24	610	73	1854	2	51	3¾	95	19	483	2	360	163
ST-450C	132	500	1.0	24	610	87	2210	2	51	3¾	95	19	483	2	400	181
ST-451C	158	600	1.0	30	762	73	1854	3½	89	5½	140	24	610	2	587	266
ST-452C	211	800	1.0	30	762	91	2311	3½	89	5½	140	24	610	2	625	283
ST-453C	264	1000	1.0	36	914	86	2184	4½	114	7	178	30	762	3	760	345
ST-454C	317	1200	1.0	36	914	98	2438	4½	114	7	178	30	762	3	850	386
ST-455C	370	1400	1.0	36	914	110	2794	4½	114	7	178	30	762	3	935	424
ST-456C	422	1600	1.0	48	1219	82	2083	7½	191	7⅞	178	42	1067	3	1423	645
ST-457C	528	2000	1.0	48	1219	97	2464	7½	191	7⅞	178	42	1067	3	1505	683

All dimensions and weights are approximate.

Job Name _____	Notes _____
Engineer _____	_____
Contractor _____	_____
P.O. No. _____	_____
Sales Rep. _____	_____
Model No. _____	_____





THERM-X-TROL®

Thermal Expansion: Full Acceptance Bladder ST-440C and ST-450C Series ASME

175 PSIG Working Pressure

Construction

Shell	Steel
Bladder Material	Heavy Duty Butyl NSF/ANSI 61
Bladder Thickness	.100 In Minimum
System Connection	Bronze
Finish	Red Oxide Primer
Air Valve	Schrader Valve w/ EPDM Seat
Factory Precharge	25 PSIG (1.7 bar)

Performance

Maximum Operating Temperature	240°F (115°C)
Maximum Working Pressure	175 PSIG (12 bar)
Warranty	3-Years

Application

- For use in closed, potable water systems to control pressure build-up.
- Full acceptance replaceable bladder design.
- Optional sight glass and seismic restraints available.
- Designed and constructed per ASME Code Section VIII, Division 1.

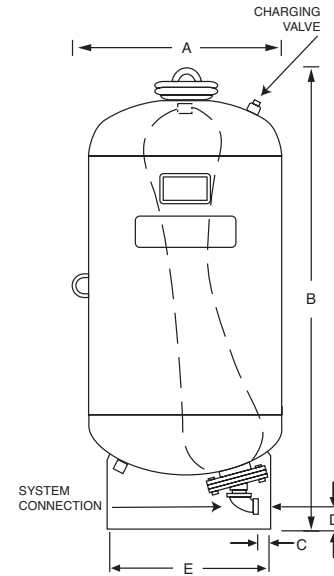

ASME Models

Model Number	Tank Volume		Max. Accept. Factor	A Tank Diameter		B Tank Height		C System Conn. Height		D Conn. Centerline		E Stand Diameter		System Conn. (NPTF)	Shipping Weight	
	Gal	Lit		In	mm	In	mm	In	mm	In	mm	In	mm		Lbs	Kg
ST-447C	53	200	1.0	24	610	45	1143	2	51	3¾	95	19	483	2	290	132
ST-448C	80	300	1.0	24	610	59	1498	2	51	3¾	95	19	483	2	430	195
ST-449C	106	400	1.0	24	610	73	1854	2	51	3¾	95	19	483	2	450	204
ST-450C	132	500	1.0	24	610	87	2210	2	51	3¾	95	19	483	2	460	209
ST-451C	158	600	1.0	30	762	73	1854	3½	89	5½	140	24	610	2	680	308
ST-452C	211	800	1.0	30	762	91	2311	3½	89	5½	140	24	610	2	699	317
ST-453C	264	1000	1.0	36	914	86	2184	4½	114	7	178	30	762	3	845	384
ST-454C	317	1200	1.0	36	914	98	2438	4½	114	7	178	30	762	3	960	435
ST-455C	370	1400	1.0	36	914	110	2794	4½	114	7	178	30	762	3	1065	483
ST-456C	422	1600	1.0	48	1219	82	2083	7½	191	7⅞	178	42	1067	3	1650	748
ST-457C	528	2000	1.0	48	1219	97	2464	7½	191	7⅞	178	42	1067	3	1875	850

All dimensions and weights are approximate.

Job Name _____	Notes _____
Engineer _____	_____
Contractor _____	_____
P.O. No. _____	_____
Sales Rep. _____	_____
Model No. _____	_____





THERM-X-TROL®

Thermal Expansion: Full Acceptance Bladder ST-440C and ST-450C Series ASME

250 PSIG Working Pressure

Construction

Shell	Steel
Bladder Material	Heavy Duty Butyl NSF/ANSI 61
Bladder Thickness	.100 In Minimum
System Connection	Bronze
Finish	Red Oxide Primer
Air Valve	Schrader Valve w/ EPDM Seat
Factory Precharge	25 PSIG (1.7 bar)

Performance

Maximum Operating Temperature	240°F (115°C)
Maximum Working Pressure	250 PSIG (17.2 bar)
Warranty	3-Years

Application

- For use in closed, potable water systems to control pressure build-up.
- Full acceptance replaceable bladder design.
- Optional sight glass and seismic restraints available.
- Designed and constructed per ASME Code Section VIII, Division 1.

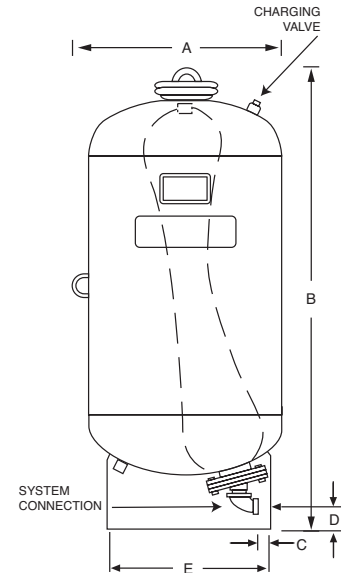

ASME Models

Model Number	Tank Volume		Max. Accept. Factor	A Tank Diameter		B Tank Height		C System Conn. Height		D Conn. Centerline		E Stand Diameter		System Conn. (NPTF)	Shipping Weight	
	Gal	Lit		In	mm	In	mm	In	mm	In	mm	In	mm		Lbs	Kg
ST-447C	53	200	1.0	24	610	45	1143	2	51	3¾	95	19	483	2	370	168
ST-448C	80	300	1.0	24	610	59	1498	2	51	3¾	95	19	483	2	492	223
ST-449C	106	400	1.0	24	610	73	1854	2	51	3¾	95	19	483	2	510	231
ST-450C	132	500	1.0	24	610	87	2210	2	51	3¾	95	19	483	2	570	259
ST-451C	158	600	1.0	30	762	73	1854	3½	89	5½	140	24	610	2	815	370
ST-452C	211	800	1.0	30	762	91	2311	3½	89	5½	140	24	610	2	1005	456
ST-453C	264	1000	1.0	36	914	86	2184	4½	114	7	178	30	762	3	1100	499
ST-454C	317	1200	1.0	36	914	98	2438	4½	114	7	178	30	762	3	1265	574
ST-455C	370	1400	1.0	36	914	110	2794	4½	114	7	178	30	762	3	1350	612
ST-456C	422	1600	1.0	48	1219	82	2083	7½	191	7⅞	178	42	1067	3	1660	753
ST-457C	528	2000	1.0	48	1219	97	2464	7½	191	7⅞	178	42	1067	3	2230	1012

All dimensions and weights are approximate.

Job Name _____	Notes _____
Engineer _____	_____
Contractor _____	_____
P.O. No. _____	_____
Sales Rep. _____	_____
Model No. _____	_____





THERM-X-TROL®

Thermal Expansion: Full Acceptance Bladder ST-440C and ST-450C Series ASME

300 PSIG Working Pressure

Construction

Shell	Steel
Bladder Material	Heavy Duty Butyl NSF/ANSI 61
Bladder Thickness	.100 In Minimum
System Connection	Bronze
Finish	Red Oxide Primer
Air Valve	Schrader Valve w/ EPDM Seat
Factory Precharge	25 PSIG (1.7 bar)

Performance

Maximum Operating Temperature	240°F (115°C)
Maximum Working Pressure	300 PSIG (20.7 bar)
Warranty	3-Years

Application

- For use in closed, potable water systems to control pressure build-up.
- Full acceptance replaceable bladder design.
- Optional sight glass and seismic restraints available.
- Designed and constructed per ASME Code Section VIII, Division 1.

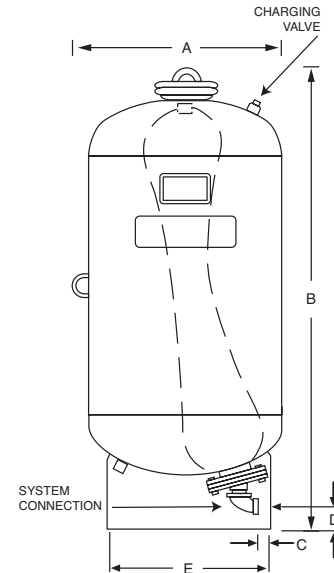

ASME Models

Model Number	Tank Volume		Max. Accept. Factor	A Tank Diameter		B Tank Height		C System Conn. Height		D Conn. Centerline		E Stand Diameter		System Conn. (NPTF)	Shipping Weight	
	Gal	Lit		In	mm	In	mm	In	mm	In	mm	In	mm		In	Lbs
ST-447C	53	200	1.0	24	610	45	1143	2	51	3¾	95	19	483	2	425	193
ST-448C	80	300	1.0	24	610	59	1498	2	51	3¾	95	19	483	2	540	245
ST-449C	106	400	1.0	24	610	73	1854	2	51	3¾	95	19	483	2	560	254
ST-450C	132	500	1.0	24	610	87	2210	2	51	3¾	95	19	483	2	632	287
ST-451C	158	600	1.0	30	762	73	1854	3½	89	5½	140	24	610	2	895	406
ST-452C	211	800	1.0	30	762	91	2311	3½	89	5½	140	24	610	2	1107	502
ST-453C	264	1000	1.0	36	914	86	2184	4½	114	7	178	30	762	3	1205	547
ST-454C	317	1200	1.0	36	914	98	2438	4½	114	7	178	30	762	3	1400	635
ST-455C	370	1400	1.0	36	914	110	2794	4½	114	7	178	30	762	3	1490	676
ST-456C	422	1600	1.0	48	1219	82	2083	7½	191	7⅞	178	42	1067	3	1830	830
ST-457C	528	2000	1.0	48	1219	97	2464	7½	191	7⅞	178	42	1067	3	2455	1114

All dimensions and weights are approximate.

Job Name _____	Notes _____
Engineer _____	_____
Contractor _____	_____
P.O. No. _____	_____
Sales Rep. _____	_____
Model No. _____	_____





THERM-X-TROL®

Thermal Expansion Tanks: Partial Acceptance Bladder ST Series ASME

150 PSIG Working Pressure

Construction

Shell	Carbon Steel
Bladder Material	Heavy Duty Butyl
Bladder Thickness (models 35-100)	.087 In Minimum
Bladder Thickness (models 130-600)	.100 In Minimum
System Connection	Stainless Steel
Finish	Red Oxide Primer
Air Valve	Schrader Valve w/ EPDM Seat
Factory Precharge	25 PSIG (1.7 bar)

Application

- For use in closed, potable water systems to control pressure build-up.
- Partial acceptance replaceable bladder design.
- Optional sight glass and seismic restraints available.
- Designed and constructed per ASME Code Section VIII, Division 1.

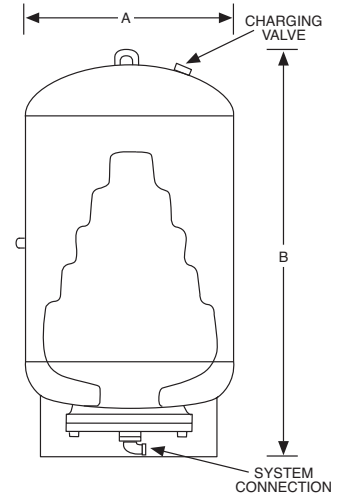

Performance

Maximum Operating Temperature	240°F (115°C)
Maximum Working Pressure	150 PSIG (10.3 bar)
Warranty	3-Years

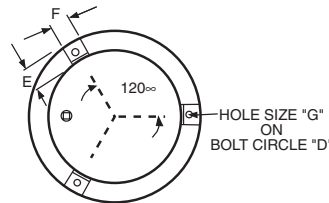

BOTTOM VIEW

ASME Models

Model Number	Tank Volume		Max. Accept. Factor	A Tank Diameter		B Tank Height		System Conn. (NPTF)	Shipping Weight	
	Gal	Lit		In	mm	In	mm		Lbs	Kg
ST-35CL	10	35	1.00	10	254	37	948	1	76	34
ST-50CL	13	50	.85	12	305	37	941	1	78	35
ST-85CL	22	85	.50	16	406	35	872	1	95	43
ST-100CL	26	100	.42	16	406	39	991	1	102	46
ST-130CL	34	130	.79	20	508	35	881	1	134	61
ST-165CL	44	165	.61	20	508	40	1008	1	153	69
ST-200CL	53	200	.51	24	610	41	1039	1	205	93
ST-300CL	80	300	.34	24	610	56	1423	1	254	115
ST-400CL	106	400	.50	24	610	69	1743	1	308	140
ST-500CL	132	500	.40	24	610	83	2096	1	352	160
ST-600CL	158	600	.34	30	762	67	1702	1	442	200

Optional Seismic Restraints

Tank Diameter	Bolt Circle	Dim. E	Dim. F	Hole Size
B	D	E	F	G
10	12 ⁵ / ₈	2	2	⁹ / ₁₆
12	14 ³ / ₄	2	2	⁹ / ₁₆
16	16 ³ / ₄	2	2	⁹ / ₁₆
20	16 ³ / ₄	2	2	⁹ / ₁₆
24	18	2	2	⁹ / ₁₆
30	22 ³ / ₄	3	3	³ / ₄

All dimensions and weights are approximate.

Job Name _____	Notes _____
Engineer _____	_____
Contractor _____	_____
P.O. No. _____	_____
Sales Rep. _____	_____
Model No. _____	_____





THERM-X-TROL®

Thermal Expansion Tanks: ST Series Non-ASME

150 PSIG Working Pressure

Construction

Shell	Steel
Diaphragm	Heavy Duty Butyl NSF/ANSI 61
Liner	Antimicrobial Polypropylene
System Connection	Stainless Steel
Finish	Urethane Topcoat
Water Circulator	Turbulator®
Air Valve	Projection Welded with InSight® Indicator Cap (In-Line Models Only)
Factory Precharge	In-line Models 50 PSIG (3.5 bar) Stand Models 40 PSIG (2.8 bar)

Application

- For use in closed, potable hot water systems to control pressure buildup.
- Accepts expanded water as temperature rises to prevent relief valve discharge and system damage.
- Stand models designed for large residential and light commercial applications.
- Multiple units can be installed to accommodate larger systems.
- In-line models feature patent-pending InSight® Indicator Cap that changes color to indicate tank service.

Performance

Maximum Operating Temperature	200°F (93°C)
Maximum Working Pressure	150 PSIG (10.3 bar)
Warranty	ST-5 through ST-12: 7-Year Limited ST-25V through ST-210V: 1-Year Limited

In-Line Models

Model Number	Tank Volume		Max. Acceptance Factor	A Tank Diameter		B Tank Height		System Connection (NPTM)	Shipping Weight	
	Gal	Lit		In	mm	In	mm		In	Lbs
ST-5	2.0	8	.45	8	203	13	330	¾	5	2.3
ST-12	4.4	17	.73	11	279	15	381	¾	9	4.1

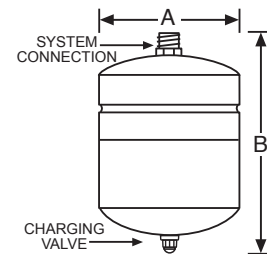

Stand Models

Model Number	Tank Volume		Max. Acceptance Factor	A Tank Diameter		B Tank Height		System Connection (NPTF)	Shipping Weight	
	Gal	Lit		In	mm	In	mm		In	Lbs
ST-25V	10.3	39	1.00	15	381	19	483	¾	23	10
ST-30V	14.0	53	0.81	15	381	24	610	¾	25	11
ST-42V	20.0	76	0.57	15	381	32	813	¾	33	15
ST-60V	34.0	129	1.00	22	559	30	762	1¼	61	28
ST-80V	44.0	167	0.77	22	559	36	914	1¼	69	31
ST-180V	62.0	235	0.55	22	559	47	1194	1¼	92	42
ST-200V	81.0	307	0.44	22	559	56	1422	1¼	103	47
ST-210V	86.0	326	0.54	26	660	47	1194	1¼	123	56

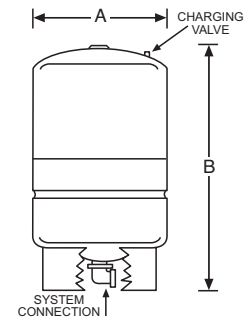

All dimensions and weights are approximate.

Job Name _____	Notes _____
Engineer _____	_____
Contractor _____	_____
P.O. No. _____	_____
Sales Rep. _____	_____
Model No. _____	_____





THERM-X-SPAN®

Thermal Expansion Tanks: T Series Non-ASME

150 PSIG Working Pressure

Construction

Shell	Steel
Diaphragm	Heavy Duty Butyl NSF/ANSI 61
Liner	Polypropylene
Finish	Urethane Topcoat
Air Valve	Projection Welded
Factory Precharge	40 PSIG (2.8 bar)

Application

- For use in closed, potable water systems to control pressure build-up.
- Accepts expanded water as system temperature rises and returns hot water to system when demand occurs.
- Multiple units can be installed to accommodate larger systems.

Performance

Maximum Operating Temperature	200°F (93°C)
Maximum Working Pressure	150 PSIG (10.3 bar)
Warranty	1-Year

In-Line Models

Model Number	Tank Volume		Max. Acceptance Factor	A Tank Diameter		B Tank Height		System Connection (NPTM)	Shipping Weight	
	Gal	Lit		In	mm	In	mm		Lbs	Kg
T-5	2.0	8	.45	8	203	13	330	¾	5	2
T-12	4.4	17	.73	11	279	15	381	¾	9	4

All dimensions and weights are approximate.

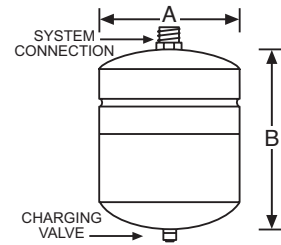

Job Name _____	Notes _____
Engineer _____	_____
Contractor _____	_____
P.O. No. _____	_____
Sales Rep. _____	_____
Model No. _____	_____





COMMERCIAL PREMIER™

Hot Water Makers®

Application

- For use in large residential homes and commercial applications.
- Available with mechanical or electronic controls.

Construction

WH-7		WHS-60, 80, 120	
Description	Standard Construction	Description	Standard Construction
Pressure Shell	Deep Drawn Steel	Pressure Shell	316 L Stainless Steel
Inner Liner	Seamless Polyethylene	Outer Jacket	Polyethylene
Insulation Shell	High Density Urethane	Insulation	CFC-Free Urethane Foam
Heat Exchanger	Finned Copper with Stanoguard Plating	Heat Exchanger	Finned Copper with Stanoguard Plating
Optional Heat Exchanger	Double Wall Tubing	Optional Heat Exchanger	Double Wall Tubing
Temperature Control	Digital: 90-150°F	Temperature Control	Dial Aquastat: 90-180°F

Performance

Model Number	1st Hr Recovery Rating		Continuous Flow Rating		Standby Loss		Boiler Flow Rate Requirements (GPM)	
	Gal	Lit	Gal	Lit	BTU/Hr	°F/Hr	Min	Max
WH-7C	304	1149	268	1013	400	1.2	7	12
WH-7C-DW	304	1149	268	1013	400	1.2	7	12
WHS-60ZC	427	1616	375	1420	200	0.4	7	12
WHS-60ZC-DW	320	1210	268	1013	200	0.4	7	12
WHS-80ZC	445	1685	375	1420	260	0.4	7	12
WHS-80ZC-DW	338	1278	268	1013	260	0.4	7	12
WHS-120ZC	479	1813	375	1420	400	0.4	7	12
WHS-120ZC-DW	372	1406	268	1013	400	0.4	7	12

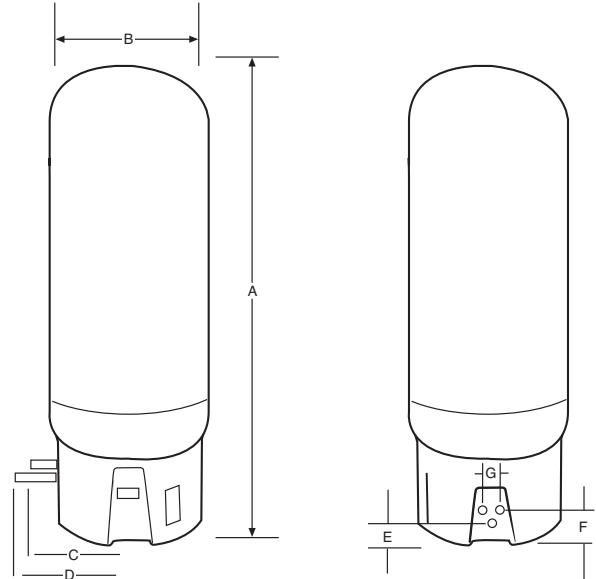

Rough-In Dimensions (Inches)

Dimension	Description	WH-7C	WHS-60	WHS-80	WHS-120
C	Boiler Supply/Return	11	15½	15½	15½
D	Cold Water In	12¼	13	13	14¼
E	Cold Water In	3¾	3¾	3¾	3¾
F	Boiler Supply/Return	6¾	7¼	7¼	7¼
G	Boiler Supply/Return	3¾	3¾	3¾	3¾

Warranty: 5-Years

Models

Model Number	Tank Volume		A Tank Height		B Tank Diameter		Domestic Water Connections		Boiler Water Connections		Shipping Weight	
	Gal	Lit	In	mm	In	mm	Inlet	Outlet	Inlet	Outlet	Lbs	Kg
WH-7C	41	155	48	122	22	56	¾" NPTM	¾" NPTF	¾" NPTM	¾" NPTM	141	64
WH-7C-DW	41	155	48	122	22	56	¾" NPTM	¾" NPTF	1" Sweat Union	1" Sweat Union	151	68
WHS-60ZC	60	227	54	137	26	66	1" NPTM	1" NPTF	1" NPTM	1" NPTM	168	76
WHS-60ZC-DW	60	227	54	137	26	66	1" NPTM	1" NPTF	1" Sweat Union	1" Sweat Union	177	80
WHS-80ZC	80	302	66	168	26	66	1" NPTM	1" NPTF	1" NPTM	1" NPTM	178	81
WHS-80ZC-DW	80	302	66	168	26	66	1" NPTM	1" NPTF	1" Sweat Union	1" Sweat Union	187	85
WHS-120ZC	119	450	71	180	29	74	1" NPTM	1" NPTF	1" NPTM	1" NPTM	218	99
WHS-120ZC-DW	119	450	71	180	29	74	1" NPTM	1" NPTF	1" Sweat Union	1" Sweat Union	227	103

All dimensions and weights are approximate.

Job Name _____	Notes _____
Engineer _____	_____
Contractor _____	_____
P.O. No. _____	_____
Sales Rep. _____	_____
Model No. _____	_____





100 PSIG Working Pressure

Construction

Shell	Steel
Diaphragm	Heavy Duty Butyl/EPDM
System Connection	Welded Steel
Finish	Urethane Topcoat
Air Valve	Projection Welded with InSight® Indicator Cap (2 to 7.4 gal.)
Factory Precharge	12 PSIG (0.8 bar)

Performance

Maximum Operating Temperature	240°F (116°C)
Maximum Working Pressure	100 PSIG (6.9 bar)
Warranty	7-Years

Application

- For use in closed, non-potable, hydronic heating and chilled water systems.
- Accepts expanded water as system temperature rises to reduce pressure build-up.
- Helps reduce energy consumption and system maintenance.
- Fill-Trol® models eliminate the need for a separate automatic fill valve. Tank pressure controls system fill.
- Suitable for propylene glycol applications with mixtures up to 50%.
- 2 through 6.7 gallon models feature patent-pending In-Sight® Indicator Cap that changes color to indicate tank service is required.

EXTROL In-Line Models

Model Number	Tank Volume		Max. Acceptance Factor	A Tank Diameter		B Tank Height		System Connection (NPTM)	Shipping Weight	
	Gal	Lit		In	mm	In	mm		Lbs	Kg
EX-15	2.0	8	.50	8	203	13	330	½	5	2.3
EX-30	4.4	17	.57	11	279	15	406	½	9	4.1
EX-60	6.7	25	.40	11	279	20	508	½	13	5.9
EX-90	14.0	53	.81	15	390	21	533	½	23	10.4

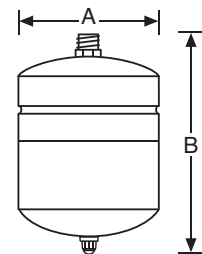

All dimensions and weights are approximate.

FILL-TROL In-Line Models

Model Number	Tank Volume		Max. Acceptance Factor	A Tank Diameter		B Assembled Height		System Connection (NPTF)	Shipping Weight	
	Gal	Lit		In	mm	In	mm		Lbs	Kg
FT-109	2.0	8	.50	8	203	15	381	½	6	2.7
FT-110	4.4	17	.57	11	279	17	432	½	10	4.5
FT-111	6.7	25	.40	11	279	22	558	½	15	6.8
FT-112	14.0	53	.81	15	390	23	584	½	24	10.9

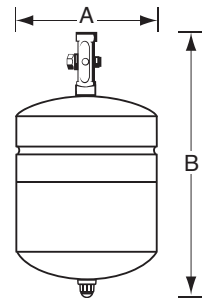

All dimensions and weights are approximate.

Job Name _____	Notes _____
Engineer _____	_____
Contractor _____	_____
P.O. No. _____	_____
Sales Rep. _____	_____
Model No. _____	_____





EXTROL[®] PRO

Hydronic Expansion: EX-PRO Series

125 PSIG Working Pressure

Construction

Shell	Steel
Diaphragm	Heavy Duty Butyl/EPDM
System Connection	Stainless Steel
Liner	Polypropylene Oxygen Barrier
Finish	Urethane Topcoat
Air Valve	Projection Welded with InSight [®] Indicator Cap (2 to 6.7 gal.)
Factory Precharge	15 PSIG (1.03 bar)

Application

- For use in closed, non-potable, hydronic heating and chilled water systems.
- Accepts expanded water as system temperature rises to reduce pressure build-up.
- Helps reduce energy consumption and system maintenance.
- Plastic liner & stainless steel connection protect against corrosion.
- Suitable for propylene glycol applications with mixtures up to 50%.
- 2 through 6.7 gallon models feature patent-pending In-Sight[®] Indicator Cap that changes color to indicate tank service is required.

Performance

Maximum Operating Temperature	200°F (93°C)
Maximum Working Pressure	125 PSIG (6.9 bar)
Warranty	7-Years

EXTROL PRO In-Line Models

Model Number	Tank Volume		Max. Acceptance Factor	A Tank Diameter		B Tank Height		System Connection (NPTM)	Shipping Weight	
	Gal	Lit		In	mm	In	mm		Lbs	Kg
EX-15PRO	2.0	8	.50	8	203	13	330	½	5	2.3
EX-30PRO	4.4	17	.57	11	279	15	406	½	9	4.1
EX-60PRO	6.7	25	.40	11	279	20	508	½	13	5.9

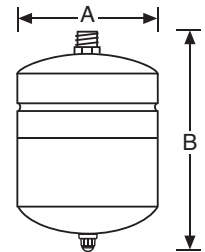

All dimensions and weights are approximate.

Job Name _____	Notes _____
Engineer _____	_____
Contractor _____	_____
P.O. No. _____	_____
Sales Rep. _____	_____
Model No. _____	_____





100 PSIG Working Pressure

Construction

Shell	Steel
Diaphragm	Heavy Duty Butyl/EPDM
System Connection	Steel
Finish	Urethane Topcoat
Air Valve	Projection Welded
Factory Precharge	12 PSIG (.8 bar)

Performance

Maximum Operating Temperature	240°F (115°C)
Maximum Working Pressure	100 PSIG (6.9 bar)
Warranty	1-Year

Application

- For use in large residential and light commercial closed, non-potable, hydronic heating systems.
- Accepts expanded water as system temperature rises to reduce pressure build-up.
- Suitable in propylene glycol applications with mixtures up to 50%.

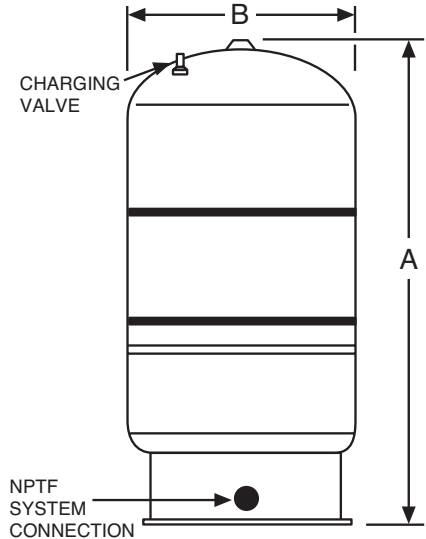
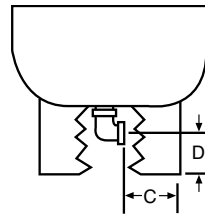

Stand Models

Model Number	Tank Volume		Max. Accept. Factor	A Tank Height		B Tank Diameter		Stand to Connection		System Conn. (NPTF)	Shipping Weight	
	Gal	Lit		In	mm	In	mm	In	mm		Lbs	Kg
SX-30V	14.0	53	.81	25	635	15	390	1 ¹³ / ₁₆	46	1	25	11
SX-40V	20.0	76	.57	33	838	15	390	1 ¹³ / ₁₆	46	1	33	15
SX-60V	32.0	121	.35	48	1219	15	390	1 ¹³ / ₁₆	46	1	43	20
SX-90V	44.0	167	.77	36	914	22	559	2 ³ / ₁₆	56	1 ¹ / ₄	69	31
SX-110V	62.0	235	.55	47	1194	22	559	2 ³ / ₁₆	56	1 ¹ / ₄	92	42
SX-130V	81.0	306	.42	56	1422	22	559	2 ³ / ₁₆	56	1 ¹ / ₄	103	47
SX-160V	86.0	326	.53	47	1194	26	660	2 ³ / ₁₆	56	1 ¹ / ₄	123	56

All dimensions and weights are approximate.

Job Name _____	Notes _____
Engineer _____	_____
Contractor _____	_____
P.O. No. _____	_____
Sales Rep. _____	_____
Model No. _____	_____





125 PSIG Working Pressure

Construction

Shell	ASME Approved Steel
Diaphragm	Heavy Duty Butyl/EPDM
System Connection	NPTF ¹ Malleable Iron Center NPTM ² Steel Pipe, Top Offset
Finish	Red Oxide Primer
Air Valve	Schrader Valve w/EPDM Seats
Factory Precharge	12 PSIG (.8 bar)

Performance

Maximum Operating Temperature	240°F (115°C)
Maximum Working Pressure	125 PSIG (8.6 bar)
Warranty	3-Years

Application

- For use in closed, non-potable hydronic heating and chilled water systems.
- Designed to meet all ASME Code Section VIII, Division 1 standards.
- Available with optional sight glass and seismic restraints (saddles).
- Suitable in propylene glycol applications with mixtures up to 50%.
- Deep drawn models are lighter, stronger and more compact than traditional head and shell construction.

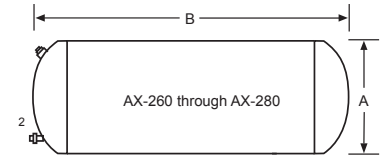
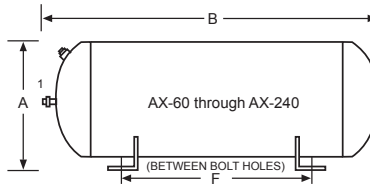
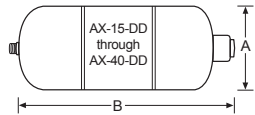
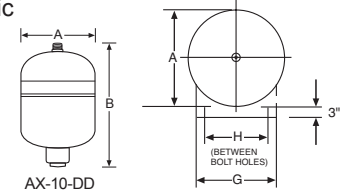

Deep Drawn Horizontal ASME Models

Model Number	Tank Volume		Max. Accept. Volume		A Tank Diameter		B Tank Length		Sys. Conn	Restrains (Saddles) for Horizontal Mounting						Ship Wt. with Restrains (Saddles)		Shipping Weight	
	Gal	Lit	Gal	Lit	In	mm	In	mm		F		G		H		Lbs	Kg	Lbs	Kg
AX-10-DD	6.4	24.2	3.2	12.1	12	305	18	457	3/4 ¹	N/A	N/A	N/A	N/A	N/A	N/A	N/A	N/A	9	4
AX-15-DD	8.6	33.0	3.2	12.1	12	305	22	559	3/4 ¹	N/A	N/A	N/A	N/A	N/A	N/A	N/A	N/A	22	10
AX-20-DD	16.5	63.0	11.3	43.0	15	381	25	636	3/4 ¹	N/A	N/A	N/A	N/A	N/A	N/A	N/A	N/A	44	20
AX-40-DD	23.0	88.0	11.3	43.0	15	381	33	838	3/4 ¹	N/A	N/A	N/A	N/A	N/A	N/A	N/A	N/A	64	29

Head & Shell Horizontal ASME Models

Model Number	Tank Volume		Max. Accept. Volume		A Tank Diameter		B Tank Length		Sys. Conn	Restrains (Saddles) for Horizontal Mounting						Ship Wt. with Restrains (Saddles)		Shipping Weight	
	Gal	Lit	Gal	Lit	In	mm	In	mm		F		G		H		Lbs	Kg	Lbs	Kg
AX-60	33.6	127.2	11.3	42.8	16	356	43	1073	1/2 ¹	36%	918	14	356	12	305	116	53	96	44
AX-80	44.4	168.1	22.6	85.5	24	610	29	725	1 ¹	16%	429	20	508	18	457	173	78	153	69
AX-100	55.7	211.8	22.6	85.5	24	610	33	840	1 ¹	21 1/2%	546	20	508	18	457	194	88	174	79
AX-120	68.0	257.4	34.0	128.7	24	610	41	1051	1 ¹	29 1/2%	749	20	508	18	457	235	107	204	93
AX-144	77.0	291.5	34.0	128.7	24	610	46	1170	1 ¹	34%	873	20	508	18	457	246	112	218	99
AX-180	90.0	340.7	34.0	128.7	24	610	54	1357	1 ¹	41 3/4%	1060	20	508	18	457	248	113	232	105
AX-200	110.0	416.4	34.0	128.7	24	610	64	1624	1 ¹	52 1/4%	1327	20	508	18	457	306	139	269	122
AX-240	132.0	500.0	46.0	174.0	30	762	51	1295	1 ¹	35	889	24	610	22	559	428	194	401	182
AX-260	159.0	600.0	56.0	212.0	30	762	62	1581	1 1/4 ²	44 1/4%	1124	24	610	22	559	480	218	455	206
AX-280	211.0	800.0	84.0	318.0	30	762	80	2032	1 1/4 ²	62	1575	24	610	22	559	660	299	580	263

All dimensions and weights are approximate.

*AX-10 is the only model that can be suspended from the pipes.

Job Name _____	Notes _____
Engineer _____	_____
Contractor _____	_____
P.O. No. _____	_____
Sales Rep. _____	_____
Model No. _____	_____





150 PSIG Working Pressure

Construction

Shell	ASME Approved Steel
Diaphragm	Heavy Duty Butyl/EPDM
System Connection	NPTF ¹ Malleable Iron Center NPTM ² Steel Pipe, Top Offset
Finish	Red Oxide Primer
Air Valve	Schrader Valve w/EPDM Seats
Factory Precharge	12 PSIG (.8 bar)

Performance

Maximum Operating Temperature	240°F (115°C)
Maximum Working Pressure	150 PSIG (10.3 bar)
Warranty	3-Years

Application

- For use in closed, non-potable hydronic heating and chilled water systems.
- Designed to meet all ASME Code Section VIII, Division 1 standards.
- Available with optional sight glass and seismic restraints (saddles).
- Suitable in propylene glycol applications with mixtures up to 50%.
- Deep drawn models are lighter, stronger and more compact than traditional head and shell construction.

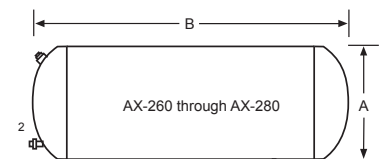
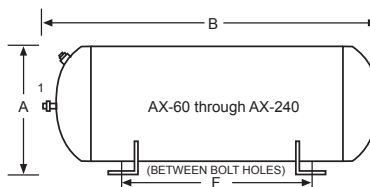
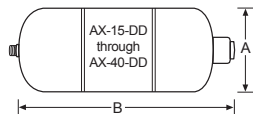
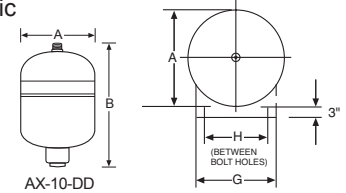

Deep Drawn Horizontal ASME Models

Model Number	Tank Volume		Max. Accept. Volume		A Tank Diameter		B Tank Length		Sys. Conn	Restrains (Saddles) for Horizontal Mounting						Ship Wt. with Restrains (Saddles)		Shipping Weight	
	Gal	Lit	Gal	Lit	In	mm	In	mm		F		G		H		Lbs	Kg	Lbs	Kg
AX-10-DD	6.4	24.2	3.2	12.1	12	305	18	457	3/4" ¹	N/A	N/A	N/A	N/A	N/A	N/A	N/A	N/A	10	5
AX-15-DD	8.6	33.0	3.2	12.1	12	305	22	559	3/4" ¹	N/A	N/A	N/A	N/A	N/A	N/A	N/A	N/A	24	11
AX-20-DD	16.5	63.0	11.3	43.0	15	381	25	636	3/4" ¹	N/A	N/A	N/A	N/A	N/A	N/A	N/A	N/A	46	21
AX-40-DD	23.0	88.0	11.3	43.0	15	381	33	838	3/4" ¹	N/A	N/A	N/A	N/A	N/A	N/A	N/A	N/A	66	30

Head & Shell Horizontal ASME Models

Model Number	Tank Volume		Max. Accept. Volume		A Tank Diameter		B Tank Length		Sys. Conn	Restrains (Saddles) for Horizontal Mounting						Ship Wt. with Restrains (Saddles)		Shipping Weight	
	Gal	Lit	Gal	Lit	In	mm	In	mm		F		G		H		Lbs	Kg	Lbs	Kg
AX-60	33.6	127.2	11.3	42.8	16	356	43	1073	1/2" ¹	36%	918	14	356	12	305	116	53	120	54
AX-80	44.4	168.1	22.6	85.5	24	610	29	725	1"	16%	429	20	508	18	457	173	78	160	73
AX-100	55.7	211.8	22.6	85.5	24	610	33	840	1"	21 1/2%	546	20	508	18	457	194	88	180	32
AX-120	68.0	257.4	34.0	128.7	24	610	41	1051	1"	29 1/2%	749	20	508	18	457	235	107	245	111
AX-144	77.0	291.5	34.0	128.7	24	610	46	1170	1"	34%	873	20	508	18	457	246	112	250	113
AX-180	90.0	340.7	34.0	128.7	24	610	54	1357	1"	41 3/4%	1060	20	508	18	457	248	113	265	120
AX-200	110.0	416.4	34.0	128.7	24	610	64	1624	1"	52 1/4%	1327	20	508	18	457	306	139	320	145
AX-240	132.0	500.0	46.0	174.0	30	762	51	1295	1"	35	889	24	610	22	559	428	194	403	183
AX-260	159.0	600.0	56.0	212.0	30	762	62	1581	1 1/4" ²	44 1/4%	1124	24	610	22	559	480	218	460	209
AX-280	211.0	800.0	84.0	318.0	30	762	80	2032	1 1/4" ²	62	1575	24	610	22	559	660	299	600	272

All dimensions and weights are approximate.

*AX-10 is the only model that can be suspended from the pipes.

Job Name _____	Notes _____
Engineer _____	_____
Contractor _____	_____
P.O. No. _____	_____
Sales Rep. _____	_____
Model No. _____	_____





Construction

Shell	ASME Approved Steel
Diaphragm	Heavy Duty Butyl/EPDM
System Connection	NPTF ¹ Malleable Iron Center NPTM ² Steel Pipe, Top Offset
Finish	Red Oxide Primer
Air Valve	Schrader Valve w/EPDM Seats
Factory Precharge	12 PSIG (.8 bar)

Application

- For use in closed, non-potable hydronic heating and chilled water systems.
- Designed to meet all ASME Code Section VIII, Division 1 standards.
- Available with optional sight glass and seismic restraints (saddles).
- Suitable in propylene glycol applications with mixtures up to 50%.

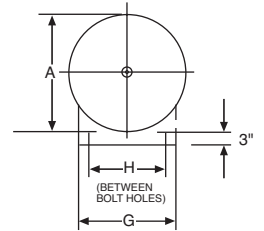

Performance

Maximum Operating Temperature	240°F (115°C)
Maximum Working Pressure	175 PSIG (12 bar)
Warranty	3-Years

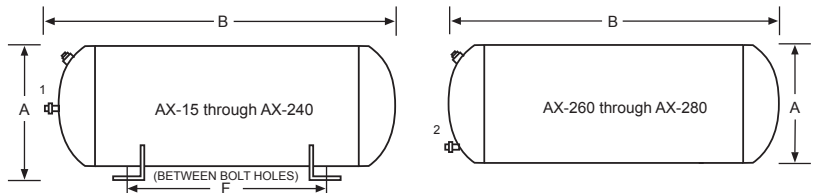

Horizontal ASME Models

Model Number	Tank Volume		Max. Accept. Volume		A Tank Diameter		B Tank Length		Sys. Conn	Restrains (Saddles) for Horizontal Mounting						Ship Wt. with Restrains (Saddles)		Shipping Weight	
	Gal	Lit	Gal	Lit	In	mm	In	mm		F		G		H		Lbs	Kg	Lbs	Kg
AX-15	8.0	30.3	2.4	9.1	12	305	19	489	1/2"	14 3/8	365	10	254	8	203	54	24	48	22
AX-20	10.9	41.3	2.4	9.1	12	305	26	607	1/2"	21 1/8	537	10	254	8	203	66	30	60	27
AX-40	21.7	82.2	11.3	42.8	16	356	29	737	1/2"	22	557	14	356	12	305	112	51	96	44
AX-60	33.6	127.2	11.3	42.8	16	356	43	1073	1/2"	36 3/8	918	14	356	12	305	141	64	125	57
AX-80	44.4	168.1	22.6	85.5	24	610	29	725	1"	16 3/8	429	20	508	18	457	220	100	200	91
AX-100	55.7	211.8	22.6	85.5	24	610	33	840	1"	21 1/2	546	20	508	18	457	247	112	227	103
AX-120	68.0	257.4	34.0	128.7	24	610	41	1051	1"	29 1/2	749	20	508	18	457	286	130	266	121
AX-144	77.0	291.5	34.0	128.7	24	610	46	1170	1"	34 3/8	873	20	508	18	457	305	138	285	129
AX-180	90.0	340.7	34.0	128.7	24	610	54	1357	1"	41 3/4	1060	20	508	18	457	321	146	301	137
AX-200	110.0	416.4	34.0	128.7	24	610	64	1624	1"	52 1/4	1327	20	508	18	457	370	168	350	159
AX-240	132.0	500.0	46.0	174.0	30	762	51	1295	1"	35	889	24	610	22	559	547	248	522	237
AX-260	159.0	600.0	56.0	212.0	30	762	62	1581	1 1/2"	44 1/4	1124	24	610	22	559	597	271	572	269
AX-280	211.0	800.0	84.0	318.0	30	762	80	2032	1 1/2"	62	1575	24	610	22	559	780	354	755	342

All dimensions and weights are approximate.

Job Name _____	Notes _____
Engineer _____	_____
Contractor _____	_____
P.O. No. _____	_____
Sales Rep. _____	_____
Model No. _____	_____





250 PSIG Working Pressure

Construction

Shell	ASME Approved Steel
Diaphragm	Heavy Duty Butyl/EPDM
System Connection	NPTF ¹ Malleable Iron Center NPTM ² Steel Pipe, Top Offset
Finish	Red Oxide Primer
Air Valve	Schrader Valve w/EPDM Seats
Factory Precharge	12 PSIG (.8 bar)

Performance

Maximum Operating Temperature	240°F (115°C)
Maximum Working Pressure	250 PSIG (20.7 bar)
Warranty	3-Years

Application

- For use in closed, non-potable hydronic heating and chilled water systems.
- Designed to meet all ASME Code Section VIII, Division 1 standards.
- Available with optional sight glass and seismic restraints (saddles).
- Suitable in propylene glycol applications with mixtures up to 50%.

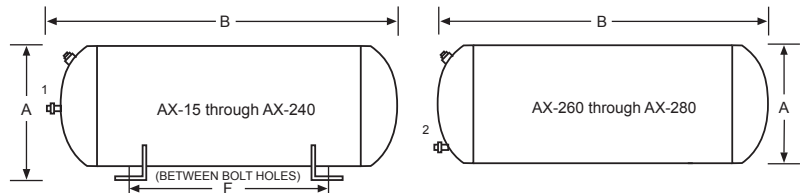
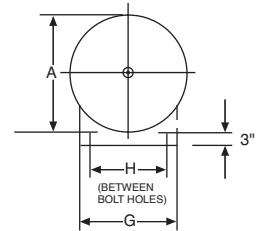

Horizontal ASME Models

Model Number	Tank Volume		Max. Accept. Volume		A Tank Diameter		B Tank Length		Sys. Conn	Restraints (Saddles) for Horizontal Mounting						Ship Wt. with Restraints (Saddles)		Shipping Weight	
										F		G		H					
	Gal	Lit	Gal	Lit	In	mm	In	mm		In	mm	In	mm	In	mm	Lbs	Kg	Lbs	Kg
AX-15	8.0	30.3	2.4	9.1	12	305	19	489	1/2 ¹	14 3/8	365	10	254	8	203	61	28	55	25
AX-20	10.9	41.3	2.4	9.1	12	305	26	607	1/2 ¹	21 1/8	537	10	254	8	203	75	34	69	31
AX-40	21.7	82.2	11.3	42.8	16	356	29	737	1/2 ¹	22	557	14	356	12	305	127	58	111	50
AX-60	33.6	127.2	11.3	42.8	16	356	43	1073	1/2 ¹	36 3/8	918	14	356	12	305	160	73	144	65
AX-80	44.4	168.1	22.6	85.5	24	610	29	725	1 ¹	16 3/8	429	20	508	18	457	250	113	230	104
AX-100	55.7	211.8	22.6	85.5	24	610	33	840	1 ¹	21 1/2	546	20	508	18	457	281	127	261	118
AX-120	68.0	257.4	34.0	128.7	24	610	41	1051	1 ¹	29 1/2	749	20	508	18	457	326	148	306	139
AX-144	77.0	291.5	34.0	128.7	24	610	46	1170	1 ¹	34 3/8	873	20	508	18	457	347	157	327	148
AX-180	90.0	340.7	34.0	128.7	24	610	54	1357	1 ¹	41 3/4	1060	20	508	18	457	368	167	348	159
AX-200	110.0	416.4	34.0	128.7	24	610	64	1624	1 ¹	52 1/4	1327	20	508	18	457	424	192	404	183
AX-240	132.0	500.0	46.0	174.0	30	762	51	1295	1 ¹	35	889	24	610	22	559	627	284	602	273
AX-260	159.0	600.0	56.0	212.0	30	762	62	1581	1 1/4 ²	44 1/4	1124	24	610	22	559	708	321	683	310
AX-280	211.0	800.0	84.0	318.0	30	762	80	2032	1 1/4 ²	62	1575	24	610	22	559	895	406	870	395

All dimensions and weights are approximate.

Job Name _____	Notes _____
Engineer _____	_____
Contractor _____	_____
P.O. No. _____	_____
Sales Rep. _____	_____
Model No. _____	_____





EXTROL®

Hydronic Expansion Tanks: Horizontal AX Series ASME

300 PSIG Working Pressure

Construction

Shell	ASME Approved Steel
Diaphragm	Heavy Duty Butyl/EPDM
System Connection	NPTF ¹ Malleable Iron Center NPTM ² Steel Pipe, Top Offset
Finish	Red Oxide Primer
Air Valve	Schrader Valve w/EPDM Seats
Factory Precharge	12 PSIG (.8 bar)

Performance

Maximum Operating Temperature	240°F (115°C)
Maximum Working Pressure	300 PSIG (12 bar)
Warranty	3-Years

Application

- For use in closed, non-potable hydronic heating and chilled water systems.
- Designed to meet all ASME Code Section VIII, Division 1 standards.
- Available with optional sight glass and seismic restraints (saddles).
- Suitable in propylene glycol applications with mixtures up to 50%.

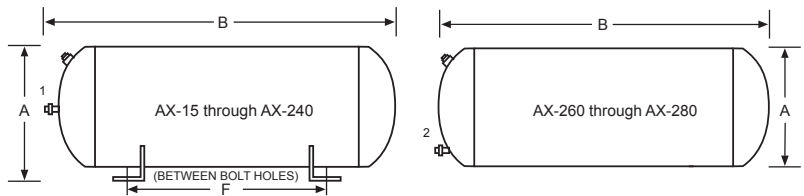
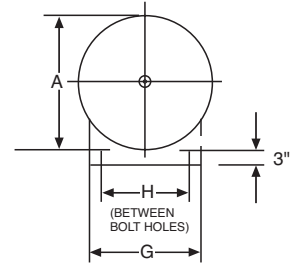

Horizontal ASME Models

Model Number	Tank Volume		Max. Accept. Volume		A Tank Diameter		B Tank Length		Sys. Conn	Restraints (Saddles) for Horizontal Mounting						Ship Wt. with Restraints (Saddles)		Shipping Weight	
										F		G		H					
	Gal	Lit	Gal	Lit	In	mm	In	mm		In	mm	In	mm	In	mm	Lbs	Kg	Lbs	Kg
AX-15	8.0	30.3	2.4	9.1	12	305	19	489	½ ¹	14¾	365	10	254	8	203	65	29	59	27
AX-20	10.9	41.3	2.4	9.1	12	305	26	607	½ ¹	21⅞	537	10	254	8	203	80	36	74	34
AX-40	21.7	82.2	11.3	42.8	16	356	29	737	½ ¹	22	557	14	356	12	305	134	61	118	54
AX-60	33.6	127.2	11.3	42.8	16	356	43	1073	½ ¹	36⅞	918	14	356	12	305	170	77	154	70
AX-80	44.4	168.1	22.6	85.5	24	610	29	725	1 ¹	16⅞	429	20	508	18	457	265	120	245	111
AX-100	55.7	211.8	22.6	85.5	24	610	33	840	1 ¹	21½	546	20	508	18	457	299	136	279	127
AX-120	68.0	257.4	34.0	128.7	24	610	41	1051	1 ¹	29½	749	20	508	18	457	347	157	327	148
AX-144	77.0	291.5	34.0	128.7	24	610	46	1170	1 ¹	34¾	873	20	508	18	457	370	168	350	159
AX-180	90.0	340.7	34.0	128.7	24	610	54	1357	1 ¹	41¼	1060	20	508	18	457	392	178	372	169
AX-200	110.0	416.4	34.0	128.7	24	610	64	1624	1 ¹	52¼	1327	20	508	18	457	450	204	430	195
AX-240	132.0	500.0	46.0	174.0	30	762	51	1295	1 ¹	35	889	24	610	22	559	667	303	642	291
AX-260	159.0	600.0	56.0	212.0	30	762	62	1581	1¼ ²	44¼	1124	24	610	22	559	753	342	728	330
AX-280	211.0	800.0	84.0	318.0	30	762	80	2032	1¼ ²	62	1575	24	610	22	559	755	433	930	422

All dimensions and weights are approximate.

Job Name _____	Notes _____
Engineer _____	_____
Contractor _____	_____
P.O. No. _____	_____
Sales Rep. _____	_____
Model No. _____	_____





125 PSIG Working Pressure

Construction

Shell	ASME Approved Steel
Diaphragm	Heavy Duty Butyl/EPDM
System Connection	NPTF ¹ Malleable Iron Center NPTM ² Steel Pipe, Top Offset
Finish	Red Oxide Primer
Air Valve	Schrader Valve w/EPDM Seats
Factory Precharge	12 PSIG (.8 bar)

Performance

Maximum Operating Temperature	240°F (115°C)
Maximum Working Pressure	125 PSIG (8.6 bar)
Warranty	3-Years

Application

- For use in closed, non-potable hydronic heating and chilled water systems.
- Designed to meet all ASME Code Section VIII, Division 1 standards.
- Available with optional sight glass and seismic restraints.
- Suitable in propylene glycol applications with mixtures up to 50%.
- Deep drawn models are lighter, stronger and more compact than traditional head and shell construction.

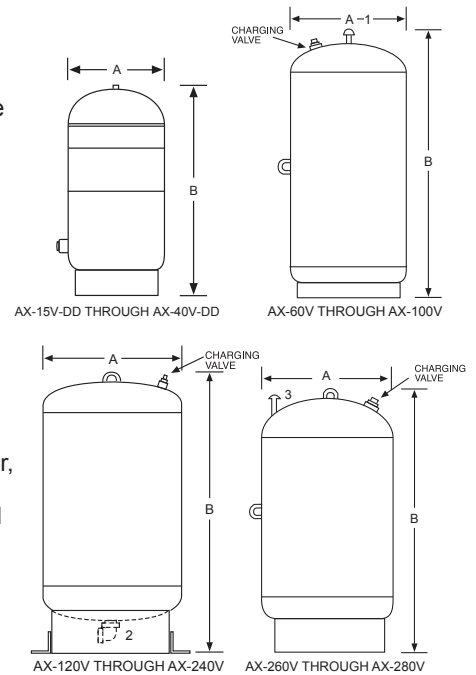

Deep Drawn ASME Models

Model Number	Tank Volume		Max. Accept. Volume		A Tank Diameter		B Tank Height		Sys. Conn	Shipping Weight	
	Gal	Lit	Gal	Lit	In	mm	In	mm		In	Lbs
AX-15V-DD	8.6	33	3.2	12.1	12	305	22	559	3/4" ¹	38	17
AX-20V-DD	16.5	63	11.3	43	15	381	25	636	3/4" ¹	51	23
AX-40V-DD	23	88	11.3	43	15	381	33	838	3/4" ¹	72	34

Head & Shell ASME Models

Model Number	Tank Volume		Max. Accept. Volume		A Tank Diameter		B Tank Height		Sys. Conn	Shipping Weight	
	Gal	Lit	Gal	Lit	In	mm	In	mm		In	Lbs
AX-60V	33.6	127.2	11.3	42.8	16	356	45	1143	1/2" ¹	99	45
AX-80V	44.4	168.1	22.6	85.5	24	610	29	737	1" ¹	166	75
AX-100V	55.7	211.8	22.6	85.5	24	610	34	863	1" ¹	178	81
AX-120V	68.0	257.4	34.0	128.7	24	610	47	1194	1 ²	220	100
AX-144V	77.0	291.5	34.0	128.7	24	610	52	1321	1 ²	232	105
AX-180V	90.0	340.7	34.0	128.7	24	610	60	1524	1 ²	241	109
AX-200V	110.0	416.4	34.0	128.7	24	610	66	1676	1 ²	269	122
AX-240V	132.0	500.0	46.0	174.0	30	762	58	1473	1 ²	432	196
AX-260V	159.0	600.0	56.0	212.0	30	762	65	1651	1 1/4" ³	475	215
AX-280V	211.0	800.0	84.0	318.0	30	762	82	2083	1 1/4" ³	599	272

All dimensions and weights are approximate.

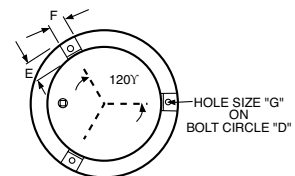

BOTTOM VIEW

Optional Seismic Restraints

Tank Diameter	Bolt Circle	Dim. E	Dim. F	Hole Size G
B	D	E	F	G
12	12 3/4	2	2	3/16
16 1/4	14 3/4	2	2	3/16
24	18	2	2	3/16
30	27	3	3	3/4

Job Name _____	Notes _____
Engineer _____	_____
Contractor _____	_____
P.O. No. _____	_____
Sales Rep. _____	_____
Model No. _____	_____





150 PSIG Working Pressure

Construction

Shell	ASME Approved Steel
Diaphragm	Heavy Duty Butyl/EPDM
System Connection	NPTF ¹ Malleable Iron Center NPTF ² Malleable Iron Bottom NPTM ³ Steel Pipe, Top Offset
Finish	Red Oxide Primer
Air Valve	Schrader Valve w/EPDM Seats
Factory Precharge	12 PSIG (.8 bar)

Performance

Maximum Operating Temperature	240°F (115°C)
Maximum Working Pressure	150 PSIG (10.3 bar)
Warranty	3-Years

Application

- For use in closed, non-potable hydronic heating and chilled water systems.
- Designed to meet all ASME Code Section VIII, Division 1 standards.
- Available with optional sight glass and seismic restraints.
- Suitable in propylene glycol applications with mixtures up to 50%.
- Deep drawn models are lighter, stronger and more compact than traditional head and shell construction.

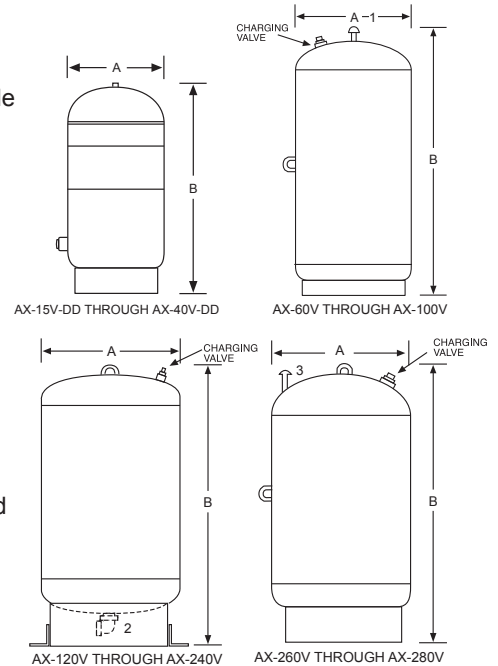

Deep Drawn ASME Models

Model Number	Tank Volume		Max. Accept. Volume		A Tank Diameter		B Tank Height		Sys. Conn	Shipping Weight	
	Gal	Lit	Gal	Lit	In	mm	In	mm		In	Lbs
AX-15V-DD	8.6	33	3.2	12.1	12	305	22	559	3/4" ¹	42	19
AX-20V-DD	16.5	63	11.3	43	15	381	25	636	3/4" ¹	48	22
AX-40V-DD	23	88	11.3	43	15	381	33	838	3/4" ¹	96	44

Head & Shell ASME Models

Model Number	Tank Volume		Max. Accept. Volume		A Tank Diameter		B Tank Height		Sys. Conn	Shipping Weight	
	Gal	Lit	Gal	Lit	In	mm	In	mm		In	Lbs
AX-60V	33.6	127.2	11.3	42.8	16	356	45	1143	1/2" ¹	104	47
AX-80V	44.4	168.1	22.6	85.5	24	610	29	737	1" ¹	171	78
AX-100V	55.7	211.8	22.6	85.5	24	610	34	863	1" ¹	190	86
AX-120V	68.0	257.4	34.0	128.7	24	610	47	1194	1 ²	220	100
AX-144V	77.0	291.5	34.0	128.7	24	610	52	1321	1 ²	255	116
AX-180V	90.0	340.7	34.0	128.7	24	610	60	1524	1 ²	276	125
AX-200V	110.0	416.4	34.0	128.7	24	610	66	1676	1 ²	300	136
AX-240V	132.0	500.0	46.0	174.0	30	762	58	1473	1 ²	426	193
AX-260V	159.0	600.0	56.0	212.0	30	762	65	1651	1 1/4" ³	467	212
AX-280V	211.0	800.0	84.0	318.0	30	762	82	2083	1 1/4" ³	611	277

All dimensions and weights are approximate.

Optional Seismic Restraints

Tank Diameter	Bolt Circle	Dim. E	Dim. F	Hole Size
B	D	E	F	G
12	12 3/4	2	2	9/16
16 1/4	14 3/4	2	2	9/16
24	18	2	2	9/16
30	27	3	3	3/4

Job Name _____	Notes _____
Engineer _____	_____
Contractor _____	_____
P.O. No. _____	_____
Sales Rep. _____	_____
Model No. _____	_____





EXTROL®

Hydronic Expansion Tanks: Vertical AX Series ASME

175 PSIG Working Pressure

Construction

Shell	ASME Approved Steel
Diaphragm	Heavy Duty Butyl/EPDM
System Connection	NPTF ¹ Malleable Iron Center NPTF ² Malleable Iron Bottom NPTM ³ Steel Pipe, Top Offset
Finish	Red Oxide Primer
Air Valve	Schrader Valve w/EPDM Seats
Factory Precharge	12 PSIG (.8 bar)

Performance

Maximum Operating Temperature	240°F (115°C)
Maximum Working Pressure	175 PSIG (12 bar)
Warranty	3-Years

Application

- For use in closed, non-potable hydronic heating and chilled water systems.
- Designed to meet all ASME Code Section VIII, Division 1 standards.
- Available with optional sight glass and seismic restraints.
- Suitable in propylene glycol applications with mixtures up to 50%.

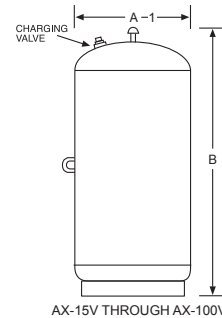

AX-15V THROUGH AX-100V

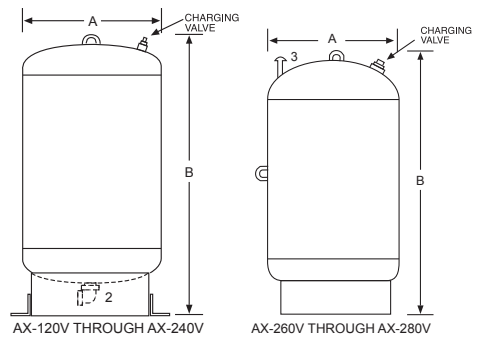

AX-120V THROUGH AX-240V

AX-260V THROUGH AX-280V

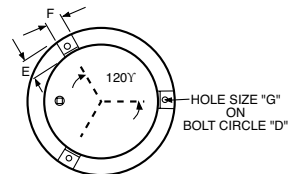

BOTTOM VIEW

Vertical ASME Models

Model Number	Tank Volume		Max. Accept. Volume		A Tank Diameter		B Tank Height		Sys. Conn	Shipping Weight	
	Gal	Lit	Gal	Lit	In	mm	In	mm		In	Lbs
AX-15V	8.0	30.3	2.4	9.1	12	305	20	508	½ ¹	49	22
AX-20V	10.9	41.3	2.4	9.1	12	305	27	686	½ ¹	61	28
AX-40V	21.7	82.2	11.3	42.8	16	356	30	762	½ ¹	99	45
AX-60V	33.6	127.2	11.3	42.8	16	356	45	1143	½ ¹	127	58
AX-80V	44.4	168.1	22.6	85.5	24	610	29	737	1 ¹	201	91
AX-100V	55.7	211.8	22.6	85.5	24	610	34	864	1 ¹	229	104
AX-120V	68.0	257.4	34.0	128.7	24	610	47	1194	1 ²	278	126
AX-144V	77.0	291.5	34.0	128.7	24	610	52	1321	1 ²	299	136
AX-180V	90.0	340.7	34.0	128.7	24	610	60	1524	1 ²	352	160
AX-200V	110.0	416.4	34.0	128.7	24	610	66	1676	1 ²	377	171
AX-240V	132.0	500.0	46.0	174.0	30	762	58	1473	1 ²	521	236
AX-260V	159.0	600.0	56.0	212.0	30	762	65	1651	1¼ ³	598	271
AX-280V	211.0	800.0	84.0	318.0	30	762	82	2083	1¼ ³	767	348

All dimensions and weights are approximate.

Optional Seismic Restraints

Tank Diameter	Bolt Circle	Dim. E	Dim. F	Hole Size G
B	D	E	F	G
12	12¾	2	2	¼/16
16¼	14¾	2	2	¼/16
24	18	2	2	¼/16
30	27	3	3	¾/4

Job Name _____	Notes _____
Engineer _____	_____
Contractor _____	_____
P.O. No. _____	_____
Sales Rep. _____	_____
Model No. _____	_____





EXTROL®

Hydronic Expansion Tanks: Vertical AX Series ASME

250 PSIG Working Pressure

Construction

Shell	ASME Approved Steel
Diaphragm	Heavy Duty Butyl/EPDM
System Connection	NPTF ¹ Malleable Iron Center NPTF ² Malleable Iron Bottom NPTM ³ Steel Pipe, Top Offset
Finish	Red Oxide Primer
Air Valve	Schrader Valve w/EPDM Seats
Factory Precharge	12 PSIG (.8 bar)

Performance

Maximum Operating Temperature	240°F (115°C)
Maximum Working Pressure	250 PSIG (17.2 bar)
Warranty	3-Years

Application

- For use in closed, non-potable hydronic heating and chilled water systems.
- Designed to meet all ASME Code Section VIII, Division 1 standards.
- Available with optional sight glass and seismic restraints.
- Suitable in propylene glycol applications with mixtures up to 50%.

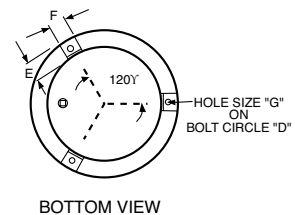
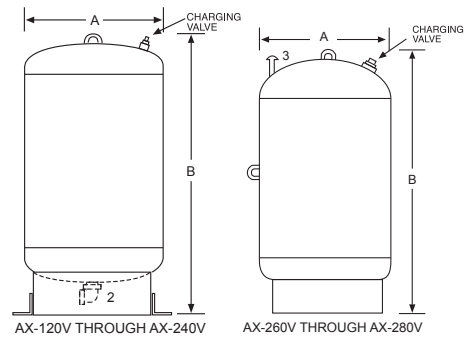
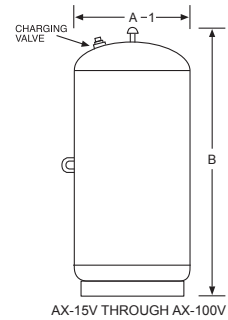

BOTTOM VIEW

Vertical ASME Models

Model Number	Tank Volume		Max. Accept. Volume		A Tank Diameter		B Tank Height		Sys. Conn	Shipping Weight	
	Gal	Lit	Gal	Lit	In	mm	In	mm		Lbs	Kg
AX-15V	8.0	30.3	2.4	9.1	12	305	20	508	½ ¹	59	27
AX-20V	10.9	41.3	2.4	9.1	12	305	27	686	½ ¹	71	32
AX-40V	21.7	82.2	11.3	42.8	16	356	30	762	½ ¹	114	52
AX-60V	33.6	127.2	11.3	42.8	16	356	45	1143	½ ¹	147	67
AX-80V	44.4	168.1	22.6	85.5	24	610	29	737	1 ¹	233	106
AX-100V	55.7	211.8	22.6	85.5	24	610	34	864	1 ¹	264	120
AX-120V	68.0	257.4	34.0	128.7	24	610	47	1194	1 ²	321	146
AX-144V	77.0	291.5	34.0	128.7	24	610	52	1321	1 ²	345	156
AX-180V	90.0	340.7	34.0	128.7	24	610	60	1524	1 ²	407	185
AX-200V	110.0	416.4	34.0	128.7	24	610	66	1676	1 ²	435	197
AX-240V	132.0	500.0	46.0	174.0	30	762	58	1473	1 ²	602	273
AX-260V	159.0	600.0	56.0	212.0	30	762	65	1651	1¼ ³	690	313
AX-280V	211.0	800.0	84.0	318.0	30	762	82	2083	1¼ ³	885	401

All dimensions and weights are approximate.

Optional Seismic Restraints

Tank Diameter	Bolt Circle	Dim. E	Dim. F	Hole Size G
B	D			
12	12¾	2	2	⅜
16¼	14¾	2	2	⅜
24	18	2	2	⅜
30	27	3	3	¾

Job Name _____	Notes _____
Engineer _____	_____
Contractor _____	_____
P.O. No. _____	_____
Sales Rep. _____	_____
Model No. _____	_____





EXTROL®

Hydronic Expansion Tanks: Vertical AX Series ASME

300 PSIG Working Pressure

Construction

Shell	ASME Approved Steel
Diaphragm	Heavy Duty Butyl/EPDM
System Connection	NPTF ¹ Malleable Iron Center NPTF ² Malleable Iron Bottom NPTM ³ Steel Pipe, Top Offset
Finish	Red Oxide Primer
Air Valve	Schrader Valve w/EPDM Seats
Factory Precharge	12 PSIG (.8 bar)

Performance

Maximum Operating Temperature	240°F (115°C)
Maximum Working Pressure	300 PSIG (20.7 bar)
Warranty	3-Years

Application

- For use in closed, non-potable hydronic heating and chilled water systems.
- Designed to meet all ASME Code Section VIII, Division 1 standards.
- Available with optional sight glass and seismic restraints.
- Suitable in propylene glycol applications with mixtures up to 50%.

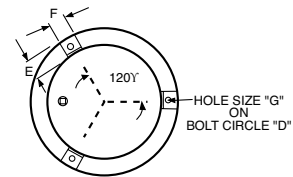
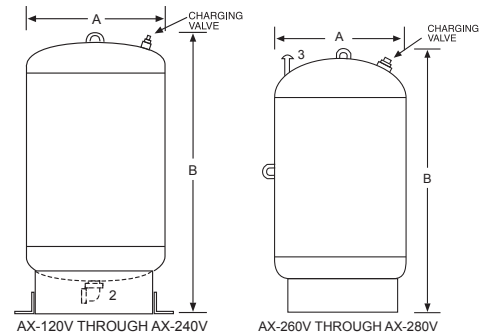
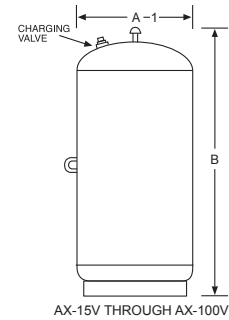

BOTTOM VIEW

Vertical ASME Models

Model Number	Tank Volume		Max. Accept. Volume		A Tank Diameter		B Tank Height		Sys. Conn	Shipping Weight	
	Gal	Lit	Gal	Lit	In	mm	In	mm		Lbs	Kg
AX-15V	8.0	30.3	2.4	9.1	12	305	20	508	½ ¹	62	28
AX-20V	10.9	41.3	2.4	9.1	12	305	27	686	½ ¹	75	34
AX-40V	21.7	82.2	11.3	42.8	16	356	30	762	½ ¹	122	55
AX-60V	33.6	127.2	11.3	42.8	16	356	45	1143	½ ¹	157	71
AX-80V	44.4	168.1	22.6	85.5	24	610	29	737	1 ¹	248	112
AX-100V	55.7	211.8	22.6	85.5	24	610	34	864	1 ¹	282	128
AX-120V	68.0	257.4	34.0	128.7	24	610	47	1194	1 ²	342	155
AX-144V	77.0	291.5	34.0	128.7	24	610	52	1321	1 ²	368	167
AX-180V	90.0	340.7	34.0	128.7	24	610	60	1524	1 ²	434	197
AX-200V	110.0	416.4	34.0	128.7	24	610	66	1676	1 ²	464	210
AX-240V	132.0	500.0	46.0	174.0	30	762	58	1473	1 ²	642	291
AX-260V	159.0	600.0	56.0	212.0	30	762	65	1651	1¼ ³	736	334
AX-280V	211.0	800.0	84.0	318.0	30	762	82	2083	1¼ ³	945	429

All dimensions and weights are approximate.

Optional Seismic Restraints

Tank Diameter	Bolt Circle	Dim. E	Dim. F	Hole Size
B	D	E	F	G
12	12¾	2	2	9/16
16¼	14¾	2	2	9/16
24	18	2	2	9/16
30	27	3	3	¾

Job Name _____	Notes _____
Engineer _____	_____
Contractor _____	_____
P.O. No. _____	_____
Sales Rep. _____	_____
Model No. _____	_____





125 PSIG Working Pressure

Construction

Shell	ASME Approved Steel
Bladder Design	Full Acceptance; Replaceable
Bladder Thickness	.100 In Minimum
System Connection	NPTF SA-105 Steel
Finish	Red Oxide Primer
Air Valve	Schrader Valve w/EPDM Seats
Factory Precharge	12 PSIG (.8 bar)

Performance

Maximum Operating Temperature	240°F (115°C)
Maximum Working Pressure	125 PSIG (8.6 bar)
Warranty	3-Years

Application

- For use in closed, non-potable hydronic heating and chilled water systems.
- Replaceable, full acceptance bladder design.
- Meets all ASME Code Section VIII, Division 1 standards.
- Available with optional sight glass and seismic restraints.
- Suitable in propylene glycol applications with mixtures up to 50%.

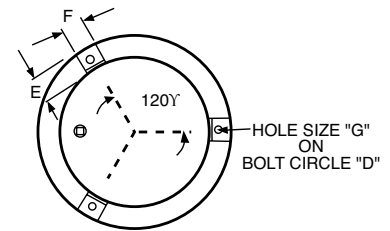
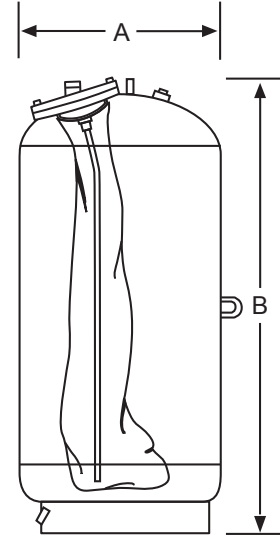

BOTTOM VIEW

ASME Models

Model Number	Tank Volume		A Tank Diameter		B Tank Height		C Stand Diameter		System Conn. (NPTF)		Drain Conn.		Shipping Weight	
	Gal	Lit	In	mm	In	mm	In	mm	In	mm	In	mm	Lbs	Kg
200-L	53	200	24	610	38	956	19	483	1	25	3/4	19	190	86
300-L	80	300	24	610	52	1308	19	483	1	25	3/4	19	230	104
400-L	106	400	24	610	66	1662	19	483	1	25	3/4	19	275	125
500-L	132	500	24	610	79	2006	19	483	1	25	3/4	19	311	141
600-L	158	600	30	762	64	1619	24	610	1 1/2	38	1	25	439	199
800-L	211	800	30	762	82	2076	24	610	1 1/2	38	1	25	543	246
1000-L	264	1000	36	914	74	1867	30	762	1 1/2	38	1 1/4	32	609	276
1200-L	317	1200	36	914	86	2181	30	762	1 1/2	38	1 1/4	32	700	318
1400-L	370	1400	36	914	98	2496	30	762	1 1/2	38	1 1/4	32	783	355
1600-L	422	1600	48	1219	69	1756	42	1067	1 1/2	38	1 1/2	38	1106	502
2000-L	528	2000	48	1219	84	2145	42	1067	1 1/2	38	1 1/2	38	1284	582
2500-L	660	2500	48	1219	101	2562	42	1067	2	50	1 1/2	38	1544	700
3000-L	792	3000	48	1219	118	3000	42	1067	2	50	1 1/2	38	1719	780
3500-L	925	3500	54	1372	111	2820	42	1067	2	50	1 1/2	38	2187	992
4000-L	1057	4000	54	1372	125	3175	42	1067	2	50	1 1/2	38	2352	1067
5000-L	1321	5000	60	1524	128	3251	42	1067	2	50	1 1/2	38	2450	1111
7500-L	1980	7500	72	1829	127	3226	54	1372	3	76	1 1/2	38	4000	1818
7500-LCAN	1980	7500	72	1829	144	3658	54	1372	3	76	1 1/2	38	4000	1818
10000-L	2640	10000	72	1829	159	4039	54	1372	3	76	1 1/2	38	4900	2227
15000-L	3963	15000	72	1829	233	5918	54	1372	3	76	1 1/2	38	6000	2727

All dimensions and weights are approximate.

Optional Seismic Restraints

Tank Diameter	Bolt Circle	Dim.	Dim.	Hole Size
B	D	E	F	G
24	21	2	2	9/16
30	27	3	3	1 1/16
36	34	4	4	7/8
48	46	4	4	7/8
54	46	4	4	7/8
60	46	4	4	7/8
72	58	4	4	1

Job Name _____	Notes _____
Engineer _____	_____
Contractor _____	_____
P.O. No. _____	_____
Sales Rep. _____	_____
Model No. _____	_____





150 PSIG Working Pressure

Construction

Shell	ASME Approved Steel
Bladder Design	Full Acceptance; Replaceable
Bladder Thickness	.100 In Minimum
System Connection	NPTF SA-105 Steel
Finish	Red Oxide Primer
Air Valve	Schrader Valve w/EPDM Seats
Factory Precharge	12 PSIG (.8 bar)

Performance

Maximum Operating Temperature	240°F (115°C)
Maximum Working Pressure	150 PSIG (10.3 bar)
Warranty	3-Years

Application

- For use in closed, non-potable hydronic heating and chilled water systems.
- Replaceable, full acceptance bladder design.
- Meets all ASME Code Section VIII, Division 1 standards.
- Available with optional sight glass and seismic restraints.
- Suitable in propylene glycol applications with mixtures up to 50%.

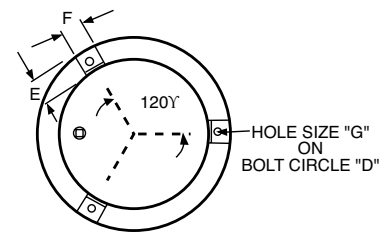
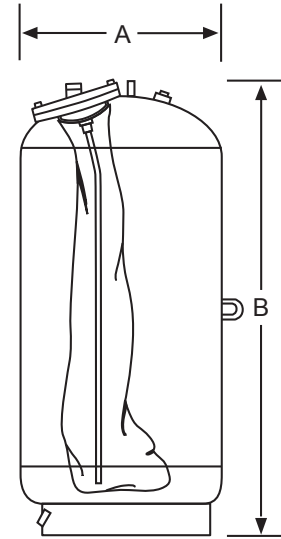

BOTTOM VIEW

ASME Models

Model Number	Tank Volume		A Tank Diameter		B Tank Height		C Stand Diameter		System Conn. (NPTF)		Drain Conn.		Shipping Weight	
	Gal	Lit	In	mm	In	mm	In	mm	In	mm	In	mm	Lbs	Kg
200-L	53	200	24	610	38	956	19	483	1	25	3/4	19	205	93
300-L	80	300	24	610	52	1308	19	483	1	25	3/4	19	292	133
400-L	106	400	24	610	66	1662	19	483	1	25	3/4	19	343	156
500-L	132	500	24	610	79	2006	19	483	1	25	3/4	19	372	169
600-L	158	600	30	762	64	1619	24	610	1 1/2	38	1	25	510	231
800-L	211	800	30	762	82	2076	24	610	1 1/2	38	1	25	565	257
1000-L	264	1000	36	914	74	1867	30	762	1 1/2	38	1 1/4	32	750	340
1200-L	317	1200	36	914	86	2181	30	762	1 1/2	38	1 1/4	32	860	390
1400-L	370	1400	36	914	98	2496	30	762	1 1/2	38	1 1/4	32	970	440
1600-L	422	1600	48	1219	69	1756	42	1067	1 1/2	38	1 1/2	38	1425	647
2000-L	528	2000	48	1219	84	2145	42	1067	1 1/2	38	1 1/2	38	1675	760
2500-L	660	2500	48	1219	101	2562	42	1067	2	50	1 1/2	38	1945	883
3000-L	792	3000	48	1219	118	3000	42	1067	2	50	1 1/2	38	2225	1010
3500-L	925	3500	54	1372	111	2820	42	1067	2	50	1 1/2	38	2375	1078
4000-L	1057	4000	54	1372	125	3175	42	1067	2	50	1 1/2	38	2640	1198
5000-L	1321	5000	60	1524	128	3251	42	1067	2	50	1 1/2	38	3740	1700
7500-L	1980	7500	72	1829	127	3226	54	1372	3	76	1 1/2	38	4300	1950
7500-LCAN	1980	7500	72	1829	144	3658	54	1372	3	76	1 1/2	38	4300	1950
10000-L	2640	10000	72	1829	159	4039	54	1372	3	76	1 1/2	38	5300	2404
15000-L	3963	15000	72	1829	233	5918	54	1372	3	76	1 1/2	38	7600	3447

Optional Seismic Restraints

Tank Diameter	Bolt Circle	Dim. E	Dim. F	Hole Size
B	D	E	F	G
24	21	2	2	9/16
30	27	3	3	1 1/16
36	34	4	4	7/8
48	46	4	4	7/8
54	46	4	4	7/8
60	46	4	4	7/8
72	58	4	4	1

All dimensions and weights are approximate.

Job Name _____	Notes _____
Engineer _____	_____
Contractor _____	_____
P.O. No. _____	_____
Sales Rep. _____	_____
Model No. _____	_____





175 PSIG Working Pressure

Construction

Shell	ASME Approved Steel
Bladder Design	Full Acceptance; Replaceable
Bladder Thickness	.100 In Minimum
System Connection	NPTF SA-105 Steel
Finish	Red Oxide Primer
Air Valve	Schrader Valve w/EPDM Seats
Factory Precharge	12 PSIG (.8 bar)

Performance

Maximum Operating Temperature	240°F (115°C)
Maximum Working Pressure	175 PSIG (12 bar)
Warranty	3-Years

Application

- For use in closed, non-potable hydronic heating and chilled water systems.
- Replaceable, full acceptance bladder design.
- Meets all ASME Code Section VIII, Division 1 standards.
- Available with optional sight glass and seismic restraints.
- Suitable in propylene glycol applications with mixtures up to 50%.

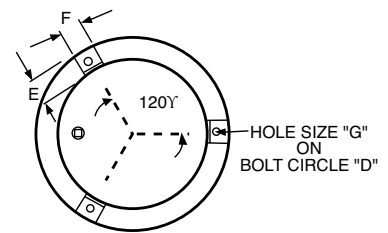
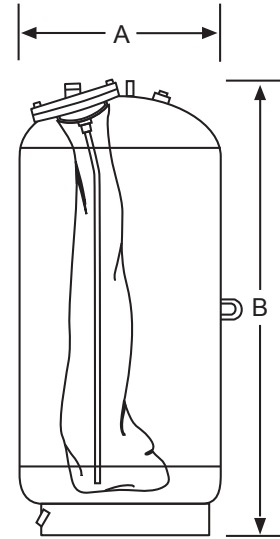

BOTTOM VIEW

ASME Models

Model Number	Tank Volume		A Tank Diameter		B Tank Height		C Stand Diameter		System Conn. (NPTF)		Drain Conn.		Shipping Weight	
	Gal	Lit	In	mm	In	mm	In	mm	In	mm	In	mm	Lbs	Kg
200-L	53	200	24	610	38	956	19	483	1	25	3/4	19	250	114
300-L	80	300	24	610	52	1308	19	483	1	25	3/4	19	320	146
400-L	106	400	24	610	66	1662	19	483	1	25	3/4	19	375	170
500-L	132	500	24	610	79	2006	19	483	1	25	3/4	19	435	198
600-L	158	600	30	762	64	1619	24	610	1 1/2	38	1	25	595	270
800-L	211	800	30	762	82	2076	24	610	1 1/2	38	1	25	620	282
1000-L	264	1000	36	914	74	1867	30	762	1 1/2	38	1 1/4	32	750	340
1200-L	317	1200	36	914	86	2181	30	762	1 1/2	38	1 1/4	32	860	390
1400-L	370	1400	36	914	98	2496	30	762	1 1/2	38	1 1/4	32	970	440
1600-L	422	1600	48	1219	69	1756	42	1067	1 1/2	38	1 1/2	38	1615	733
2000-L	528	2000	48	1219	84	2145	42	1067	1 1/2	38	1 1/2	38	2386	1082
2500-L	660	2500	48	1219	101	2562	42	1067	2	50	1 1/2	38	2411	1093
3000-L	792	3000	48	1219	118	3000	42	1067	2	50	1 1/2	38	2500	1133
3500-L	925	3500	54	1372	111	2820	42	1067	2	50	1 1/2	38	2620	1188
4000-L	1057	4000	54	1372	125	3175	42	1067	2	50	1 1/2	38	3000	1360
5000-L	1321	5000	60	1524	128	3251	42	1067	2	50	1 1/2	38	4100	1863
7500-L	1980	7500	72	1829	127	3226	54	1372	3	76	1 1/2	38	4500	2045
7500-LCAN	1980	7500	72	1829	144	3658	54	1372	3	76	1 1/2	38	4500	2045
10000-L	2640	10000	72	1829	159	4039	54	1372	3	76	1 1/2	38	5500	2500
15000-L	3963	15000	72	1829	233	5918	54	1372	3	76	1 1/2	38	8650	3925

Optional Seismic Restraints

Tank Diameter	Bolt Circle	Dim. E	Dim. F	Hole Size
B	D	E	F	G
24	21	2	2	9/16
30	28	4	4	7/8
36	34	4	4	7/8
48	46	4	4	7/8
54	46	4	4	7/8
60	46	4	4	7/8
72	58	4	4	1

All dimensions and weights are approximate.

Job Name _____	Notes _____
Engineer _____	_____
Contractor _____	_____
P.O. No. _____	_____
Sales Rep. _____	_____
Model No. _____	_____





250 PSIG Working Pressure

Construction

Shell	ASME Approved Steel
Bladder Design	Full Acceptance; Replaceable
Bladder Thickness	.100 In Minimum
System Connection	NPTF SA-105 Steel
Finish	Red Oxide Primer
Air Valve	Schrader Valve w/EPDM Seats
Factory Precharge	12 PSIG (.8 bar)

Performance

Maximum Operating Temperature	240°F (115°C)
Maximum Working Pressure	250 PSIG (17.2 bar)
Warranty	3-Years

Application

- For use in closed, non-potable hydronic heating and chilled water systems.
- Replaceable, full acceptance bladder design.
- Meets all ASME Code Section VIII, Division 1 standards.
- Available with optional sight glass and seismic restraints.
- Suitable in propylene glycol applications with mixtures up to 50%.

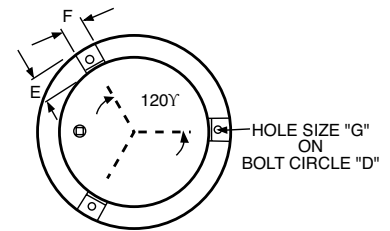
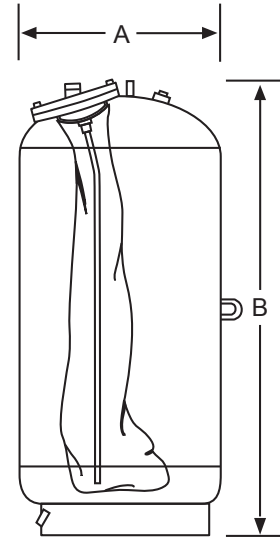

BOTTOM VIEW

ASME Models

Model Number	Tank Volume		A Tank Diameter		B Tank Height		C Stand Diameter		System Conn. (NPTF)		Drain Conn.		Shipping Weight	
	Gal	Lit	In	mm	In	mm	In	mm	In	mm	In	mm	Lbs	Kg
200-L	53	200	24	610	38	956	19	483	1	25	3/4	19	290	132
300-L	80	300	24	610	52	1308	19	483	1	25	3/4	19	385	175
400-L	106	400	24	610	66	1662	19	483	1	25	3/4	19	465	211
500-L	132	500	24	610	79	2006	19	483	1	25	3/4	19	545	248
600-L	158	600	30	762	64	1619	24	610	1 1/2	38	1	25	720	327
800-L	211	800	30	762	82	2076	24	610	1 1/2	38	1	25	905	411
1000-L	264	1000	36	914	74	1867	30	762	1 1/2	38	1 1/4	32	1015	461
1200-L	317	1200	36	914	86	2181	30	762	1 1/2	38	1 1/4	32	1175	533
1400-L	370	1400	36	914	98	2496	30	762	1 1/2	38	1 1/4	32	1335	606
1600-L	422	1600	48	1219	69	1756	42	1067	1 1/2	38	1 1/2	38	1916	869
2000-L	528	2000	48	1219	84	2145	42	1067	1 1/2	38	1 1/2	38	2410	1093
2500-L	660	2500	48	1219	101	2562	42	1067	2	50	1 1/2	38	2585	1173
3000-L	792	3000	48	1219	118	3000	42	1067	2	50	1 1/2	38	2950	1338
3500-L	925	3500	54	1372	111	2820	42	1067	2	50	1 1/2	38	3660	1661
4000-L	1057	4000	54	1372	125	3175	42	1067	2	50	1 1/2	38	4080	1851
5000-L	1321	5000	60	1524	128	3251	42	1067	2	50	1 1/2	38	4200	1909
7500-L	1980	7500	72	1829	127	3226	54	1372	3	76	1 1/2	38	5550	2522
7500-LCAN	1980	7500	72	1829	144	3658	54	1372	3	76	1 1/2	38	5550	2522
10000-L	2640	10000	72	1829	159	4039	54	1372	3	76	1 1/2	38	6800	3090
15000-L	3963	15000	72	1829	233	5918	54	1372	3	76	1 1/2	38	9800	4454

Optional Seismic Restraints

Tank Diameter	Bolt Circle	Dim. E	Dim. F	Hole Size
B	D	E	F	G
24	21	2	2	9/16
30	28	4	4	7/8
36	34	4	4	7/8
48	46	4	4	7/8
54	46	4	4	7/8
60	46	4	4	7/8
72	58	4	4	1

All dimensions and weights are approximate.

Job Name _____	Notes _____
Engineer _____	_____
Contractor _____	_____
P.O. No. _____	_____
Sales Rep. _____	_____
Model No. _____	_____





300 PSIG Working Pressure

Construction

Shell	ASME Approved Steel
Bladder Design	Full Acceptance; Replaceable
Bladder Thickness	.100 In Minimum
System Connection	NPTF SA-105 Steel
Finish	Red Oxide Primer
Air Valve	Schrader Valve w/EPDM Seats
Factory Precharge	12 PSIG (.8 bar)

Performance

Maximum Operating Temperature	240°F (115°C)
Maximum Working Pressure	300 PSIG (20.7 bar)
Warranty	3-Years

Application

- For use in closed, non-potable hydronic heating and chilled water systems.
- Replaceable, full acceptance bladder design.
- Meets all ASME Code Section VIII, Division 1 standards.
- Available with optional sight glass and seismic restraints.
- Suitable in propylene glycol applications with mixtures up to 50%.

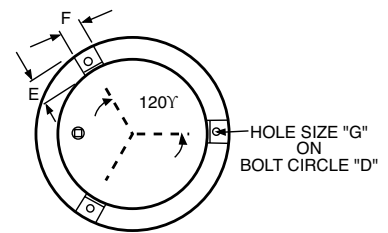
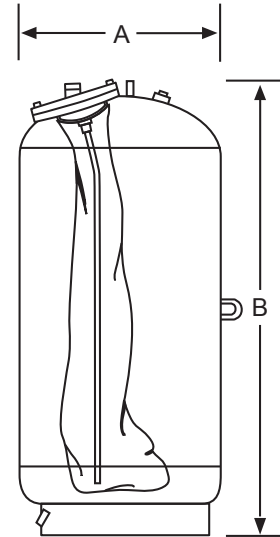

BOTTOM VIEW

ASME Models

Model Number	Tank Volume		A Tank Diameter		B Tank Height		C Stand Diameter		System Conn. (NPTF)		Drain Conn.		Shipping Weight	
	Gal	Lit	In	mm	In	mm	In	mm	In	mm	In	mm	Lbs	Kg
200-L	53	200	24	610	38	956	19	483	1	25	3/4	19	297	135
300-L	80	300	24	610	52	1308	19	483	1	25	3/4	19	372	169
400-L	106	400	24	610	66	1662	19	483	1	25	3/4	19	595	270
500-L	132	500	24	610	79	2006	19	483	1	25	3/4	19	750	340
600-L	158	600	30	762	64	1619	24	610	1 1/2	38	1	25	810	367
800-L	211	800	30	762	82	2076	24	610	1 1/2	38	1	25	950	431
1000-L	264	1000	36	914	74	1867	30	762	1 1/2	38	1 1/4	32	1065	483
1200-L	317	1200	36	914	86	2181	30	762	1 1/2	38	1 1/4	32	1235	560
1400-L	370	1400	36	914	98	2496	30	762	1 1/2	38	1 1/4	32	1400	635
1600-L	422	1600	48	1219	69	1756	42	1067	1 1/2	38	1 1/2	38	2015	914
2000-L	528	2000	48	1219	84	2145	42	1067	1 1/2	38	1 1/2	38	2651	1202
2500-L	660	2500	48	1219	101	2562	42	1067	2	50	1 1/2	38	2715	1232
3000-L	792	3000	48	1219	118	3000	42	1067	2	50	1 1/2	38	3100	1406
3500-L	925	3500	54	1372	111	2820	42	1067	2	50	1 1/2	38	3780	1715
4000-L	1057	4000	54	1372	125	3175	42	1067	2	50	1 1/2	38	4285	1944
5000-L	1321	5000	60	1524	128	3251	42	1067	2	50	1 1/2	38	5200	2359
7500-L	1980	7500	72	1829	127	3226	54	1372	3	76	1 1/2	38	6750	3062
7500-LCAN	1980	7500	72	1829	144	3658	54	1372	3	76	1 1/2	38	6750	3062
10000-L	2640	10000	72	1829	159	4039	54	1372	3	76	1 1/2	38	11000	4990
15000-L	3963	15000	72	1829	233	5918	54	1372	3	76	1 1/2	38	12500	5670

Optional Seismic Restraints

Tank Diameter	Bolt Circle	Dim. E	Dim. F	Hole Size
B	D	E	F	G
24	21	2	2	9/16
30	28	4	4	7/8
36	34	4	4	7/8
48	46	4	4	7/8
54	46	4	4	7/8
60	46	4	4	7/8
72	58	4	4	1

All dimensions and weights are approximate.

Job Name _____	Notes _____
Engineer _____	_____
Contractor _____	_____
P.O. No. _____	_____
Sales Rep. _____	_____
Model No. _____	_____





125 PSIG Working Pressure

Construction

Shell	ASME Approved Steel
Bladder Design	Partial Acceptance; Replaceable
Bladder Thickness (models 35-100)	.087 In Minimum
Bladder Thickness (models 130-600)	.100 In Minimum
System Connection	NPTF Malleable Iron
Finish	Red Oxide Primer
Air Valve	Schrader Valve w/EPDM Seats
Factory Precharge	12 PSIG (.8 bar)

Performance

Maximum Operating Temperature	240°F (115°C)
Maximum Working Pressure	125 PSIG (8.6 bar)
Warranty	3-Years

Application

- For use in closed, non-potable hydronic heating and chilled water systems.
- Replaceable, partial acceptance bladder design.
- Meets all ASME Code Section VIII, Division 1 standards.
- Available with optional sight glass and seismic restraints.
- Suitable in propylene glycol applications with mixtures up to 50%.

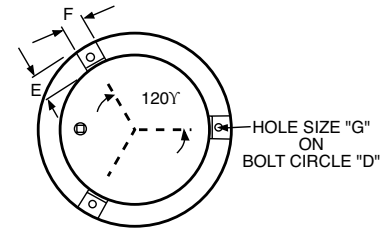
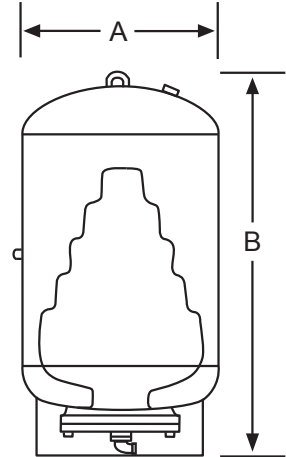

BOTTOM VIEW

ASME Models

Model Number	Tank Volume		Max. Accept. Factor	A Tank Diameter		B Tank Height		System Conn. (NPTF)	Shipping Weight	
	Gal	Lit		In	mm	Inch	mm		Lbs	Kg
35LBC	10	35	1.00	10	254	37	940	1	67	30
50LBC	13	50	.85	12	305	37	940	1	76	34
85LBC	22	85	.50	16	406	35	889	1	92	42
100LBC	26	100	.42	16	406	39	991	1	99	45
130LBC	34	130	.79	20	508	35	889	1	135	61
165LBC	44	165	.61	20	508	40	1016	1	149	68
200LBC	53	200	.51	24	610	41	1041	1	195	88
300LBC	80	300	.34	24	610	56	1422	1	233	106
400LBC	106	400	.50	24	610	69	1753	1	274	124
500LBC	132	500	.40	24	610	83	2108	1	310	141
600LBC	158	600	.34	30	762	67	1702	1	438	199

Optional Seismic Restraints

Tank Diameter	Bolt Circle	Dim. E	Dim. F	Hole Size
B	D	E	F	G
10	12 ⁵ / ₈	2	2	9 ¹ / ₁₆
12	14 ³ / ₄	2	2	9 ¹ / ₁₆
16	16 ³ / ₄	2	2	9 ¹ / ₁₆
20	16 ³ / ₄	2	2	9 ¹ / ₁₆
24	18	2	2	9 ¹ / ₁₆
30	24	4	4	7 ¹ / ₈

All dimensions and weights are approximate.

Job Name _____	Notes _____
Engineer _____	_____
Contractor _____	_____
P.O. No. _____	_____
Sales Rep. _____	_____
Model No. _____	_____





EXTROL®

Hydronic Expansion Tanks: LBC Series ASME

150 PSIG Working Pressure

Construction

Shell	ASME Approved Steel
Bladder Design	Partial Acceptance; Replaceable
Bladder Thickness (models 35-100)	.087 In Minimum
Bladder Thickness (models 130-600)	.100 In Minimum
System Connection	NPTF Malleable Iron
Finish	Red Oxide Primer
Air Valve	Schrader Valve w/EPDM Seats
Factory Precharge	12 PSIG (.8 bar)

Performance

Maximum Operating Temperature	240°F (115°C)
Maximum Working Pressure	150 PSIG (10.3 bar)
Warranty	3-Years

Application

- For use in closed, non-potable hydronic heating and chilled water systems.
- Replaceable, partial acceptance bladder design.
- Meets all ASME Code Section VIII, Division 1 standards.
- Available with optional sight glass and seismic restraints.
- Suitable in propylene glycol applications with mixtures up to 50%.

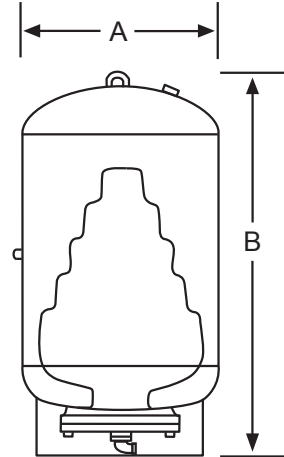

ASME Models

Model Number	Tank Volume		Max. Accept. Factor	A Tank Diameter		B Tank Height		System Conn. (NPTF)	Shipping Weight	
	Gal	Lit		In	mm	Inch	mm		Lbs	Kg
35LBC	10	35	1.00	10	254	37	940	1	76	34
50LBC	13	50	.85	12	305	37	940	1	78	35
85LBC	22	85	.50	16	406	35	889	1	95	43
100LBC	26	100	.42	16	406	39	991	1	102	46
130LBC	34	130	.79	20	508	35	889	1	140	64
165LBC	44	165	.61	20	508	40	1016	1	153	69
200LBC	53	200	.51	24	610	41	1041	1	205	93
300LBC	80	300	.34	24	610	56	1422	1	254	115
400LBC	106	400	.50	24	610	69	1753	1	308	140
500LBC	132	500	.40	24	610	83	2108	1	352	160
600LBC	158	600	.34	30	762	67	1702	1	442	200

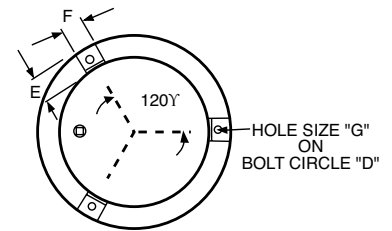

BOTTOM VIEW

Optional Seismic Restraints

Tank Diameter	Bolt Circle	Dim. E	Dim. F	Hole Size G
B	D	E	F	G
10	12 ⁵ / ₈	2	2	⁹ / ₁₆
12	14 ³ / ₄	2	2	⁹ / ₁₆
16	16 ³ / ₄	2	2	⁹ / ₁₆
20	16 ³ / ₄	2	2	⁹ / ₁₆
24	18	2	2	⁹ / ₁₆
30	24	3	3	³ / ₄

All dimensions and weights are approximate.

Job Name _____	Notes _____
Engineer _____	_____
Contractor _____	_____
P.O. No. _____	_____
Sales Rep. _____	_____
Model No. _____	_____





175 PSIG Working Pressure

Construction

Shell	ASME Approved Steel
Bladder Design	Partial Acceptance; Replaceable
Bladder Thickness (models 35-100)	.087 In Minimum
Bladder Thickness (models 130-600)	.100 In Minimum
System Connection	NPTF Malleable Iron
Finish	Red Oxide Primer
Air Valve	Schrader Valve w/EPDM Seats
Factory Precharge	12 PSIG (.8 bar)

Performance

Maximum Operating Temperature	240°F (115°C)
Maximum Working Pressure	175 PSIG (12 bar)
Warranty	3-Years

Application

- For use in closed, non-potable hydronic heating and chilled water systems.
- Replaceable, partial acceptance bladder design.
- Meets all ASME Code Section VIII, Division 1 standards.
- Available with optional sight glass and seismic restraints.
- Suitable in propylene glycol applications with mixtures up to 50%.

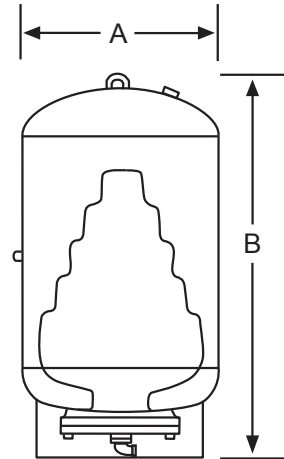

ASME Models

Model Number	Tank Volume		Max. Accept. Factor	A Tank Diameter		B Tank Height		System Conn. (NPTF)	Shipping Weight	
	Gal	Lit		In	mm	Inch	mm		Lbs	Kg
35LBC	10	35	1.00	10	254	37	940	1	80	36
50LBC	13	50	.85	12	305	37	940	1	91	41
85LBC	22	85	.50	16	406	35	889	1	110	50
100LBC	26	100	.42	16	406	39	991	1	119	54
130LBC	34	130	.79	20	508	35	889	1	162	73
165LBC	44	165	.61	20	508	40	1016	1	178	81
200LBC	53	200	.51	24	610	41	1041	1	234	106
300LBC	80	300	.34	24	610	56	1422	1	280	127
400LBC	106	400	.50	24	610	69	1753	1	329	149
500LBC	132	500	.40	24	610	83	2108	1	372	169
600LBC	158	600	.34	30	762	67	1702	1	525	238

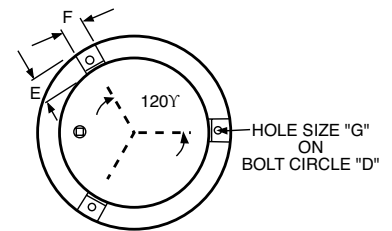

BOTTOM VIEW

Optional Seismic Restraints

Tank Diameter	Bolt Circle	Dim. E	Dim. F	Hole Size
B	D	E	F	G
10	12 ⁵ / ₈	2	2	⁹ / ₁₆
12	14 ³ / ₄	2	2	⁹ / ₁₆
16	16 ³ / ₄	2	2	⁹ / ₁₆
20	16 ³ / ₄	2	2	⁹ / ₁₆
24	18	2	2	⁹ / ₁₆
30	24	4	4	⁷ / ₈

All dimensions and weights are approximate.

Job Name _____	Notes _____
Engineer _____	_____
Contractor _____	_____
P.O. No. _____	_____
Sales Rep. _____	_____
Model No. _____	_____





EXTROL®

Hydronic Expansion Tanks: LBC Series ASME

250 PSIG Working Pressure

Construction

Shell	ASME Approved Steel
Bladder Design	Partial Acceptance; Replaceable
Bladder Thickness (models 35-100)	.087 In Minimum
Bladder Thickness (models 130-600)	.100 In Minimum
System Connection	NPTF Malleable Iron
Finish	Red Oxide Primer
Air Valve	Schrader Valve w/EPDM Seats
Factory Precharge	12 PSIG (.8 bar)

Performance

Maximum Operating Temperature	240°F (115°C)
Maximum Working Pressure	250 PSIG (17.2 bar)
Warranty	3-Years

Application

- For use in closed, non-potable hydronic heating and chilled water systems.
- Replaceable, partial acceptance bladder design.
- Meets all ASME Code Section VIII, Division 1 standards.
- Available with optional sight glass and seismic restraints.
- Suitable in propylene glycol applications with mixtures up to 50%.

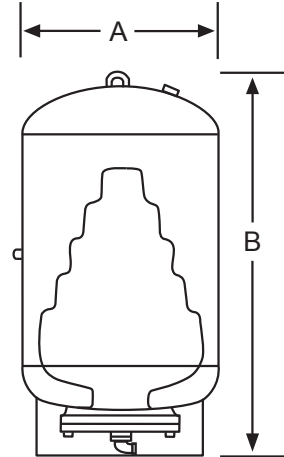

ASME Models

Model Number	Tank Volume		Max. Accept. Factor	A Tank Diameter		B Tank Height		System Conn. (NPTF)	Shipping Weight	
	Gal	Lit		In	mm	Inch	mm		Lbs	Kg
35LBC	10	35	1.00	10	254	37	940	1	94	43
50LBC	13	50	.85	12	305	37	940	1	106	48
85LBC	22	85	.50	16	406	35	889	1	129	59
100LBC	26	100	.42	16	406	39	991	1	138	63
130LBC	34	130	.79	20	508	35	889	1	189	86
165LBC	44	165	.61	20	508	40	1016	1	214	97
200LBC	53	200	.51	24	610	41	1041	1	273	124
300LBC	80	300	.34	24	610	56	1422	1	326	148
400LBC	106	400	.50	24	610	69	1753	1	383	174
500LBC	132	500	.40	24	610	83	2108	1	434	197
600LBC	158	600	.34	30	762	67	1702	1	613	278

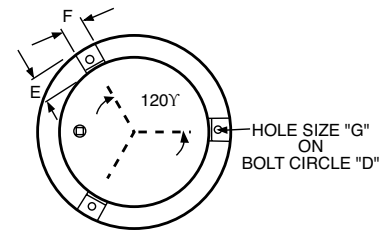

BOTTOM VIEW

Optional Seismic Restraints

Tank Diameter	Bolt Circle	Dim. E	Dim. F	Hole Size
B	D	E	F	G
10	12 ⁵ / ₈	2	2	9 ¹ / ₁₆
12	14 ³ / ₄	2	2	9 ¹ / ₁₆
16	16 ³ / ₄	2	2	9 ¹ / ₁₆
20	16 ³ / ₄	2	2	9 ¹ / ₁₆
24	18	2	2	9 ¹ / ₁₆
30	24	4	4	7 ⁸ / ₁₆

All dimensions and weights are approximate.

Job Name _____	Notes _____
Engineer _____	_____
Contractor _____	_____
P.O. No. _____	_____
Sales Rep. _____	_____
Model No. _____	_____





EXTROL®

Hydronic Expansion Tanks: LBC Series ASME

300 PSIG Working Pressure

Construction

Shell	ASME Approved Steel
Bladder Design	Partial Acceptance; Replaceable
Bladder Thickness (models 35-100)	.087 In Minimum
Bladder Thickness (models 130-600)	.100 In Minimum
System Connection	NPTF Malleable Iron
Finish	Red Oxide Primer
Air Valve	Schrader Valve w/EPDM Seats
Factory Precharge	12 PSIG (.8 bar)

Performance

Maximum Operating Temperature	240°F (115°C)
Maximum Working Pressure	300 PSIG (20.7 bar)
Warranty	3-Years

Application

- For use in closed, non-potable hydronic heating and chilled water systems.
- Replaceable, partial acceptance bladder design.
- Meets all ASME Code Section VIII, Division 1 standards.
- Available with optional sight glass and seismic restraints.
- Suitable in propylene glycol applications with mixtures up to 50%.

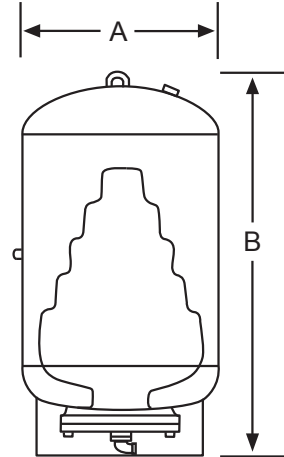

ASME Models

Model Number	Tank Volume		Max. Accept. Factor	A Tank Diameter		B Tank Height		System Conn. (NPTF)	Shipping Weight	
	Gal	Lit		In	mm	Inch	mm		In	Lbs
35LBC	10	35	1.00	10	254	37	940	1	100	45
50LBC	13	50	.85	12	305	37	940	1	114	52
85LBC	22	85	.50	16	406	35	889	1	138	63
100LBC	26	100	.42	16	406	39	991	1	150	68
130LBC	34	130	.79	20	508	35	889	1	202	92
165LBC	44	165	.61	20	508	40	1016	1	225	102
200LBC	53	200	.51	24	610	41	1041	1	293	133
300LBC	80	300	.34	24	610	56	1422	1	350	159
400LBC	106	400	.50	24	610	69	1753	1	411	186
500LBC	132	500	.40	24	610	83	2108	1	465	211
600LBC	158	600	.34	30	762	67	1702	1	657	298

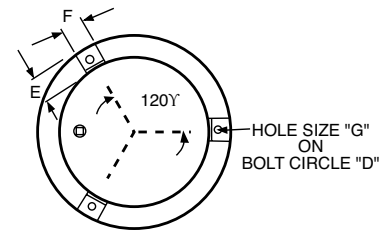

BOTTOM VIEW

Optional Seismic Restraints

Tank Diameter	Bolt Circle	Dim. E	Dim. F	Hole Size
B	D	E	F	G
10	12 ⁵ / ₈	2	2	⁹ / ₁₆
12	14 ³ / ₄	2	2	⁹ / ₁₆
16	16 ³ / ₄	2	2	⁹ / ₁₆
20	16 ³ / ₄	2	2	⁹ / ₁₆
24	18	2	2	⁹ / ₁₆
30	24	4	4	⁷ / ₈

All dimensions and weights are approximate.

Job Name _____	Notes _____
Engineer _____	_____
Contractor _____	_____
P.O. No. _____	_____
Sales Rep. _____	_____
Model No. _____	_____





AIR SEPARATOR

In-Line Purger: 1" - 3"

125 PSIG Working Pressure

Construction

Body	Cast Iron
------	-----------

Performance

Maximum Working Pressure	125 PSIG (8.6 bar)
Warranty	1-Year

Application

- Separates air from water in closed loop hydronic heating systems.
- System connection sets the point of no pressure change.
- Use with 700 Series Automatic Air Vents and Extrol® Expansion Tanks.

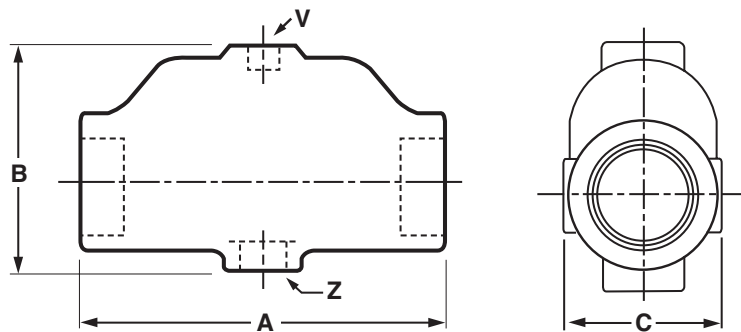

In-Line Models

Model Number	Connection		A Length		B Height		C Width		V Tapping NPT		Z Tapping NPT		Shipping Weight	
	In	mm	In	mm	In	mm	In	mm	In	mm	In	mm	Lbs	Kg
443	1	25	6	152	4	102	2½	64	⅛	3	½	13	4	2
444	1¼	32	6	152	4	102	2½	64	⅛	3	½	13	5	2
445	1½	38	8	203	5	127	3½	89	⅛	3	½	13	9	4
446	2	51	8	203	5	127	3½	89	½	13	½	13	10	5
447	2½	64	10	254	6	152	5	127	¾	19	½	13	19	9
448	3	76	10	254	6	152	5	127	¾	19	½	13	20	9

All dimensions and weights are approximate.

Job Name _____	Notes _____
Engineer _____	_____
Contractor _____	_____
P.O. No. _____	_____
Sales Rep. _____	_____
Model No. _____	_____





AIR SEPARATOR

In-Line Purger: 4" - 18"

125/150 PSIG Working Pressure

Construction

Body	449: Cast Iron
	461 - 468: Steel
Connection	449 - 466: 150 Lb ANSI Flanges
	467 & 468: Butt Weld Ends
	Larger sizes available upon request.

Performance

Max Working Pressure	449: 125 PSIG (8.6 bar)
	461 - 468: 150 PSIG (10.3 bar)
Warranty	1-Year

Application

- Separates air from water in closed hydronic and chilled water systems.
- Unique baffle design moves air into domed cavity above which an air vent can be mounted.
- Use with 747 High Capacity Air Vent.

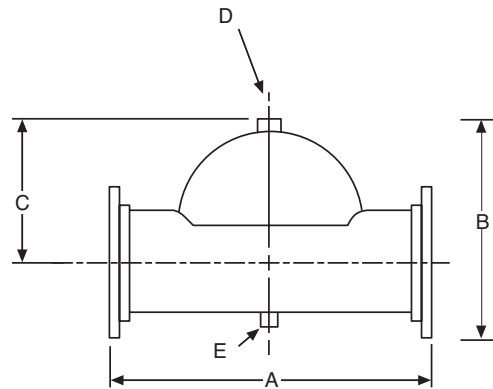

In-Line Models

Model Number	Connection		A Length		B Height		C Conn. to Top		D Vent Tappings NPT		E Drain Tappings NPT		Shipping Weight	
	In	mm	In	mm	In	mm	In	mm	In	mm	In	mm	Lbs	Kg
449	4	102	12	305	10	254	5	127	¼	19	½	13	56	25
461	5	127	20	508	14½	368	8	191	1¼	38	1½	38	60	27
462	6	152	24	610	16½	419	9	216	1¼	32	1½	38	65	29
463	8	203	32	813	20¾	527	11	286	1¼	32	1½	38	113	51
464	10	254	40	1016	25	635	14	356	1¼	32	1½	38	174	79
465	12	305	48	1219	29½	749	17	425	1¼	32	1½	38	330	150
466	14	356	48	1219	34	864	19	492	1¼	32	1½	38	500	227
467	16	406	48	1219	32¼	819	20	508	1¼	32	1½	38	231	150
468	18	457	72	1829	37¼	946	24	597	1¼	32	1½	38	573	260

All dimensions and weights are approximate.

Job Name _____	Notes _____
Engineer _____	_____
Contractor _____	_____
P.O. No. _____	_____
Sales Rep. _____	_____
Model No. _____	_____





AIR SEPARATOR

Tangential Air Separators: 2" - 24" with Strainer ASME

Flow/Pressure Drop Chart

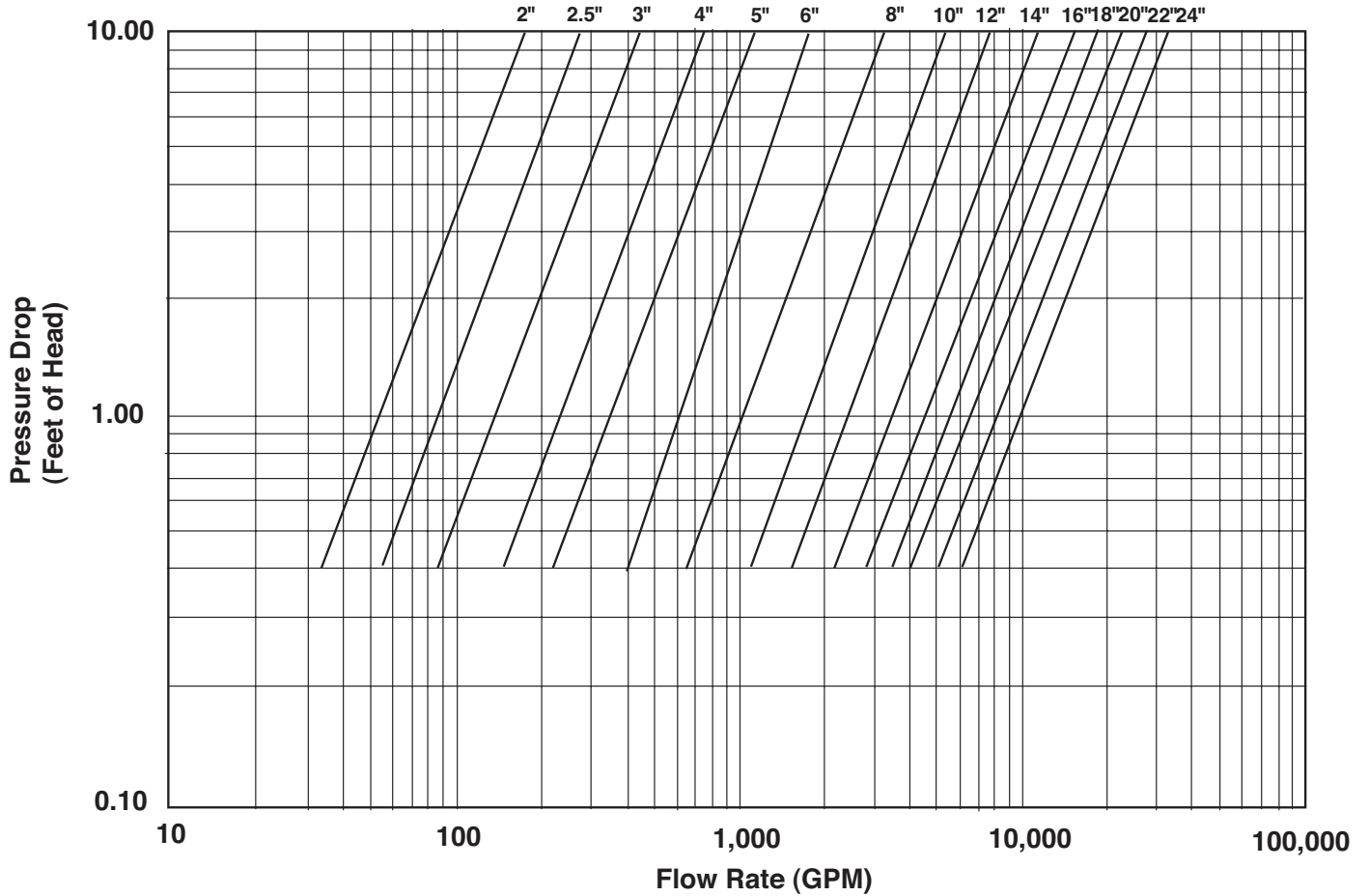

Indicates pressure drop in feet of water versus flow in gallons per minute with strainer. This is an improved method for properly computing pressure drop in AMTROL Air Separators.

All calculations are approximate.

Job Name _____	Notes _____
Engineer _____	_____
Contractor _____	_____
P.O. No. _____	_____
Sales Rep. _____	_____
Model No. _____	_____





AIR SEPARATOR

Tangential Air Separators: 1" - 24" without Strainer ASME

Flow/Pressure Drop Chart

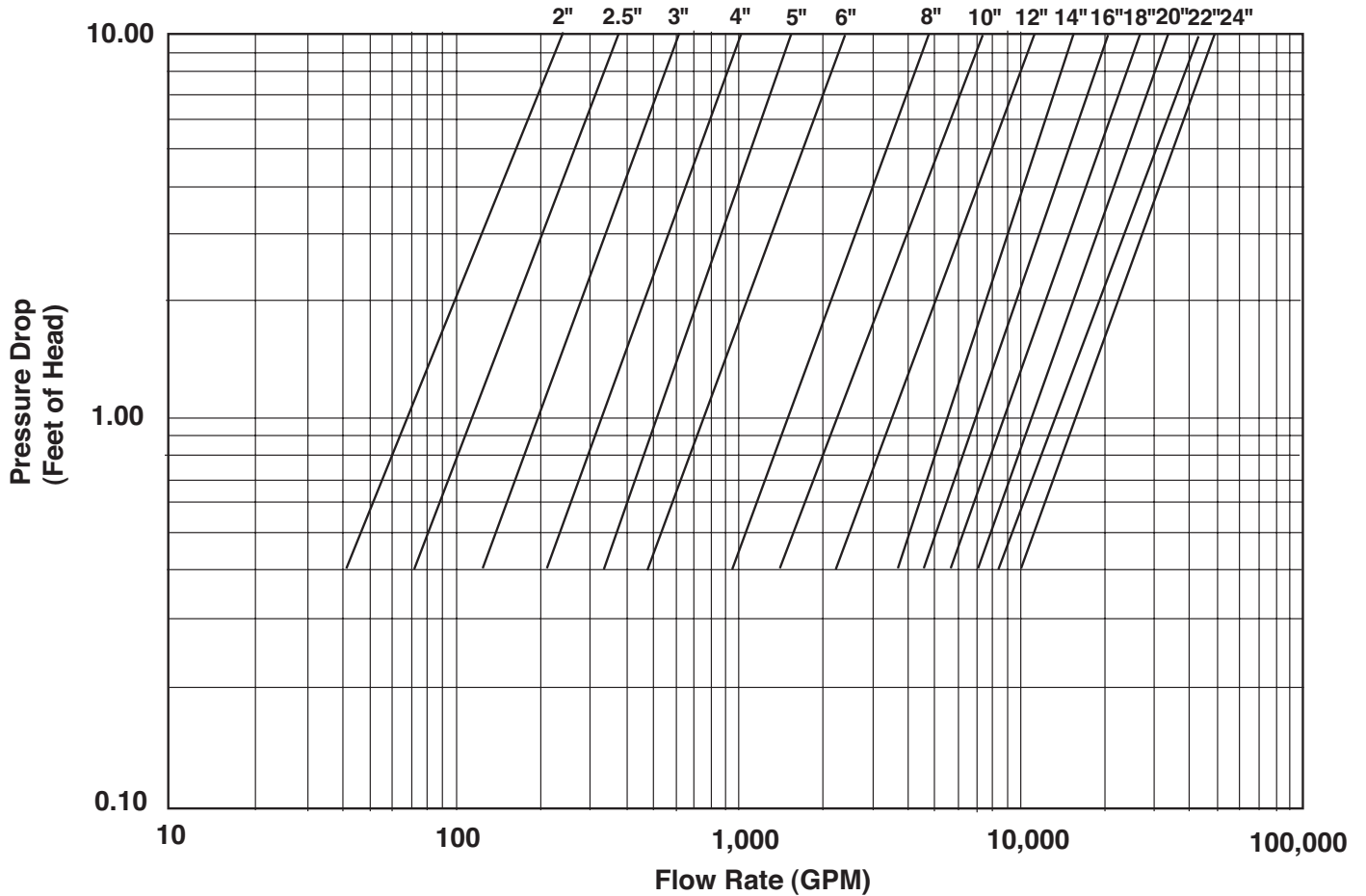

Indicates pressure drop in feet of water versus flow in gallons per minute without strainer. This is an improved method for properly computing pressure drop in AMTROL Air Separators.

All calculations are approximate.

Job Name _____	Notes _____
Engineer _____	_____
Contractor _____	_____
P.O. No. _____	_____
Sales Rep. _____	_____
Model No. _____	_____





AIR SEPARATOR

Tangential Air Separators: 2" - 24" with Strainer ASME

125 PSIG Working Pressure

Construction

Body	ASME Approved Steel
Flanges	ASME Class 150
Removable Strainer	304 Stainless Steel

Performance

Maximum Operating Temperature	350°F (176.7°C)
Maximum Working Pressure	125 PSIG (8.6 bar)
Warranty	3-Years

Application

- Creates a low velocity vortex that separates and removes entrained air from circulating water or anti-freeze.

- For use in closed, non-potable water systems.
- Designed and constructed per ASME Code Section VIII, Division 1.

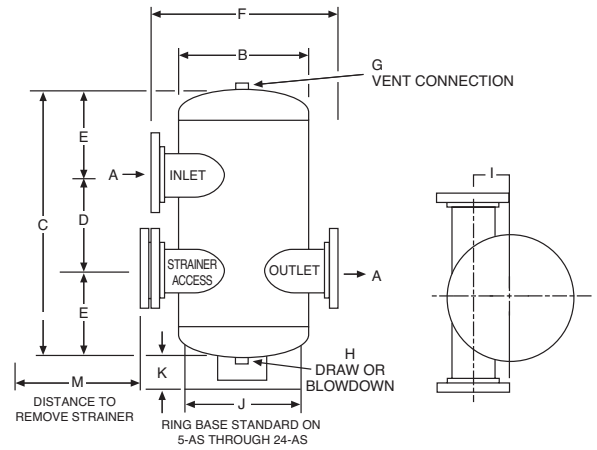

ASME Models

Model Number	Dimensions												Sq In	Shipping Weight		Clearance to Remove Strainer
	A	B	C	D	E	F	G	H	I	J	K	M	Strainer Screen Free Area	Lbs	Kg	In
	In	In	In	In	In	In	In	In	In	In	In	In				
2-AS	2	10	23	8	7½	17	¾	¾	3	-	-	14	33	45	20	12
2½-AS	2½	10	23	8	7½	17	¾	¾	3	-	-	14	40	54	24	13
3-AS	3	10	23	8	7½	17	¾	¾	3	-	-	14	45	60	27	15
4-AS	4	12	25	10	7½	21	¾	¾	3½	-	-	16½	78	70	32	17
5-AS	5	16	34½	12	11¼	24	¾	¾	4¼	12¾	4⅝	21½	120	200	91	22
6-AS	6	18	39	14	12½	26	¾	¾	4¼	14	4⅝	23	186	249	113	24
8-AS	8	24	52	18	17	32	¾	¾	5¼	16	4⅝	29	313	375	170	30
10-AS	10	30	59½	22	18¾	40	¾	¾	7¼	24	4⅝	35	491	750	340	36
12-AS	12	36	70	26	22	46	¾	¾	7¼	30	12⅝	40	644	950	431	45
14-AS	14	42	87	30	28½	56	¾	¾	13	30	13⅝	48	810	2200	998	49
16-AS	16	48	90	32	29	64	3	3	15	42	12½	56	969	3000	1361	59
18-AS	18	54	102	36	33	64	3	3	16	42	12⅝	62	1517	3500	1588	62
20-AS	20	60	100	30	35	70	3	3	19	45	6⅝	68	1860	5000	2268	70
22-AS	22	60	119	48	35½	70	3	3	18	45	7	68	2073	5500	2495	74
24-AS	24	72	136	43	46½	82	3	3	22	45	8	80	2712	7000	3175	80

All dimensions and weights are approximate.

Job Name _____	Notes _____
Engineer _____	_____
Contractor _____	_____
P.O. No. _____	_____
Sales Rep. _____	_____
Model No. _____	_____





AIR SEPARATOR

Tangential Air Separators: 2" - 24" with Strainer ASME

150 PSIG Working Pressure

Construction

Body	ASME Approved Steel
Flanges	ASME Class 150
Removable Strainer	304 Stainless Steel

Performance

Maximum Operating Temperature	350°F (176.7°C)
Maximum Working Pressure	150 PSIG (10.3 bar)
Warranty	3-Years

Application

- Creates a low velocity vortex that separates and removes entrained air from circulating water or anti-freeze.

- For use in closed, non-potable water systems.
- Designed and constructed per ASME Code Section VIII, Division 1.

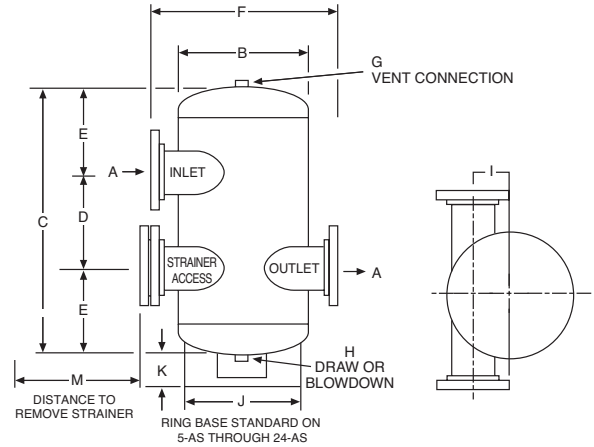

ASME Models

Model Number	Dimensions												Sq In	Shipping Weight		Clearance to Remove Strainer
	A	B	C	D	E	F	G	H	I	J	K	M	Strainer Screen Free Area	Lbs	Kg	In
	In	In	In	In	In	In	In	In	In	In	In	In				
2-AS	2	10	23	8	7½	17	¾	¾	3	-	-	14	33	47	21	12
2½-AS	2½	10	23	8	7½	17	¾	¾	3	-	-	14	40	58	26	13
3-AS	3	10	23	8	7½	17	¾	¾	3	-	-	14	45	64	29	15
4-AS	4	12	25	10	7½	21	¾	¾	3½	-	-	16½	78	83	38	17
5-AS	5	16	34½	12	11¼	24	¾	¾	4¼	12¾	4⅝	21½	120	220	100	22
6-AS	6	18	39	14	12½	26	¾	¾	4¼	14	4⅝	23	186	261	118	24
8-AS	8	24	52	18	17	32	¾	¾	5¼	16	4⅝	29	313	445	202	30
10-AS	10	30	59½	22	18¾	40	¾	¾	7¼	24	4⅝	35	491	800	363	36
12-AS	12	36	70	26	22	46	¾	¾	7¼	30	12⅝	40	644	1060	481	45
14-AS	14	42	87	30	28½	56	¾	¾	13	30	13⅜	48	810	2500	1134	49
16-AS	16	48	90	32	29	64	3	3	15	42	12½	56	969	3900	1769	59
18-AS	18	54	102	36	33	64	3	3	16	42	12⅝	62	1517	4700	2132	62
20-AS	20	60	100	30	35	70	3	3	19	45	6⅝	68	1860	6100	2767	70
22-AS	22	60	119	48	35½	70	3	3	18	45	7	68	2073	6600	2994	74
24-AS	24	72	136	43	46½	82	3	3	22	45	8	80	2712	8400	3810	80

All dimensions and weights are approximate.

Job Name _____	Notes _____
Engineer _____	_____
Contractor _____	_____
P.O. No. _____	_____
Sales Rep. _____	_____
Model No. _____	_____





AIR SEPARATOR

Tangential Air Separators: 2" - 24" with Strainer ASME

175 PSIG Working Pressure

Construction

Body	ASME Approved Steel
Flanges	ASME Class 150
Removable Strainer	304 Stainless Steel

Performance

Maximum Operating Temperature	350°F (176.7°C)
Maximum Working Pressure	175 PSIG (12 bar)
Warranty	3-Years

Application

- Creates a low velocity vortex that separates and removes entrained air from circulating water or anti-freeze.

- For use in closed, non-potable water systems.
- Designed and constructed per ASME Code Section VIII, Division 1.

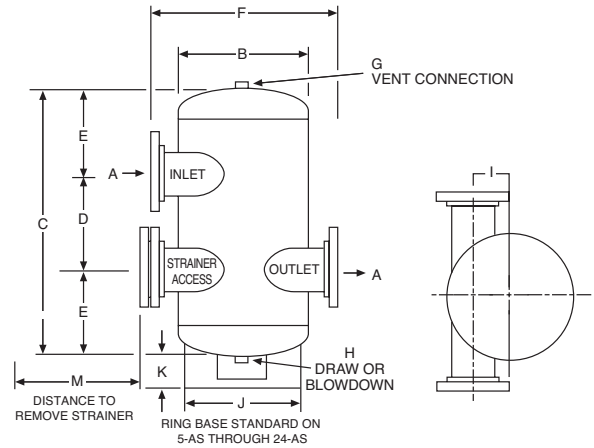

ASME Models

Model Number	Dimensions												Sq In Strainer Screen Free Area	Shipping Weight		Clearance to Remove Strainer In
	A	B	C	D	E	F	G	H	I	J	K	M		Lbs	Kg	
	In	In	In	In	In	In	In	In	In	In	In	In	In			
2-AS	2	10	23	8	7½	17	¾	¾	3	-	-	14	33	63	29	12
2½-AS	2½	10	23	8	7½	17	¾	¾	3	-	-	14	40	75	34	13
3-AS	3	10	23	8	7½	17	¾	¾	3	-	-	14	45	84	38	15
4-AS	4	12	25	10	7½	21	¾	¾	3½	-	-	16½	78	98	44	17
5-AS	5	16	34½	12	11¼	24	¾	¾	4¼	12¾	4⅝	21½	120	280	127	22
6-AS	6	18	39	14	12½	26	¾	¾	4¼	14	4⅝	23	186	348	158	24
8-AS	8	24	52	18	17	32	¾	¾	5¼	16	4⅝	29	313	525	238	30
10-AS	10	30	59½	22	18¾	40	¾	¾	7¼	24	4⅝	35	491	1050	476	36
12-AS	12	36	70	26	22	46	¾	¾	7¼	30	12⅝	40	644	1330	603	45
14-AS	14	42	87	30	28½	56	¾	¾	13	30	13⅜	48	810	3080	1397	49
16-AS	16	48	90	32	29	64	3	3	15	42	12½	56	969	4200	1905	59
18-AS	18	54	102	36	33	64	3	3	16	42	12⅝	62	1517	4900	2223	62
20-AS	20	60	100	30	35	70	3	3	19	45	6⅝	68	1860	7000	3175	70
22-AS	22	60	119	48	35½	70	3	3	18	45	7	68	2073	7700	3493	74
24-AS	24	72	136	43	46½	82	3	3	22	45	8	80	2712	9800	4445	80

All dimensions and weights are approximate.

Job Name _____	Notes _____
Engineer _____	_____
Contractor _____	_____
P.O. No. _____	_____
Sales Rep. _____	_____
Model No. _____	_____





AIR SEPARATOR

Tangential Air Separators: 2" - 24" with Strainer ASME

250 PSIG Working Pressure

Construction

Body	ASME Approved Steel
Flanges	ASME Class 300
Removable Strainer	304 Stainless Steel

Performance

Maximum Operating Temperature	350°F (176.7°C)
Maximum Working Pressure	250 PSIG (17.2 bar)
Warranty	3-Years

Application

- Creates a low velocity vortex that separates and removes entrained air from circulating water or anti-freeze.

- For use in closed, non-potable water systems.
- Designed and constructed per ASME Code Section VIII, Division 1.

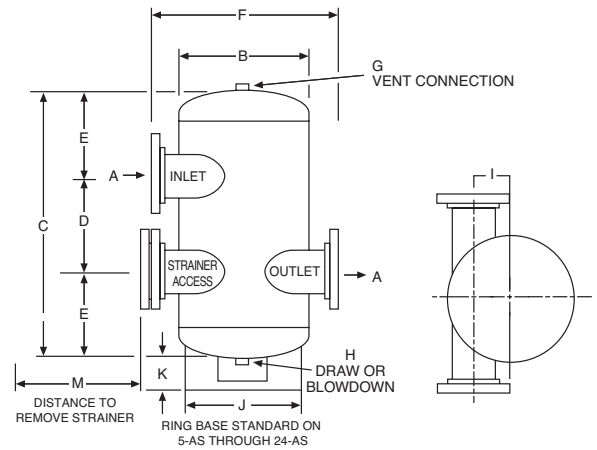

ASME Models

Model Number	Dimensions												Sq In Strainer Screen Free Area	Shipping Weight		Clearance to Remove Strainer In
	A	B	C	D	E	F	G	H	I	J	K	M		Lbs	Kg	
	In	In	In	In	In	In	In	In	In	In	In	In				
2-AS	2	10	23	8	7½	17	¾	¾	3	-	-	14	33	72	33	12
2½-AS	2½	10	23	8	7½	17	¾	¾	3	-	-	14	40	86	39	13
3-AS	3	10	23	8	7½	17	¾	¾	3	-	-	14	45	96	44	15
4-AS	4	12	25	10	7½	21	¾	¾	3½	-	-	16½	78	112	51	17
5-AS	5	16	34½	12	11¼	24	¾	¾	4¼	12¾	4⅝	21½	120	320	145	22
6-AS	6	18	39	14	12½	26	¾	¾	4¼	14	4⅝	23	186	398	181	24
8-AS	8	24	52	18	17	32	¾	¾	5¼	16	4⅝	29	313	600	272	30
10-AS	10	30	59½	22	18¾	40	¾	¾	7¼	24	4⅝	35	491	1200	544	36
12-AS	12	36	70	26	22	46	¾	¾	7¼	30	12⅝	40	644	1520	689	45
14-AS	14	42	87	30	28½	56	¾	¾	13	30	13⅝	48	810	3520	1597	49
16-AS	16	48	90	32	29	64	3	3	15	42	12½	56	969	4800	2177	59
18-AS	18	54	102	36	33	64	3	3	16	42	12⅝	62	1517	5600	2540	62
20-AS	20	60	100	30	35	70	3	3	19	45	6⅝	68	1860	8000	3629	70
22-AS	22	60	119	48	35½	70	3	3	18	45	7	68	2073	8800	3992	74
24-AS	24	72	136	43	46½	82	3	3	22	45	8	80	2712	11200	5080	80

All dimensions and weights are approximate.

Job Name _____	Notes _____
Engineer _____	_____
Contractor _____	_____
P.O. No. _____	_____
Sales Rep. _____	_____
Model No. _____	_____





AIR SEPARATOR

Tangential Air Separators: 2" - 24" with Strainer ASME

300 PSIG Working Pressure

Construction

Body	ASME Approved Steel
Flanges	ASME Class 300
Removable Strainer	304 Stainless Steel

Performance

Maximum Operating Temperature	350°F (176.7°C)
Maximum Working Pressure	300 PSIG (20.7 bar)
Warranty	3-Years

Application

- Creates a low velocity vortex that separates and removes entrained air from circulating water or anti-freeze.
- For use in closed, non-potable water systems.
- Designed and constructed per ASME Code Section VIII, Division 1.

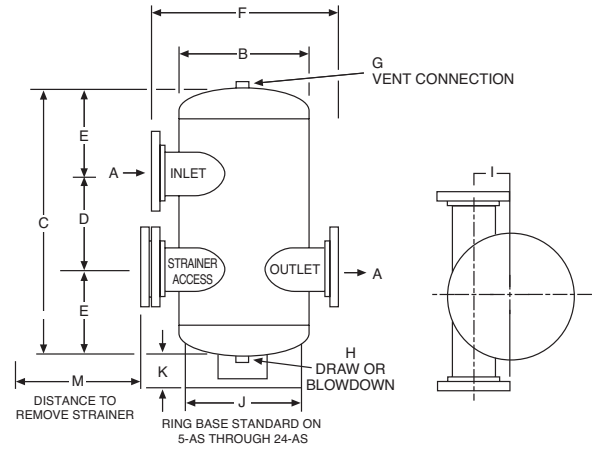

ASME Models

Model Number	Dimensions												Sq In	Shipping Weight		Clearance to Remove Strainer
	A	B	C	D	E	F	G	H	I	J	K	M	Strainer Screen Free Area	Lbs	Kg	In
	In	In	In	In	In	In	In	In	In	In	In	In				
2-AS	2	10	23	8	7½	17	¾	¾	3	-	-	14	33	81	37	12
2½-AS	2½	10	23	8	7½	17	¾	¾	3	-	-	14	40	97	44	13
3-AS	3	10	23	8	7½	17	¾	¾	3	-	-	14	45	108	49	15
4-AS	4	12	25	10	7½	21	¾	¾	3½	-	-	16½	78	126	57	17
5-AS	5	16	34½	12	11¼	24	¾	¾	4¼	12¾	4⅝	21½	120	360	163	22
6-AS	6	18	39	14	12½	26	¾	¾	4¼	14	4⅝	23	186	448	203	24
8-AS	8	24	52	18	17	32	¾	¾	5¼	16	4⅝	29	313	675	306	30
10-AS	10	30	59½	22	18¾	40	¾	¾	7¼	24	4⅝	35	491	1350	612	36
12-AS	12	36	70	26	22	46	¾	¾	7¼	30	12⅝	40	644	1710	776	45
14-AS	14	42	87	30	28½	56	¾	¾	13	30	13⅜	48	810	3960	1796	49
16-AS	16	48	90	32	29	64	3	3	15	42	12½	56	969	5400	2449	59
18-AS	18	54	102	36	33	64	3	3	16	42	12⅝	62	1517	6300	2858	62
20-AS	20	60	100	30	35	70	3	3	19	45	6⅝	68	1860	9000	4082	70
22-AS	22	60	119	48	35½	70	3	3	18	45	7	68	2073	9900	4491	74
24-AS	24	72	136	43	46½	82	3	3	22	45	8	80	2712	12600	5715	80

All dimensions and weights are approximate.

Job Name _____	Notes _____
Engineer _____	_____
Contractor _____	_____
P.O. No. _____	_____
Sales Rep. _____	_____
Model No. _____	_____





AIR SEPARATOR

Tangential Air Separators: 1" - 24" without Strainer ASME

125 PSIG Working Pressure

Construction

Body	ASME Approved Steel
Flanges	ASME Class 150

Performance

Maximum Operating Temperature	350°F (176.7°C)*
Maximum Working Pressure	125 PSIG (8.6 bar)
Warranty	3-Years

Application

- Creates a low velocity vortex that separates and removes entrained air from circulating water or anti-freeze.

- For use in closed, non-potable water systems.
- Designed and constructed per ASME Code Section VIII, Division 1.

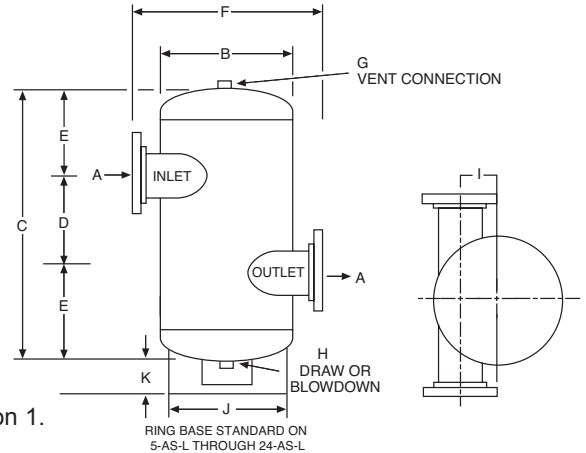

ASME Models

Model Number	Dimensions																				Shipping Weight			
	A		B		C		D		E		F		G		H		I		J		K		Lbs	Kg
	In	mm	In	mm	In	mm	In	mm	In	mm	In	mm	In	mm	In	mm	In	mm	In	mm	In	mm		
1-ASL*	1	25	4½	114	12	305	4	102	4	102	7	178	¾	19	¾	19	1⅞	33	-	-	-	-	14	6
2-ASL	2	51	10	254	23	584	8	203	7½	191	17	432	¾	19	¾	19	3	76	-	-	-	-	41	19
2½-ASL	2½	64	10	254	23	584	8	203	7½	191	17	432	¾	19	¾	19	3	76	-	-	-	-	50	23
3-ASL	3	76	10	254	23	584	8	203	7½	191	17	432	¾	19	¾	19	3	76	-	-	-	-	56	25
4-ASL	4	102	12	305	25	635	10	254	7½	191	21	533	¾	19	¾	19	3½	89	-	-	-	-	66	30
5-ASL	5	127	16	406	34½	876	12	305	11¼	286	24	610	¾	19	¾	19	4¼	108	12¼	324	4⅝	117	175	79
6-ASL	6	152	18	457	41	1041	14	356	13½	343	26	660	¾	19	¾	19	4¼	108	14	356	4⅝	117	190	86
8-ASL	8	203	24	610	52	1321	18	457	17	432	32	813	¾	19	¾	19	5¼	146	16	406	4⅝	117	350	159
10-ASL	10	254	30	762	58	1473	21	533	18½	470	40	1016	¾	19	¾	19	7¼	197	24	610	4⅝	117	700	318
12-ASL	12	305	36	914	68	1727	26	660	21	533	46	1168	¾	19	¾	19	7¼	197	30	762	12⅝	321	912	414
14-ASL	14	356	42	1067	87	2210	30	762	28½	724	56	1422	¾	19	¾	19	13	330	30	762	13⅝	340	1853	841
16-ASL	16	406	48	1219	90	2286	32	813	29	737	64	1626	3	76	3	76	15	381	42	1067	12½	318	2610	1184
18-ASL	18	457	54	1372	102	2591	36	914	33	838	64	1626	3	76	3	76	16	406	42	1067	12⅝	314	2900	1315
20-ASL	20	508	60	1524	100	2540	30	762	35	889	70	1778	3	76	3	76	19	483	45	1143	6⅞	176	4560	2068
22-ASL	22	559	60	1524	119	3023	48	1219	35½	902	70	1778	3	76	3	76	18	457	45	1143	7	178	5320	2413
24-ASL	24	610	72	1829	131	3327	43	1092	44	1118	82	2083	3	76	3	76	22	559	45	1143	8	203	6175	2801

*Only available with NPT connection.

All dimensions and weights are approximate.

Job Name _____	Notes _____
Engineer _____	_____
Contractor _____	_____
P.O. No. _____	_____
Sales Rep. _____	_____
Model No. _____	_____





AIR SEPARATOR

Tangential Air Separators: 1" - 24" without Strainer ASME

150 PSIG Working Pressure

Construction

Body	ASME Approved Steel
Flanges	ASME Class 150

Performance

Maximum Operating Temperature	350°F (176.7°C)
Maximum Working Pressure	150 PSIG (10.3 bar)
Warranty	3-Years

Application

- Creates a low velocity vortex that separates and removes entrained air from circulating water or anti-freeze.

- For use in closed, non-potable water systems.
- Designed and constructed per ASME Code Section VIII, Division 1.

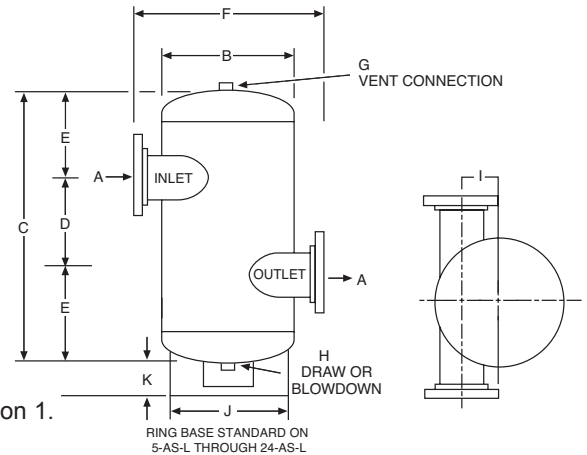

ASME Models

Model Number	Dimensions																				Shipping Weight			
	A		B		C		D		E		F		G		H		I		J		K		Lbs	Kg
	In	mm	In	mm	In	mm	In	mm	In	mm	In	mm	In	mm	In	mm	In	mm	In	mm	In	mm		
1-ASL*	1	25	4½	114	12	305	4	102	4	102	7	178	¾	19	¾	19	1⅞	33	-	-	-	-	15	7
2-ASL	2	51	10	254	23	584	8	203	7½	191	17	432	¾	19	¾	19	3	76	-	-	-	-	43	20
2½-ASL	2½	64	10	254	23	584	8	203	7½	191	17	432	¾	19	¾	19	3	76	-	-	-	-	54	24
3-ASL	3	76	10	254	23	584	8	203	7½	191	17	432	¾	19	¾	19	3	76	-	-	-	-	60	27
4-ASL	4	102	12	305	25	635	10	254	7½	191	21	533	¾	19	¾	19	3½	89	-	-	-	-	79	36
5-ASL	5	127	16	406	34½	876	12	305	11¼	286	24	610	¾	19	¾	19	4¼	108	12¾	324	4%	117	195	88
6-ASL	6	152	18	457	41	1041	14	356	13½	343	26	660	¾	19	¾	19	4¼	108	14	356	4%	117	210	95
8-ASL	8	203	24	610	52	1321	18	457	17	432	32	813	¾	19	¾	19	5¼	146	16	406	4%	117	400	181
10-ASL	10	254	30	762	58	1473	21	533	18½	470	40	1016	¾	19	¾	19	7¼	197	24	610	4%	117	750	340
12-ASL	12	305	36	914	68	1727	26	660	21	533	46	1168	¾	19	¾	19	7¼	197	30	762	12%	321	990	449
14-ASL	14	356	42	1067	87	2210	30	762	28½	724	56	1422	¾	19	¾	19	13	330	30	762	13%	340	2150	975
16-ASL	16	406	48	1219	90	2286	32	813	29	737	64	1626	3	76	3	76	15	381	42	1067	12½	318	3600	1633
18-ASL	18	457	54	1372	102	2591	36	914	33	838	64	1626	3	76	3	76	16	406	42	1067	12%	314	4000	1814
20-ASL	20	508	60	1524	100	2540	30	762	35	889	70	1778	3	76	3	76	19	483	45	1143	6%	176	5800	2631
22-ASL	22	559	60	1524	119	3023	48	1219	35½	902	70	1778	3	76	3	76	18	457	45	1143	7	178	6000	2722
24-ASL	24	610	72	1829	131	3327	43	1092	44	1118	82	2083	3	76	3	76	22	559	45	1143	8	203	7000	3175

*Only available with NPT connection.

All dimensions and weights are approximate.

Job Name _____	Notes _____
Engineer _____	_____
Contractor _____	_____
P.O. No. _____	_____
Sales Rep. _____	_____
Model No. _____	_____





AIR SEPARATOR

Tangential Air Separators: 2" - 24" without Strainer ASME

175 PSIG Working Pressure

Construction

Body	ASME Approved Steel
Flanges	ASME Class 150

Performance

Maximum Operating Temperature	350°F (176.7°C)
Maximum Working Pressure	175 PSIG (12 bar)
Warranty	3-Years

Application

- Creates a low velocity vortex that separates and removes entrained air from circulating water or anti-freeze.

- For use in closed, non-potable water systems.
- Designed and constructed per ASME Code Section VIII, Division 1.

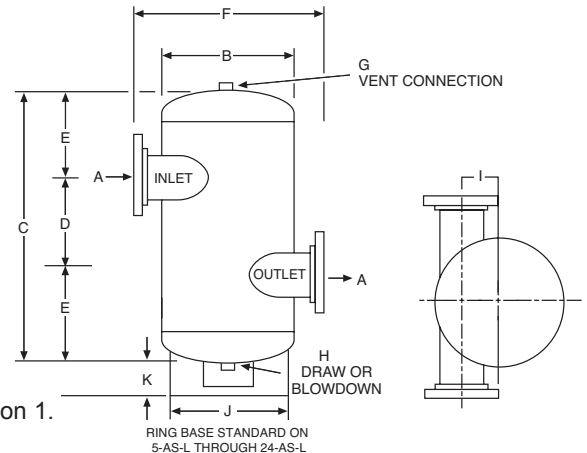

ASME Models

Model Number	Dimensions											Shipping Weight	
	A	B	C	D	E	F	G	H	I	J	K	Lbs	Kg
	In	In	In	In	In	In	In	In	In	In	In		
2-ASL	2	10	23	8	7½	17	¾	¾	3	-	-	59	27
2½-ASL	2½	10	23	8	7½	17	¾	¾	3	-	-	70	32
3-ASL	3	10	23	8	7½	17	¾	¾	3	-	-	80	36
4-ASL	4	12	25	10	7½	21	¾	¾	3½	-	-	92	42
5-ASL	5	16	34½	12	11¼	24	¾	¾	4¼	12¼	4⅝	266	121
6-ASL	6	18	41	14	13½	26	¾	¾	4¼	14	4⅝	330	150
8-ASL	8	24	52	18	17	32	¾	¾	5¼	16	4⅝	490	222
10-ASL	10	30	58	21	18½	40	¾	¾	7¼	24	4⅝	950	431
12-ASL	12	36	68	26	21	46	¾	¾	7¼	30	12⅝	1200	544
14-ASL	14	42	87	30	28½	56	¾	¾	13	30	13⅝	2800	1270
16-ASL	16	48	90	32	29	64	3	3	15	42	12½	4060	1842
18-ASL	18	54	102	36	33	64	3	3	16	42	12⅝	4600	2087
20-ASL	20	60	100	30	35	70	3	3	19	45	6⅝	6500	2948
22-ASL	22	60	119	48	35½	70	3	3	18	45	7	7000	3175
24-ASL	24	72	131	43	44	82	3	3	22	45	8	8500	3855

All dimensions and weights are approximate.

Job Name _____	Notes _____
Engineer _____	_____
Contractor _____	_____
P.O. No. _____	_____
Sales Rep. _____	_____
Model No. _____	_____





AIR SEPARATOR

Tangential Air Separators: 2" - 24" without Strainer ASME

250 PSIG Working Pressure

Construction

Body	ASME Approved Steel
Flanges	ASME Class 300

Performance

Maximum Operating Temperature	350°F (176.7°C)
Maximum Working Pressure	250 PSIG (17.2 bar)
Warranty	3-Years

Application

- Creates a low velocity vortex that separates and removes entrained water from circulating water or anti-freeze.

- For use in closed, non-potable water systems.
- Designed and constructed per ASME Code Section VIII, Division 1.

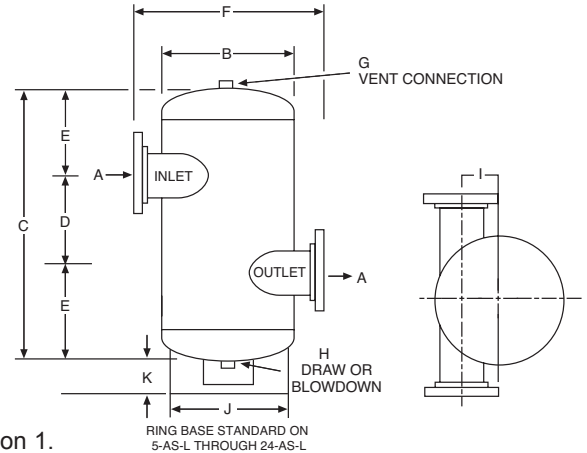

ASME Models

Model Number	Dimensions											Shipping Weight	
	A	B	C	D	E	F	G	H	I	J	K	Lbs	Kg
	In	In	In	In	In	In	In	In	In	In	In		
2-ASL	2	10	23	8	7½	17	¾	¾	3	-	-	65	29
2½-ASL	2½	10	23	8	7½	17	¾	¾	3	-	-	80	36
3-ASL	3	10	23	8	7½	17	¾	¾	3	-	-	90	41
4-ASL	4	12	25	10	7½	21	¾	¾	3½	-	-	105	48
5-ASL	5	16	34½	12	11¼	24	¾	¾	4¼	12¾	4⅝	280	127
6-ASL	6	18	41	14	13½	26	¾	¾	4¼	14	4⅝	350	159
8-ASL	8	24	52	18	17	32	¾	¾	5¾	16	4⅝	560	254
10-ASL	10	30	58	21	18½	40	¾	¾	7¼	24	4⅝	1120	508
12-ASL	12	36	68	26	21	46	¾	¾	7¼	30	12⅝	1460	662
14-ASL	14	42	87	30	28½	56	¾	¾	13	30	13⅝	2965	1345
16-ASL	16	48	90	32	29	64	3	3	15	42	12½	4175	1894
18-ASL	18	54	102	36	33	64	3	3	16	42	12⅝	5100	2313
20-ASL	20	60	100	30	35	70	3	3	19	45	6⅞	7300	3311
22-ASL	22	60	119	48	35½	70	3	3	18	45	7	8500	3856
24-ASL	24	72	131	43	44	82	3	3	22	45	8	9880	4481

All dimensions and weights are approximate.

Job Name _____	Notes _____
Engineer _____	_____
Contractor _____	_____
P.O. No. _____	_____
Sales Rep. _____	_____
Model No. _____	_____





AIR SEPARATOR

Tangential Air Separators: 2" - 24" without Strainer ASME

300 PSIG Working Pressure

Construction

Body	ASME Approved Steel
Flanges	ASME Class 300

Performance

Maximum Operating Temperature	350°F (176.7°C)
Maximum Working Pressure	300 PSIG (20.7 bar)
Warranty	3-Years

Application

- Creates a low velocity vortex that separates and removes entrained air from circulating water or anti-freeze.

- For use in closed, non-potable water systems.
- Designed and constructed per ASME Code Section VIII, Division 1.

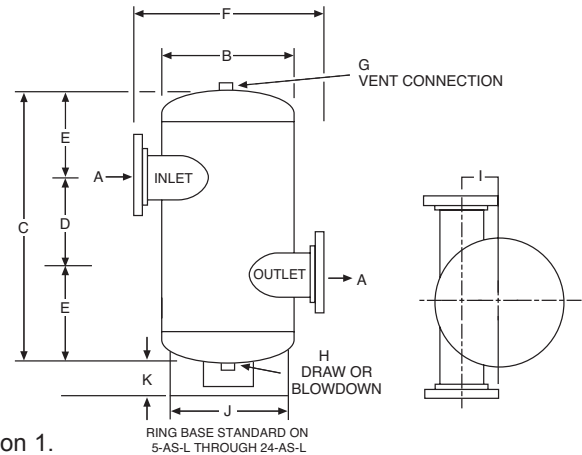

ASME Models

Model Number	Dimensions											Shipping Weight	
	A	B	C	D	E	F	G	H	I	J	K	Lbs	Kg
	In	In	In	In	In	In	In	In	In	In	In		
2-ASL	2	10	23	8	7½	17	¾	¾	3	-	-	74	34
2½-ASL	2½	10	23	8	7½	17	¾	¾	3	-	-	90	41
3-ASL	3	10	23	8	7½	17	¾	¾	3	-	-	100	45
4-ASL	4	12	25	10	7½	21	¾	¾	3½	-	-	118	54
5-ASL	5	16	34½	12	11¼	24	¾	¾	4¼	12¾	4⅝	315	143
6-ASL	6	18	41	14	13½	26	¾	¾	4¼	14	4⅝	400	181
8-ASL	8	24	52	18	17	32	¾	¾	5¾	16	4⅝	630	286
10-ASL	10	30	58	21	18½	40	¾	¾	7¾	24	4⅝	1260	572
12-ASL	12	36	68	26	21	46	¾	¾	7¾	30	12⅝	1640	744
14-ASL	14	42	87	30	28½	56	¾	¾	13	30	13⅝	3335	1513
16-ASL	16	48	90	32	29	64	3	3	15	42	12½	4700	2132
18-ASL	18	54	102	36	33	64	3	3	16	42	12⅝	5400	2450
20-ASL	20	60	100	30	35	70	3	3	19	45	6⅞	8200	3719
22-ASL	22	60	119	48	35½	70	3	3	18	45	7	9575	4343
24-ASL	24	72	131	43	44	82	3	3	22	45	8	11000	4990

All dimensions and weights are approximate.

Job Name _____	Notes _____
Engineer _____	_____
Contractor _____	_____
P.O. No. _____	_____
Sales Rep. _____	_____
Model No. _____	_____





AIR & DIRT SEPARATOR

Air Separators: 2" - 12"

125 PSIG Working Pressure

Construction

Body	ASME Approved Steel
Flanges	ASME Class 150

Performance

Maximum Operating Temperature	350°F (177°C)
Maximum Working Pressure	125 PSIG (8.6 bar)
Warranty	3-Years

Application

- Eliminates entrained air and separates debris associated with start-up and maintenance of any hydronic system.
- For use in closed, heating & chilled water systems.
- Magnetic separator option removes ferrous particles, includes dry well for ease of maintenance.
- Designed and constructed per ASME Code Section VIII, Division 1.

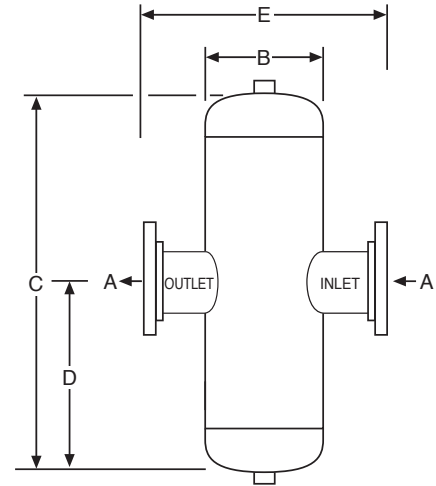

ASME Models

Model Number	Dimensions										Shipping Weight	
	A		B		C		D		E		Lbs	Kg
	In	mm	In	mm	In	mm	In	mm	In	mm		
2-ADS	2	51	6 $\frac{5}{8}$	168	22 $\frac{1}{2}$	572	11 $\frac{1}{4}$	286	15 $\frac{1}{4}$	387	60	27
3-ADS	3	76	8 $\frac{5}{8}$	219	28 $\frac{1}{2}$	724	14 $\frac{1}{4}$	362	20 $\frac{3}{4}$	514	92	42
4-ADS	4	102	8 $\frac{5}{8}$	219	28 $\frac{1}{2}$	724	14 $\frac{1}{4}$	362	20 $\frac{5}{8}$	524	102	46
5-ADS	5	127	12	305	42	1067	20 $\frac{3}{4}$	530	27 $\frac{3}{4}$	705	144	65
6-ADS	6	152	12	305	42 $\frac{1}{8}$	1070	21 $\frac{1}{8}$	537	27 $\frac{3}{4}$	705	149	68
8-ADS	8	203	16	406	49	1245	24 $\frac{1}{2}$	622	33 $\frac{5}{8}$	854	258	117
10-ADS	10	254	18	457	64	1626	32	813	37 $\frac{1}{2}$	953	384	174
12-ADS	12	305	24	610	75	1905	37 $\frac{1}{2}$	953	42 $\frac{1}{2}$	1080	533	242

2" NPT connections for air vent and blowdown assembly.
 Magnetic option adds 5 in. (127 mm) height and 12 lbs. (5 kg) shipping weight.
 All dimensions and weights are approximate.

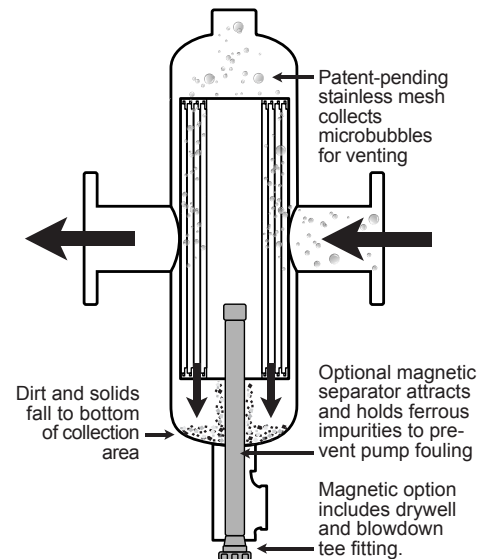

Job Name _____	Notes _____
Engineer _____	_____
Contractor _____	_____
P.O. No. _____	_____
Sales Rep. _____	_____
Model No. _____	_____





AIR & DIRT SEPARATOR

Air Separators: 2" - 12"

150 PSIG Working Pressure

Construction

Body	ASME Approved Steel
Flanges	ASME Class 150

Performance

Maximum Operating Temperature	350°F (177°C)
Maximum Working Pressure	150 PSIG (10.3 bar)
Warranty	3-Years

Application

- Eliminates entrained air and separates debris associated with start-up and maintenance of any hydronic system.
- For use in closed, heating & chilled water systems.
- Magnetic separator option removes ferrous particles, includes dry well for ease of maintenance.
- Designed and constructed per ASME Code Section VIII, Division 1.

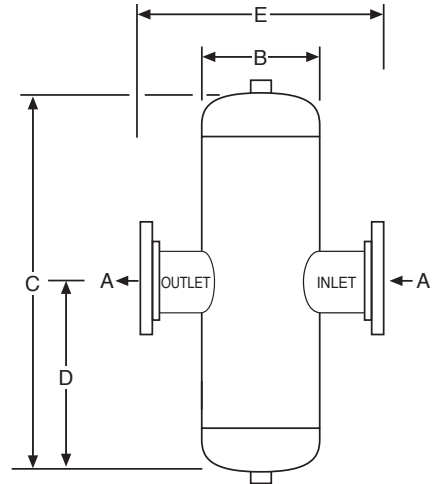

ASME Models

Model Number	Dimensions										Shipping Weight	
	A		B		C		D		E		Lbs	Kg
	In	mm	In	mm	In	mm	In	mm	In	mm		
2-ADS	2	51	6 $\frac{5}{8}$	168	22 $\frac{1}{2}$	572	11 $\frac{1}{4}$	286	15 $\frac{1}{4}$	387	65	29
3-ADS	3	76	8 $\frac{5}{8}$	219	28 $\frac{1}{2}$	724	14 $\frac{1}{4}$	362	20 $\frac{1}{4}$	514	97	44
4-ADS	4	102	8 $\frac{5}{8}$	219	28 $\frac{1}{2}$	724	14 $\frac{1}{4}$	362	20 $\frac{5}{8}$	524	110	50
5-ADS	5	127	12	305	42	1067	20 $\frac{3}{8}$	530	27 $\frac{3}{4}$	705	154	70
6-ADS	6	152	12	305	42 $\frac{1}{8}$	1070	21 $\frac{1}{8}$	537	27 $\frac{3}{4}$	705	159	72
8-ADS	8	203	16	406	49	1245	24 $\frac{1}{2}$	622	33 $\frac{5}{8}$	854	270	122
10-ADS	10	254	18	457	64	1626	32	813	37 $\frac{1}{2}$	953	395	179
12-ADS	12	305	24	610	75	1905	37 $\frac{1}{2}$	953	42 $\frac{1}{2}$	1080	550	249

2" NPT connections for air vent and blowdown assembly.
 Magnetic option adds 5 in. (127 mm) height and 12 lbs. (5 kg) shipping weight.
 All dimensions and weights are approximate.

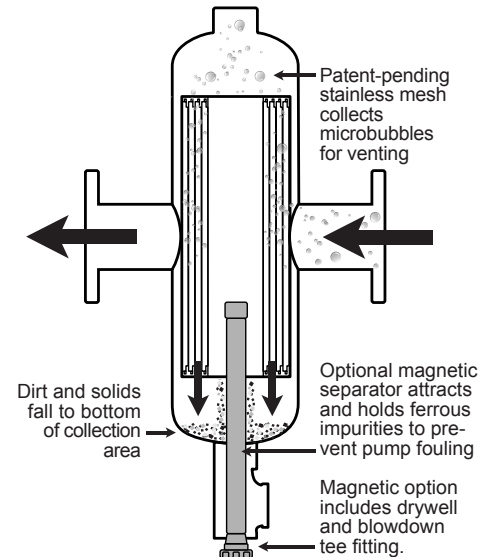

Job Name _____	Notes _____
Engineer _____	_____
Contractor _____	_____
P.O. No. _____	_____
Sales Rep. _____	_____
Model No. _____	_____





AIR & DIRT SEPARATOR

Separators: 2" - 12"

Flow/Pressure Drop Chart

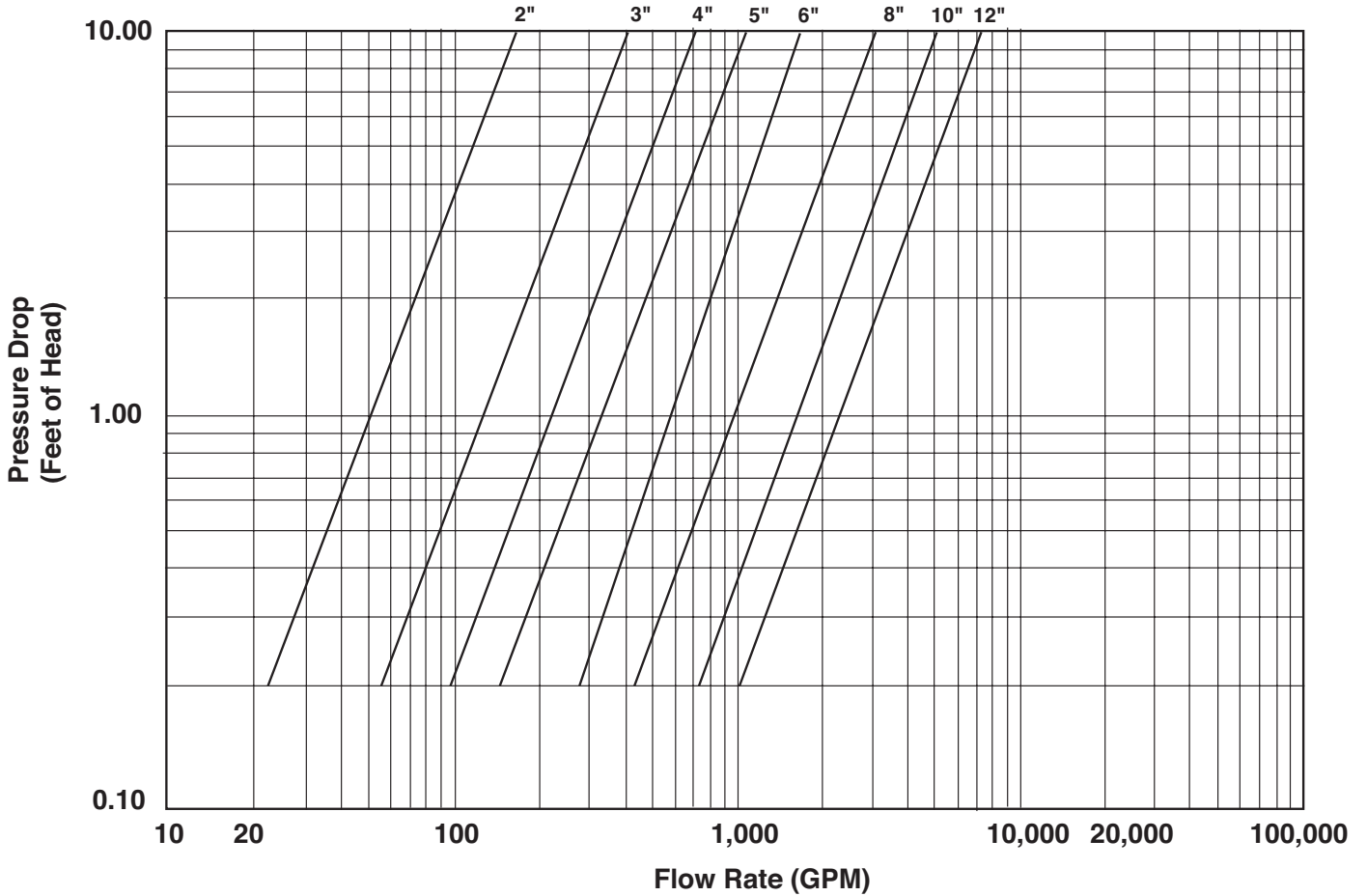

Indicates pressure drop in feet of water versus flow in gallons per minute. This is an improved method for properly computing pressure drop in AMTROL Separators.

All calculations are approximate.

Job Name _____	Notes _____
Engineer _____	_____
Contractor _____	_____
P.O. No. _____	_____
Sales Rep. _____	_____
Model No. _____	_____





AIR ELIMINATION EQUIPMENT

747 High Capacity Air Vent

150 PSIG Working Pressure

Construction

Material	Cast Iron with stainless steel, brass and EPDM internal components
----------	--

Application

- High capacity float-type air vent.
- For use in closed loop heating or chill water systems.

Performance

Maximum Operating Temperature	250°F (121°C)*
Maximum Working Pressure	150 PSIG (10.5 bar)
Warranty	3-Years

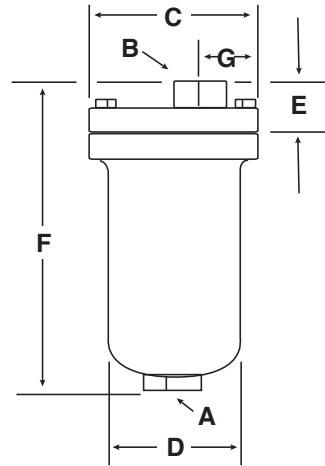
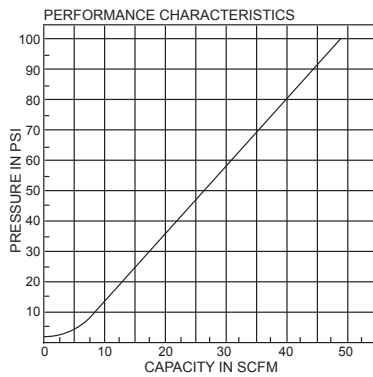

Model Number	Dimensions														Shipping Weight	
	A		B		C		D		E		F		G		Lbs	Kg
	In	mm	In	mm	In	mm	In	mm	In	mm	In	mm	In	mm		
747	3/4	19	3/8	10	4 1/4	108	4	102	1 1/4	44	9 1/2	241	1	25	8	3.6

All dimensions and weights are approximate.

Job Name _____	Notes _____
Engineer _____	_____
Contractor _____	_____
P.O. No. _____	_____
Sales Rep. _____	_____
Model No. _____	_____





COMPRESSION TANKS

AC Series ASME

Construction

Shell	ASME Approved Carbon Steel
Diaphragm	N/A
Liner Material	N/A
Finish	Red Oxide primer

Performance

Maximum Operating Temperature	450°F (115°C)
Maximum Working Pressure	150 PSIG 15-60 gallon 125 PSIG 80-525 gallon
Warranty	3-Years

Application

- For use in closed, non-potable hydronic heating and chilled water systems.
- Designed and constructed per ASME Code Section VIII, Division 1.

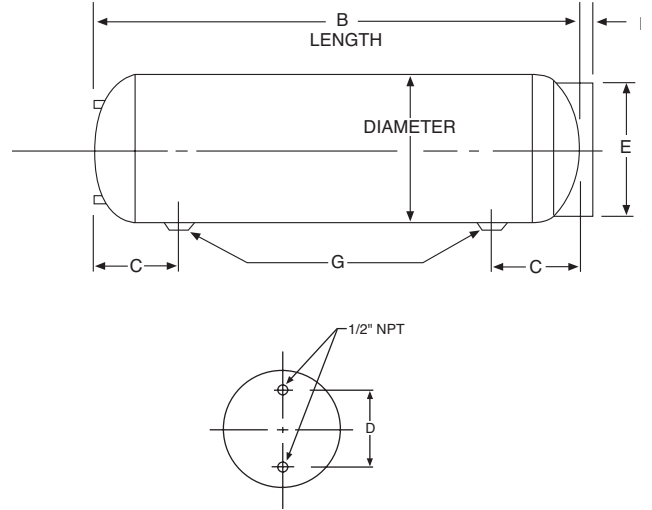

AC Series - Plain Steel

Model Number	Tank Volume		A Tank Diameter		B Tank Length		C	D	E	F	G	Shipping Weight	
	Gal	Lit	In	mm	In	mm						In	In
AC12-15	15	57	12	305	33	383	7	8	11½	7/8	1	44	20
AC12-24	24	91	12	305	51	1295	7	8	11½	7/8	1	62	28
AC14-30	30	114	14	356	48	1219	8¾	10	11½	1⅛	1	72	33
AC14-40	40	151	14	356	63	1600	8¾	10	11½	1⅛	1	92	42
AC16-60	60	227	16	406	72	1829	9¼	12	11½	1½	1	120	54
AC20-80	80	303	20	508	63	1600	10	16	18	1½	1	136	62
AC20-100	100	379	20	508	78	1981	10	16	18	1½	1	168	76
AC24-120	120	454	24	610	65	1651	11⅞	20	18	1½	1	218	99
AC24-135	135	511	24	610	72	1829	11⅞	20	18	1½	1	238	108
AC30-175	175	662	30	762	62	1575	13½	22	18	1½	1	338	153
AC30-220	220	833	30	762	77	1956	13½	22	24	2	1½	368	167
AC30-240	240	908	30	762	84	2134	13½	22	24	2	1½	394	179
AC30-305	305	1155	30	762	106	2692	13½	22	24	2	1½	486	220
AC36-400	400	1514	36	914	93	2362	14¾	28	30	2½	1½	645	293
AC36-505*	505	1912	36	914	120	3048	14¾	28	-	-	1½	810	367

*Ring stand not provided on 505 gallon tanks
All dimensions and weights are approximate.

Job Name _____	Notes _____
Engineer _____	_____
Contractor _____	_____
P.O. No. _____	_____
Sales Rep. _____	_____
Model No. _____	_____





CHILLED WATER BUFFER TANKS

CWBT Series for Closed Loop Chiller Systems ASME

125 PSIG Working Pressure

Construction

Body	ASME Approved Steel
Flanges	ASME Class 150
Paint	Red Oxide Primer
Auxiliary Connection	Top Vent & Bottom Drain Standard

Performance

Maximum Operating Temperature	450° F / 232°C
Maximum Working Pressure	125 psi / 8.8 Bar
Warranty	3-Years

Application

- For use in closed loop chiller systems.
- Available with optional seismic restraints.
- Designed and constructed per ASME Code Section VIII, Division 1.

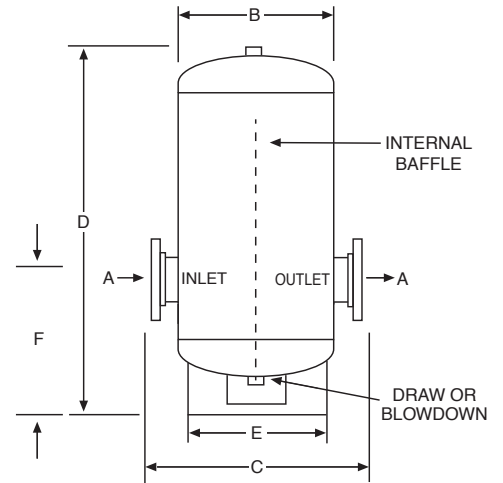

ASME Models

Model Number	Volume Gal	Dimensions						Shipping Weight	
		Conn. Size A	B	C	D	E	F	Lbs	Kg
		In	In	In	In	In	In		
CWBT120-3-125	120	3	24	33	55 $\frac{3}{4}$	16	15	294	133
CWBT120-4-125	120	4	24	33	55 $\frac{3}{4}$	16	15 $\frac{1}{2}$	315	143
CWBT120-6-125	120	6	24	33	55 $\frac{3}{4}$	16	16 $\frac{1}{2}$	333	151
CWBT200-3-125	200	3	30	39	62 $\frac{3}{8}$	24	21 $\frac{1}{2}$	527	239
CWBT200-4-125	200	4	30	39	62 $\frac{3}{8}$	24	22	547	248
CWBT200-6-125	200	6	30	39	62 $\frac{3}{8}$	24	23	566	257
CWBT300-4-125	300	4	36	45	80 $\frac{3}{8}$	30	32 $\frac{1}{8}$	753	342
CWBT300-6-125	300	6	36	45	80 $\frac{3}{8}$	30	33 $\frac{1}{8}$	772	350
CWBT300-8-125	300	8	36	45	80 $\frac{3}{8}$	30	34 $\frac{1}{8}$	801	363
CWBT500-6-125	500	6	42	51	99 $\frac{1}{2}$	30	36 $\frac{1}{2}$	1366	620
CWBT500-8-125	500	8	42	51	99 $\frac{1}{2}$	30	37 $\frac{1}{2}$	1395	633
CWBT500-10-125	500	10	42	51	99 $\frac{1}{2}$	30	38 $\frac{1}{2}$	1490	676
CWBT850-6-125	850	6	54	64	114 $\frac{1}{16}$	42	39 $\frac{1}{2}$	2707	1228
CWBT850-8-125	850	8	54	64	114 $\frac{1}{16}$	42	40 $\frac{1}{2}$	2736	1241
CWBT850-10-125	850	10	54	64	114 $\frac{1}{16}$	42	41 $\frac{1}{2}$	2771	1257
CWBT1040-8-125	1040	8	60	70	107 $\frac{7}{8}$	45	36	3136	1423
CWBT1040-10-125	1040	10	60	70	107 $\frac{7}{8}$	45	37	3171	1438
CWBT1040-12-125	1040	12	60	70	107 $\frac{7}{8}$	45	38	3283	1489

All dimensions and weights are approximate.

Job Name _____	Notes _____
Engineer _____	_____
Contractor _____	_____
P.O. No. _____	_____
Sales Rep. _____	_____
Model No. _____	_____





CHILLED WATER BUFFER TANKS

CWBT Series for Closed Loop Chiller Systems ASME

150 PSIG Working Pressure

Construction

Body	ASME Approved Steel
Flanges	ASME Class 150
Paint	Red Oxide Primer
Auxiliary Connection	Top Vent & Bottom Drain Standard

Performance

Maximum Operating Temperature	450° F / 232°C
Maximum Working Pressure	150 psi / 10.3 Bar
Warranty	3-Years

Application

- For use in closed loop chiller systems.
- Available with optional seismic restraints.
- Designed and constructed per ASME Code Section VIII, Division 1.

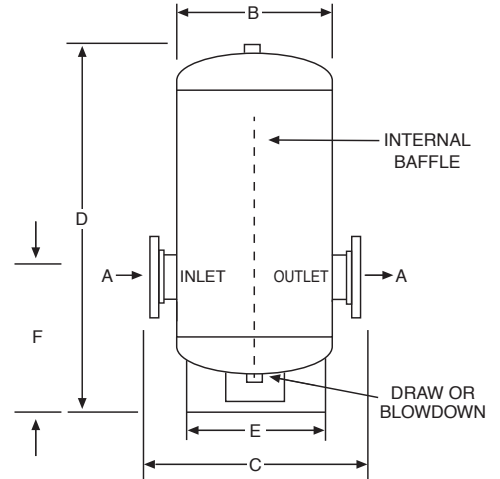

ASME Models

Model Number	Volume Gal	Dimensions						Shipping Weight	
		Conn. Size A	B	C	D	E	F	Lbs	Kg
		In	In	In	In	In	In		
CWBT120-3-150	120	3	24	33	55 ³ / ₄	16	15	323	147
CWBT120-4-150	120	4	24	33	55 ³ / ₄	16	15 ¹ / ₂	347	157
CWBT120-6-150	120	6	24	33	55 ³ / ₄	16	16 ¹ / ₂	366	166
CWBT200-3-150	200	3	30	39	62 ³ / ₈	24	21 ¹ / ₂	580	263
CWBT200-4-150	200	4	30	39	62 ³ / ₈	24	22	602	273
CWBT200-6-150	200	6	30	39	62 ³ / ₈	24	23	623	283
CWBT300-4-150	300	4	36	45	80 ³ / ₈	30	32 ³ / ₈	828	376
CWBT300-6-150	300	6	36	45	80 ³ / ₈	30	33 ³ / ₈	849	385
CWBT300-8-150	300	8	36	45	80 ³ / ₈	30	34 ³ / ₈	881	400
CWBT500-6-150	500	6	42	51	99 ¹ / ₂	30	36 ¹ / ₂	1503	682
CWBT500-8-150	500	8	42	51	99 ¹ / ₂	30	37 ¹ / ₂	1535	696
CWBT500-10-150	500	10	42	51	99 ¹ / ₂	30	38 ¹ / ₂	1639	743
CWBT850-6-150	850	6	54	64	114 ¹ / ₁₆	42	39 ¹ / ₂	2978	1351
CWBT850-8-150	850	8	54	64	114 ¹ / ₁₆	42	40 ¹ / ₂	3010	1365
CWBT850-10-150	850	10	54	64	114 ¹ / ₁₆	42	41 ¹ / ₂	3048	1383
CWBT1040-8-150	1040	8	60	70	107 ³ / ₈	45	36	3450	1565
CWBT1040-10-150	1040	10	60	70	107 ³ / ₈	45	37	3488	1582
CWBT1040-12-150	1040	12	60	70	107 ³ / ₈	45	38	3611	1638

All dimensions and weights are approximate.

Job Name _____	Notes _____
Engineer _____	_____
Contractor _____	_____
P.O. No. _____	_____
Sales Rep. _____	_____
Model No. _____	_____





2 PORT HOT WATER BUFFER

HWBT Series for Hot Water Systems ASME

125 PSIG Working Pressure

Construction

Body	ASME Approved Steel
Flanges	ASME Class 150
Paint	Red Oxide Primer
Auxiliary Connection	Top Vent & Bottom Drain Standard

Performance

Maximum Operating Temperature	450° F / 232°C
Maximum Working Pressure	125 psi / 8.8 Bar
Warranty	3-Years

Application

- For use in hydronic systems.
- Designed and constructed per ASME Code Section VIII, Division 1.
- Available with optional seismic restraints.

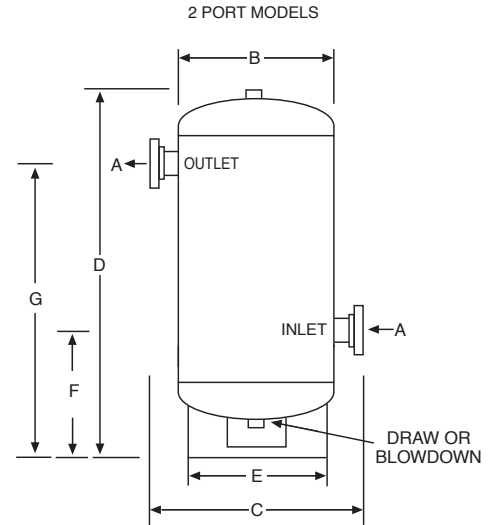

ASME Models

Model Number	Number of Ports	Volume Gal	Dimensions								Shipping Weight	
			Conn. Size A	B	C	D	E	F	G	H	Lbs	Kg
			In	In	In	In	In	In	In	In		
HWBT120-2-125	2	120	2	24	33 $\frac{3}{4}$	55 $\frac{3}{4}$	16	15	45	-	254	115
HWBT120-3-125	2	120	3	24	33 $\frac{3}{4}$	55 $\frac{3}{4}$	16	15	45	-	268	122
HWBT200-2-125	2	200	2	30	39	62 $\frac{1}{2}$	24	21 $\frac{1}{2}$	45 $\frac{1}{2}$	-	475	216
HWBT200-3-125	2	200	3	30	39 $\frac{3}{8}$	62 $\frac{1}{2}$	24	21 $\frac{1}{2}$	45 $\frac{1}{2}$	-	490	222
HWBT300-2-125	2	300	2	36	45 $\frac{1}{8}$	80 $\frac{3}{8}$	30	32 $\frac{1}{4}$	61 $\frac{1}{4}$	-	668	303
HWBT300-2.5-125	2.5	300	2.5	36	45 $\frac{1}{8}$	80 $\frac{3}{8}$	30	32 $\frac{1}{8}$	61	-	677	307
HWBT300-3-125	2	300	3	36	45 $\frac{1}{8}$	80 $\frac{3}{8}$	30	32 $\frac{1}{8}$	61	-	683	310

All dimensions and weights are approximate.

Job Name _____	Notes _____
Engineer _____	_____
Contractor _____	_____
P.O. No. _____	_____
Sales Rep. _____	_____
Model No. _____	_____





2 PORT HOT WATER BUFFER

HWBT Series for Hot Water Systems ASME

150 PSIG Working Pressure

Construction

Body	ASME Approved Steel
Flanges	ASME Class 150
Paint	Red Oxide Primer
Auxiliary Connection	Top Vent & Bottom Drain Standard

Performance

Maximum Operating Temperature	450° F / 232°C
Maximum Working Pressure	150 psi / 10.5 Bar
Warranty	3-Years

Application

- For use in hydronic systems.
- Designed and constructed per ASME Code Section VIII, Division 1.
- Available with optional seismic restraints.

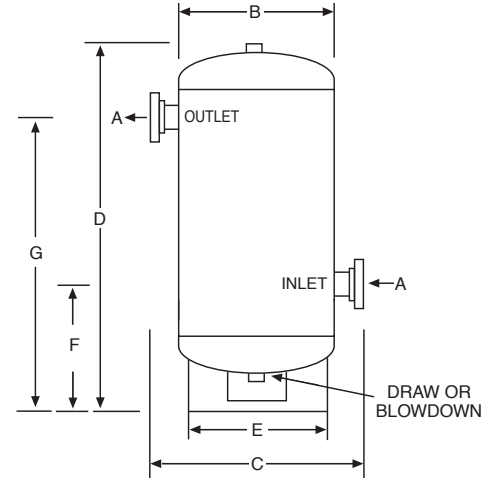

ASME Models

Model Number	Number of Ports	Volume Gal	Dimensions								Shipping Weight	
			Conn. Size A	B	C	D	E	F	G	H	Lbs	Kg
			In	In	In	In	In	In	In	In		
HWBT120-2-150	2	120	2	24	33 $\frac{1}{8}$	55 $\frac{3}{4}$	16	15	45	-	279	127
HWBT120-3-150	2	120	3	24	33 $\frac{1}{8}$	55 $\frac{3}{4}$	16	15	45	-	295	134
HWBT200-2-150	2	200	2	30	39	62 $\frac{1}{2}$	24	21 $\frac{1}{2}$	45 $\frac{1}{2}$	-	523	237
HWBT200-3-150	2	200	3	30	39 $\frac{1}{8}$	62 $\frac{1}{2}$	24	21 $\frac{1}{2}$	45 $\frac{1}{2}$	-	539	244
HWBT300-2-150	2	300	2	36	45 $\frac{1}{8}$	80 $\frac{3}{8}$	30	32 $\frac{1}{4}$	61 $\frac{1}{4}$	-	735	333
HWBT300-2.5-150	2.5	300	2.5	36	45 $\frac{1}{8}$	80 $\frac{3}{8}$	30	32 $\frac{1}{8}$	61	-	745	338
HWBT300-3-150	2	300	3	36	45 $\frac{1}{8}$	80 $\frac{3}{8}$	30	32 $\frac{1}{8}$	61	-	751	341

All dimensions and weights are approximate.

Job Name _____	Notes _____
Engineer _____	_____
Contractor _____	_____
P.O. No. _____	_____
Sales Rep. _____	_____
Model No. _____	_____





4 PORT HOT WATER BUFFER

HWBT Series for Hot Water Systems ASME

125 PSIG Working Pressure

Construction

Body	ASME Approved Steel
Flanges	ASME Class 150
Paint	Red Oxide Primer
Auxiliary Connection	Top Vent & Bottom Drain Standard

Performance

Maximum Operating Temperature	450° F / 232°C
Maximum Working Pressure	125 psi / 8.8 Bar
Warranty	3-Years

Application

- For use in hydronic systems.
- Designed and constructed per ASME Code Section VIII, Division 1.
- Available with optional seismic restraints.

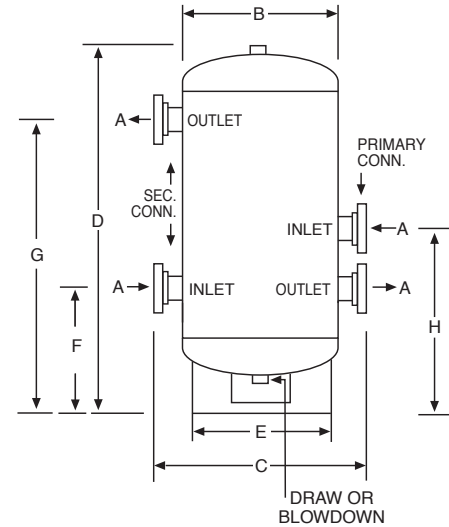

ASME Models

Model Number	Number of Ports	Volume Gal	Dimensions								Shipping Weight	
			A	B	C	D	E	F	G	H	Lbs	Kg
			Conn. In Pri./Sec.	In	In	In	In	In	In	In		
HWBT120-2/2-125	4	120	2/2	24	33 ³ / ₈	55 ³ / ₄	16	15	45	27	267	121
HWBT120-2/3-125	4	120	2/3	24	33 ³ / ₈	55 ³ / ₄	16	15	45	27	282	128
HWBT120-3/3-125	4	120	3/3	24	33 ³ / ₈	55 ³ / ₄	16	15	45	27	297	135
HWBT120-4/4-125	4	120	4/4	24	33 ³ / ₈	55 ³ / ₄	16	15 ¹ / ₂	44 ¹ / ₂	27 ¹ / ₂	338	153
HWBT120-6/6-125	4	120	6/6	24	33 ³ / ₈	55 ³ / ₄	16	15 ¹ / ₂	44 ¹ / ₂	27 ¹ / ₂	356	161
HWBT200-2/2-125	4	200	2/2	30	39	62 ¹ / ₂	24	21 ¹ / ₂	45 ¹ / ₂	35 ¹ / ₂	489	222
HWBT200-2/3-125	4	200	2/3	30	39	62 ¹ / ₂	24	21 ¹ / ₂	45 ¹ / ₂	35 ¹ / ₂	503	228
HWBT200-3/3-125	4	200	3/3	30	39 ³ / ₈	62 ¹ / ₂	24	21 ¹ / ₂	45 ¹ / ₂	35 ¹ / ₂	518	235
HWBT200-4/4-125	4	200	4/4	30	39 ³ / ₈	62 ¹ / ₂	24	21 ¹ / ₂	45 ¹ / ₂	35 ¹ / ₂	560	254
HWBT300-2/2-125	4	300	2/2	36	45 ³ / ₈	80 ³ / ₈	30	32 ¹ / ₄	61 ¹ / ₄	48 ¹ / ₄	682	309
HWBT300-2/3-125	4	300	2/3	36	45 ³ / ₈	80 ³ / ₈	30	32 ¹ / ₈	61	48 ¹ / ₈	696	316
HWBT300-3/3-125	4	300	3/3	36	45 ³ / ₈	80 ³ / ₈	30	32 ¹ / ₈	61	48 ¹ / ₈	711	323
HWBT300-4/4-125	4	300	4/4	36	45 ³ / ₈	80 ³ / ₈	30	32 ¹ / ₈	61	48 ¹ / ₈	753	342

All dimensions and weights are approximate.

Job Name _____	Notes _____
Engineer _____	_____
Contractor _____	_____
P.O. No. _____	_____
Sales Rep. _____	_____
Model No. _____	_____





4 PORT HOT WATER BUFFER

HWBT Series for Hot Water Systems ASME

150 PSIG Working Pressure

Construction

Body	ASME Approved Steel
Flanges	ASME Class 150
Paint	Red Oxide Primer
Auxiliary Connection	Top Vent & Bottom Drain Standard

Performance

Maximum Operating Temperature	450° F / 232°C
Maximum Working Pressure	150 psi / 10.5 Bar
Warranty	3-Years

Application

- For use in hydronic systems.
- Designed and constructed per ASME Code Section VIII, Division 1.
- Available with optional seismic restraints.

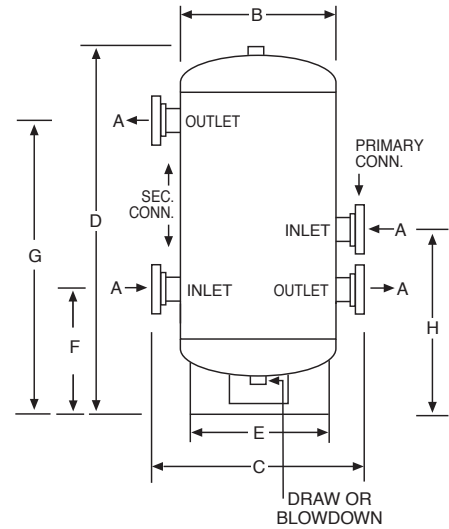

ASME Models

Model Number	Number of Ports	Volume Gal	Dimensions								Shipping Weight	
			A	B	C	D	E	F	G	H	Lbs	Kg
			Conn. In Pri./Sec.	In	In	In	In	In	In	In		
HWBT120-2/2-150	4	120	2/2	24	33 ¹ / ₈	55 ³ / ₄	16	15	45	27	294	133
HWBT120-2/3-150	4	120	2/3	24	33 ¹ / ₈	55 ³ / ₄	16	15	45	27	310	141
HWBT120-3/3-150	4	120	3/3	24	33 ¹ / ₈	55 ³ / ₄	16	15	45	27	327	148
HWBT120-4/4-150	4	120	4/4	24	33 ¹ / ₈	55 ³ / ₄	16	15 ¹ / ₂	44 ¹ / ₂	27 ¹ / ₂	372	169
HWBT120-6/6-150	4	120	6/6	24	33 ¹ / ₈	55 ³ / ₄	16	15 ¹ / ₂	44 ¹ / ₂	27 ¹ / ₂	392	178
HWBT200-2/2-150	4	200	2/2	30	39	62 ¹ / ₂	24	21 ¹ / ₂	45 ¹ / ₂	35 ¹ / ₂	538	244
HWBT200-2/3-150	4	200	2/3	30	39	62 ¹ / ₂	24	21 ¹ / ₂	45 ¹ / ₂	35 ¹ / ₂	553	251
HWBT200-3/3-150	4	200	3/3	30	39 ¹ / ₈	62 ¹ / ₂	24	21 ¹ / ₂	45 ¹ / ₂	35 ¹ / ₂	570	259
HWBT200-4/4-150	4	200	4/4	30	39 ¹ / ₈	62 ¹ / ₂	24	21 ¹ / ₂	45 ¹ / ₂	35 ¹ / ₂	617	280
HWBT300-2/2-150	4	300	2/2	36	45 ¹ / ₈	80 ³ / ₈	30	32 ¹ / ₄	61 ¹ / ₄	48 ³ / ₄	750	340
HWBT300-2/3-150	4	300	2/3	36	45 ¹ / ₈	80 ³ / ₈	30	32 ¹ / ₈	61	48 ¹ / ₈	766	347
HWBT300-3/3-150	4	300	3/3	36	45 ¹ / ₈	80 ³ / ₈	30	32 ¹ / ₈	61	48 ¹ / ₈	782	355
HWBT300-4/4-150	4	300	4/4	36	45 ¹ / ₈	80 ³ / ₈	30	32 ¹ / ₈	61	48 ¹ / ₈	828	376

All dimensions and weights are approximate.

Job Name _____	Notes _____
Engineer _____	_____
Contractor _____	_____
P.O. No. _____	_____
Sales Rep. _____	_____
Model No. _____	_____





FIRE-X-TROL®

Fire Protection Expansion Tanks: FPT Series ASME

175 PSIG Working Pressure

Construction

Shell	ASME Approved Steel
Diaphragm	High-Performance Rubber Compound
Liner Material	Polypropylene
System Connection	Stainless Steel
Finish	FPT Red
Air Valve	Schrader Valve w/EPDM Seats
Factory Precharge	25 PSIG (1.7 bar)

Performance

Min./Max. Operating Temperatures	-20°F (-29°C) to 200°F (93°C)
Maximum Working Pressure	175 PSIG (12 bar)
Warranty	3-Years

Application

- For use in fire protection systems.
- Accommodates the expanded volume of system fluids that result from temperature changes.
- Keeps system pressure below the pressure limitations of system components to prevent damage.
- Can be used with water, glycerin and propylene glycol systems.
- Designed and constructed per ASME Code Section VIII, Division 1.
- Sight glass and seismic restraints available on Models FPT-20VC through FPT-210VC.

ASME In-Line Models

Model Number	Tank Volume		A Tank Height		B Tank Diameter		System Conn. (NPTF)	Shipping Weight	
	Gal	Lit	In	mm	In	mm		Lbs	Kg
FPT-5C	2.1	8.0	10 ³ / ₈	264	10	254	³ / ₄	21	10
FPT-12C	6.4	24.0	15 ⁵ / ₈	397	12	305	³ / ₄	36	15

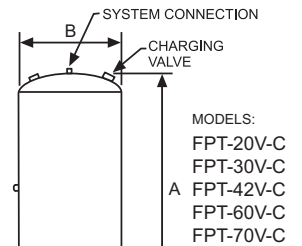
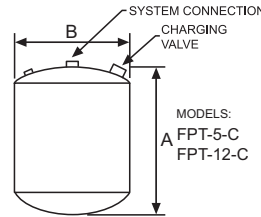

ASME Stand Models

Model Number	Tank Volume		A Tank Height		B Tank Diameter		C Stand Diameter		System Conn. (NPTF)	Shipping Weight	
	Gal	Lit	In	mm	In	mm	In	mm		Lbs	Kg
FPT-20VC	8.0	30	19 ¹ / ₂	495	12	305	10 ³ / ₄	273	³ / ₄	52	24
FPT-30VC	14.0	53	19 ¹ / ₈	486	16 ¹ / ₄	419	12 ³ / ₄	324	³ / ₄	97	44
FPT-42VC	17.5	66	24 ¹ / ₄	616	16 ¹ / ₄	419	12 ³ / ₄	324	³ / ₄	116	53
FPT-60VC	25.0	95	33	838	16 ¹ / ₄	419	12 ³ / ₄	324	³ / ₄	154	70
FPT-70VC	34.0	129	41 ¹ / ₂	1054	16 ¹ / ₄	419	12 ³ / ₄	324	³ / ₄	197	90
FPT-80VC	53.0	200	35 ³ / ₄	908	24	610	16	406	1 ¹ / ₄	251	114
FPT-120VC	66.0	250	43 ³ / ₄	1111	24	610	16	406	1 ¹ / ₄	281	128
FPT-180VC	77.0	292	48 ³ / ₄	1235	24	610	16	406	1 ¹ / ₄	353	160
FPT-210VC	90.0	341	55 ¹ / ₂	1410	24	610	16	406	1 ¹ / ₄	382	173

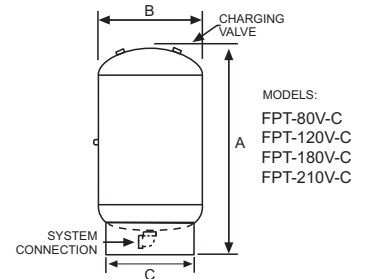

All dimensions and weights are approximate.

Job Name _____	Notes _____
Engineer _____	_____
Contractor _____	_____
P.O. No. _____	_____
Sales Rep. _____	_____
Model No. _____	_____





FIRE-X-TROL®

Fire Protection Expansion Tanks: FPT Series Non-ASME

175 PSIG Working Pressure

Construction

Shell	ASME Approved Steel
Diaphragm	High-Performance Rubber Compound
Liner Material	Polypropylene
System Connection	Stainless Steel
Finish	FPT Red
Air Valve	Schrader Valve w/EPDM Seats
Factory Precharge	25 PSIG (1.7 bar)

Application

- For use in fire protection systems.
- Accommodates the expanded volume of system fluids that result from temperature changes.
- Keeps system pressure below the pressure limitations of system components to prevent damage.
- Can be used with water, glycerin and propylene glycol systems.
- Sight glass and seismic restraints available on Models FPT-20VC through FPT-210VC.

Performance

Min./Max. Operating Temperatures	-20°F (-29°C) to 200°F (93°C)
Maximum Working Pressure	175 PSIG (12 bar)
Warranty	3-Years

In-Line Models

Model Number	Tank Volume		A Tank Height		B Tank Diameter		System Conn. (NPTF)	Shipping Weight	
	Gal	Lit	In	mm	In	mm		Lbs	Kg
FPT-5	2.1	8.0	10 ³ / ₈	264	10	254	³ / ₄	21	10
FPT-12	6.4	24.0	15 ⁵ / ₈	397	12	305	³ / ₄	36	15

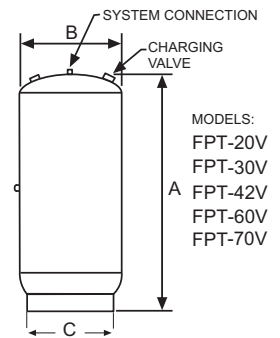
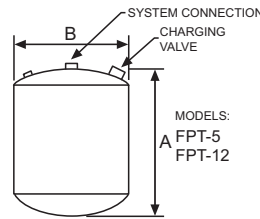

Stand Models

Model Number	Tank Volume		A Tank Height		B Tank Diameter		C Stand Diameter		System Conn. (NPTF)	Shipping Weight	
	Gal	Lit	In	mm	In	mm	In	mm		Lbs	Kg
FPT-20V	8.0	30	19 ¹ / ₂	495	12	305	10 ³ / ₄	273	³ / ₄	52	24
FPT-30V	14.0	53	19 ⁵ / ₈	486	16 ¹ / ₄	419	12 ³ / ₄	324	³ / ₄	97	44
FPT-42V	17.5	66	24 ¹ / ₄	616	16 ¹ / ₄	419	12 ³ / ₄	324	³ / ₄	116	53
FPT-60V	25.0	95	33	838	16 ¹ / ₄	419	12 ³ / ₄	324	³ / ₄	154	70
FPT-70V	34.0	129	41 ¹ / ₂	1054	16 ¹ / ₄	419	12 ³ / ₄	324	³ / ₄	197	90
FPT-80V	53.0	200	35 ³ / ₄	908	24	610	16	406	1 ¹ / ₄	251	114
FPT-120V	66.0	250	43 ³ / ₄	1111	24	610	16	406	1 ¹ / ₄	281	128
FPT-180V	77.0	292	48 ³ / ₄	1235	24	610	16	406	1 ¹ / ₄	353	160
FPT-210V	90.0	341	55 ¹ / ₂	1410	24	610	16	406	1 ¹ / ₄	382	173

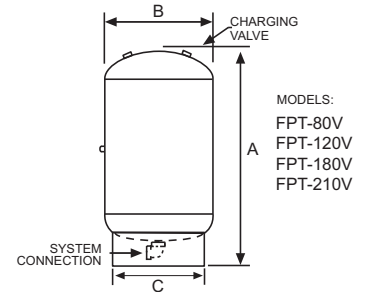

All dimensions and weights are approximate.

Job Name _____	Notes _____
Engineer _____	_____
Contractor _____	_____
P.O. No. _____	_____
Sales Rep. _____	_____
Model No. _____	_____





SURGE-TROL®

Fire Protection Expansion Tanks: SPT Series ASME

275 PSIG Working Pressure

Construction

Shell	ASME Approved Steel
Bladder Material	Heavy Duty Butyl/NSF/ANSI 61
Bladder Thickness	.100 Minimum
System Connection	Steel - ANSI Flange
Finish	Red Oxide Primer
Air Valve	Schrader Valve w/EPDM Seats
Factory Precharge	25 PSIG (1.7 bar)

Performance

Maximum Operating Temperature	240°F (115°C)
Maximum Working Pressure	275 PSIG (19 bar)
Warranty	3-Year

Application

- For use in absorption of pump start-up and shut-down surges in fire protection sprinkler systems.
- Replaceable, heavy-duty bladder design.
- Compatible with glycerin, propylene glycol and ethylene systems.
- Seismic restraints come standard; sight glass is optional.
- Designed and constructed per ASME Code Section VIII, Division 1.

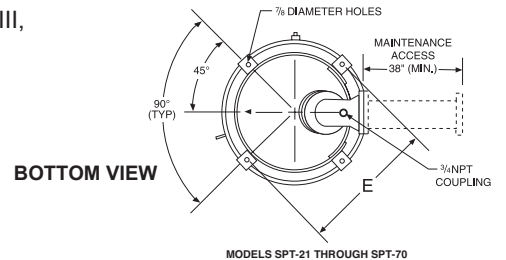
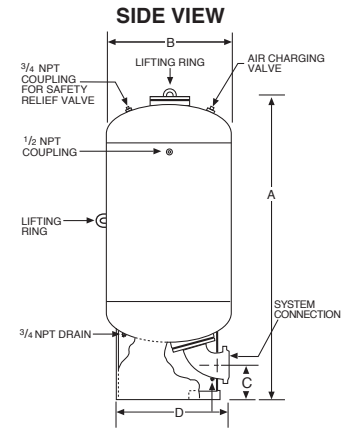

ASME Models

Model Number	Tank Volume		A Tank Height		B Tank Diameter		Sys. Conn.		C Conn. Centerline		D Stand Diameter		E Bottom Diameter		Shipping Weight	
	Gal	Lit	In	mm	In	mm	In	mm	In	mm	In	mm	In	mm	Lbs	Kg
SPT-1	10	38	31	787	16	406	2	51	5½	140	16	406	19	483	200	91
SPT-3	25	95	49	1245	16	406	3	76	5½	140	16	406	19	483	273	124
SPT-7	53	200	49	1245	24	610	4	102	7¾	197	19	483	23	584	390	177
SPT-11	80	300	63	1600	24	610	4	102	7¾	197	19	483	23	584	505	229
SPT-14	106	400	77	1956	24	610	4	102	7¾	197	19	483	23	584	618	280
SPT-18	132	500	91	2311	24	610	4	102	7¾	197	19	483	23	584	731	332
SPT-21	158	600	75	1905	30	762	4	102	8%	213	24	610	28	711	950	431
SPT-28	211	800	93	2362	30	762	4	102	8%	213	24	610	28	711	1125	510
SPT-35	264	1000	85	2159	36	914	6	152	10¼	213	30	762	34	864	1520	689
SPT-42	317	1200	97	2464	36	914	6	152	10¼	260	30	762	34	864	1720	780
SPT-50	370	1400	110	2794	36	914	6	152	10¼	260	30	762	34	864	1900	862
SPT-56	422	1600	86	2184	48	1219	8	203	12¼	311	42	1067	46	1168	2300	1043
SPT-70	528	2000	100	2540	48	1219	8	203	12¼	311	42	1067	46	1168	2700	1225

All dimensions and weights are approximate.

Job Name _____	Notes _____
Engineer _____	_____
Contractor _____	_____
P.O. No. _____	_____
Sales Rep. _____	_____
Model No. _____	_____





1400 Division Road, West Warwick, RI 02893 USA
T: 800.426.8765 www.amtrol.com