



FILL-TROL®

COMBINATION EXPANSION TANK AND AUTO FILL VALVE UNIT

INSTALLATION & OPERATION INSTRUCTIONS

Models FT-109 through FT-111
For Use In Closed Hydronic Systems Only



NOTE: Inspect for shipping damage. Notify freight carrier or store where purchased immediately if damage is present. To avoid risk of personal injury and property damage, if the product appears to be malfunctioning, shows signs of corrosion, or if indicator cap is discolored, call a licensed professional immediately. Current copies of the product manual can be viewed at www.amtrol.com. Use proper safety equipment when installing.



THIS IS THE SAFETY ALERT SYMBOL. IT IS USED TO ALERT YOU TO POTENTIAL PERSONAL INJURY AND OTHER HAZARDS. OBEY ALL SAFETY MESSAGES THAT FOLLOW THIS SYMBOL TO REDUCE THE RISK OF PERSONAL INJURY AS WELL AS PROPERTY DAMAGE.

WARNING **USE ONLY IN RESIDENTIAL CLOSED HYDRONIC SYSTEMS.** Do not install on domestic water systems, or in open heating systems. Corrosion and tank failure may result. Use a Therm-X-Trol® or Therm-X-Span® for domestic water systems. Use a Radiant EXTROL® for radiant heating systems where air elimination equipment or barrier tubing is not used.

WARNING **READ CAREFULLY THE PRODUCT INSTALLATION, OPERATING AND MAINTENANCE MANUAL. FAILURE TO FOLLOW THE INSTRUCTIONS AND WARNINGS IN THE MANUAL MAY RESULT IN SERIOUS OR FATAL INJURY AND/OR PROPERTY DAMAGE, AND WILL VOID THE PRODUCT WARRANTY. THIS PRODUCT MUST BE INSTALLED BY A LICENSED PROFESSIONAL. FOLLOW ALL APPLICABLE LOCAL AND STATE CODES AND REGULATIONS, IN THE ABSENCE OF SUCH CODES, FOLLOW THE CURRENT EDITIONS OF THE NATIONAL PLUMBING CODE AND NATIONAL ELECTRIC CODE, AS APPLICABLE.**

WARNING This Product, like most Products under pressure, may over time corrode, weaken and burst or explode, causing serious or fatal injury, leaking or flooding and/or property damage. To minimize risk, a licensed professional must install and periodically inspect and service the Product. A drip pan connected to an adequate drain must be installed if leaking or flooding could cause property damage. Do not locate in an area where leaking could cause property damage to the area adjacent to the appliance or to lower floors of the structure.

WARNING **RUPTURE OR EXPLOSION HAZARD.** Do not expose product to freezing temperatures or

temperatures in excess of 240°F. Do not adjust the pre-charge or re-charge this Product except during installation or regular inspection. Replace the Product and do not adjust the pre-charge if corroded, damaged or with diminished integrity. Adjustments to pre-charge must be done at ambient temperature only. Failure to properly size the Product or follow these instructions may result in excessive strain on the system and may lead to Product failure, serious or fatal personal injury, leakage, and/or property damage.

WARNING A relief valve must be installed to prevent pressure in excess of local code requirement or maximum working pressure designated in the Product Manual, whichever is less. At least once every 3 years or if discharge is present, a licensed professional should inspect the pressure relief valve and replace if corrosion is evident or the valve does not function. **FAILURE TO INSPECT THIS VALVE AS DIRECTED COULD RESULT IN UNSAFE PRESSURE BUILD-UP WHICH CAN RESULT IN PRODUCT FAILURE, SERIOUS INJURY OR DEATH AND/OR SEVERE PROPERTY DAMAGE AND VOID THE PRODUCT WARRANTY.**

WARNING **Chlorine & Aggressive Water:** The water quality can significantly influence the life of this Product. You should test for corrosive elements, acidity, total solids and other relevant contaminants, including chlorine and treat your water appropriately to insure satisfactory performance and prevent premature failure.

WARNING This product can expose you to chemicals including lead, which is known to the State of California to cause cancer and birth defects or other reproductive harm. For more information go to www.P65Warnings.ca.gov.

PLEASE READ THE FOLLOWING INSTRUCTIONS CAREFULLY
IMPORTANT GENERAL SAFETY INFORMATION -
ADDITIONAL SPECIFIC SAFETY ALERTS APPEAR IN THE FOLLOWING INSTRUCTIONS.

FILL-TROL® is a combination of an EXTROL® expansion tank and a specially designed automatic fill valve. Together, they manage water expansion and provide make-up water to provide satisfactory heating system.

Pre-Installation

1. Visually inspect for any damage. Ensure expansion tank is sized properly for the application (Figure 1).
2. With tank empty of water, remove plastic cap from air stem (Figure 2).
3. Adjust air precharge to desired system fill pressure. Unit is shipped at 12 PSIG.
4. Replace cap and tighten snugly, ensuring the cap is flush against the tank surface.

WARNING FAILURE TO PROPERLY SEAL VALVE CAP WILL RESULT IN LOSS OF PRECHARGE CAUSING PRODUCT TO FAIL.

Figure 1.

Boiler Net Output in 1000'S of BTU/Hr.	Type of Radiation			
	Finned Tube Baseboard or Radiant Panel	Convectors or Unit Heaters	Radiators Cast Iron	Baseboard Cast Iron
25	FT-109	FT-109	FT-109	FT-109
50	FT-109	FT-109	FT-110	FT-110
75	FT-110	FT-110	FT-110	FT-111
100	FT-110	FT-110	FT-111	FT-111
125	FT-110	FT-111	FT-111	NA
150	FT-110	FT-111	NA	NA
175	FT-111	FT-111	NA	NA
200	FT-111	FT-111	NA	NA
250	FT-111	NA	NA	NA

Sizing based on: 12 psig Fill; 30 psig Relief Valve; 200°F Average Temperature.

Figure 2.

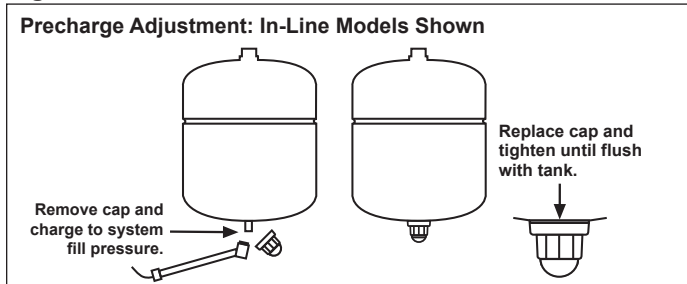

Installation

1. Drain the boiler system or isolate the area where the Fill-Trol will be installed.
2. Install the Fill-Trol on the supply side of the boiler, on the suction-side of the heating circulator(s) (Figure 3).

WARNING Mount tank vertically only. Ensure the piping can support the entire weight of the tank when full of water.

WARNING Do not install on a dead-end pipe or wherever air can collect; causing internal corrosion and possible leakage.

3. Make connection to heating system with 1/2" tapping marked SYSTEM.
4. Connect cold water supply to 1/2" compression fitting connection marked SUPPLY
5. Pressurize the system and check for leaks. Repair as necessary.
6. Restart the boiler system and check for relief valve discharge. If the relief valve drips, the tank may be improperly charged or undersized.

Operation

Water enters the Fill-Trol valve, passes through the removable strainer and pushes open a spring-loaded check valve. It then flows through the automatic shut-off valve which is held in the open position by the diaphragm pushing against a pressure plate. This raises the fill-gate stem allowing water to flow into the heating system. It is the precharge pressure in the tank that sets the fill pressure.

The Fill-Trol is shipped with a factory precharge of 12 PSIG which automatically sets the minimum fill pressure to 12 PSIG. Other minimum fill pressures may be used by increasing or decreasing the air charge in the tank. Carefully follow the instructions for changing the air charge.

Maintenance

A licensed professional should check the complete system, including the expansion tank, yearly and more frequently as the system ages. Checking the precharge allows a small quantity of air to escape and can result in an insufficient air charge. Always check the precharge while the tank is isolated and empty of water, and be sure to maintain the proper precharge whenever the tank is inspected. Monitor the tip of the inspection cap for discoloration (Figure 4) in addition to regular product inspection. Contact the installer or a licensed professional if indicator cap is discolored; tank replacement required. Do not rely on cap as sole indication of tank condition.

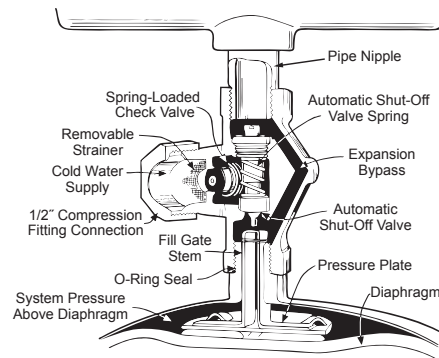

Figure 3.

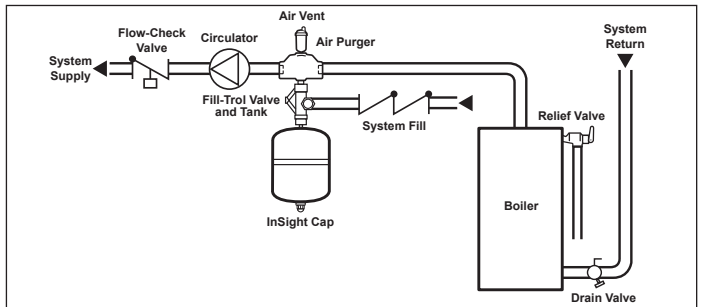
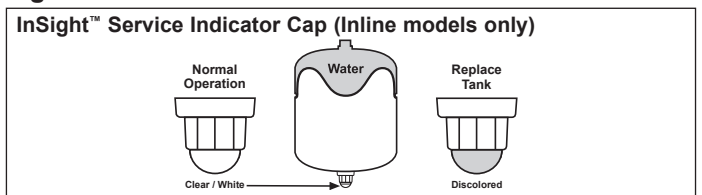

Figure 4.



Warranty

FT Models: Five (5) Year Limited Warranty
 Visit www.amtrol.com for complete warranty details.



1400 Division Road, West Warwick, RI 02893 USA
 T: 800.426.8765 www.amtrol.com

