



# BOILERMATE® INDIRECT-FIRED WATER HEATERS INSTALLATION & OPERATION INSTRUCTIONS

## Models CH (Mechanical Control)



**NOTE:** A properly sized thermal expansion tank is required and should be installed in accordance with the product installation manual.

**NOTE:** The thermostat is adjusted to 120°F when shipped from the factory.

**NOTE:** Inspect for shipping damage and notify freight carrier or store where purchased immediately if damage is present. To avoid risk of personal injury and property damage, if the product appears to be malfunctioning or shows signs of corrosion, call a licensed professional immediately. Current copies of the Product manual can be viewed at [www.amtrol.com](http://www.amtrol.com). Use proper safety equipment when installing.



**THIS IS THE SAFETY ALERT SYMBOL. IT IS USED TO ALERT YOU TO POTENTIAL PERSONAL INJURY AND OTHER HAZARDS. OBEY ALL SAFETY MESSAGES THAT FOLLOW THIS SYMBOL TO REDUCE THE RISK OF PERSONAL INJURY AS WELL AS PROPERTY DAMAGE.**

**WARNING** READ CAREFULLY THE PRODUCT INSTALLATION & OPERATION INSTRUCTIONS. FAILURE TO FOLLOW THE INSTRUCTIONS AND WARNINGS IN THE MANUAL MAY RESULT IN SERIOUS OR FATAL INJURY AND/OR PROPERTY DAMAGE, AND WILL VOID THE PRODUCT WARRANTY. THIS PRODUCT MUST BE INSTALLED BY A LICENSED PROFESSIONAL. FOLLOW ALL APPLICABLE LOCAL AND STATE CODES AND REGULATIONS, IN THE ABSENCE OF SUCH CODES, FOLLOW THE CURRENT EDITIONS OF THE NATIONAL PLUMBING CODE AND NATIONAL ELECTRIC CODE, AS APPLICABLE.

**WARNING** DO NOT LIFT OR CARRY WATER HEATER BY THE TOP COVER. WATER HEATER DAMAGE OR PERSONAL INJURY MAY OCCUR IF THE COVER BECOMES DETACHED.

**WARNING** This Product, like most Products under pressure, may over time corrode, weaken and burst or explode, causing serious or fatal injury, leaking or flooding and/or property damage. To minimize risk, a licensed professional must install and periodically inspect and service the Product. A drip pan connected to an adequate drain must be installed if leaking or flooding could cause property damage. Do not locate in an area where leaking could cause property damage to the area adjacent to the appliance or to lower floors of the structure.

**WARNING** A relief valve must be installed to prevent pressure in excess of local code requirement or maximum working pressure designated in the Product Manual, whichever is less. At least once every 3 years or if discharge is present, a licensed contractor should inspect the temperature and pressure relief valve and replace if corrosion is evident or the valve does not function.

**FAILURE TO INSPECT THIS VALVE AS DIRECTED COULD RESULT IN UNSAFE TEMPERATURE OR PRESSURE BUILD-UP WHICH CAN RESULT IN PRODUCT FAILURE, SERIOUS INJURY OR DEATH AND/OR SEVERE PROPERTY DAMAGE AND VOID THE PRODUCT WARRANTY.**

**WARNING** **Chlorine Aggressive Water:** The water quality can significantly influence the life of this Product. You should test for corrosive elements, acidity, total solids and other relevant contaminants, including chlorine and treat your water appropriately to insure satisfactory performance and prevent premature failure.

**DANGER** **EXPLOSION HAZARD.** The pressure of the heat transfer medium must be limited to a maximum of 30 psig by an approved safety or relief valve on your boiler. The water heater pressure must be limited to 150 psig maximum by the installation of a temperature and pressure relief valve (included). The relief tube must be plumbed to a suitable drain per code. No reducing coupling or other restriction may be placed in this line.

**CAUTION** The heat transfer medium must be water or other nontoxic fluid having a toxicity rating or class of 1, as listed in Clinical Toxicology of Commercial Products, 5th edition. The pressure of the heat transfer medium must be limited to 30 PSIG by an approved safety or relief valve.

**WARNING** Do not expose Product to freezing temperatures or temperatures in excess of the maximum rated operating temperature.

**WARNING** This product can expose you to chemicals including lead, which is known to the State of California to cause cancer and birth defects or other reproductive harm. For more information go to [www.P65Warnings.ca.gov](http://www.P65Warnings.ca.gov).

**⚠ DANGER SCALDING HAZARD.** If the water temperature is over 120°F, household members can suffer serious or fatal scalding and painful and permanent injury.

- The Consumer Products Safety Commission recommends an initial setting of 120°F, but advised that a slower response time of infants, aged, disabled and other persons increases the scalding hazard and may require lower settings.
- Always check the water temperature before use, including washing, bathing or showering.
- Temperature limiting valves are available from your plumbing supplier. A check valve must be installed in the boiler return line to prevent gravity flow through the heat exchanger. This can cause overheating and result in serious or fatal scalding.

**⚠ DANGER SCALDING HAZARD.** If the thermostat is not working properly or if this product is not installed in accordance with the manual, water temperature can reach excessive levels that may cause serious or fatal scalding. After installation and any servicing of the unit, verify that the thermostat is working and firmly inserted in the thermostat well by following the thermostat testing instructions in the manual.

**⚠ WARNING** Failure to use the correct replacement parts may make your product unsafe.

**⚠ WARNING** In limited circumstances, space heating can be lost in the home with unit utilizing priority mode. Any demand for space heating is postponed until the water heater has reached its set temperature. This delay in supplying the space heating zones is usually not noticed by the inhabitants of the living spaces. However, in the event of certain malfunctions such as circulator or thermostat failure, space heating could be delayed indefinitely. If undetected and uncorrected, freezing damage to piping could result.

**⚠ CAUTION** If a steel hydropneumatic tank is in place, replace it with a properly sized diaphragm expansion tank. Otherwise, significant heat transfer problems can occur by causing air to be trapped in the heat exchanger. If the boiler system has a diaphragm expansion tank and the boiler temperatures are being changed, resize the expansion tank.

**⚠ WARNING** If installing on city water supply, a properly sized thermal expansion tank is required with the water heater and should be installed as set forth in the product installation manual. Contact your water supplier or local plumbing inspector for additional information.

**⚠ DANGER** Prevent pressure build-up in any existing internal tankless coil. Do not plug incoming or outgoing tapings in the internal tankless coil plate. Leave the coil in the boiler and leave system connections open to prevent pressure build-up.

**⚠ DANGER** **Electrocution hazard.** The water heater must be electrically grounded in accordance with local codes or, in the absence of local codes, with the National Electrical Code, ANSI/NFPA 70. Electrical supply must come from the boiler side of boiler's emergency shut-off switch in order to prevent unsafe boiler operation.

**⚠ DANGER** If not installed by the boiler manufacturer, install a low water cut-off or pressure reducing valve on your boiler so that leaking will not result in a dry boiler which if the boiler continues to fire, will cause an explosion hazard.

**⚠ DANGER** This unit must be installed as a separate heating zone. Do not connect this unit to an existing heating zone or feed boiler water directly through the coil as dangerous over-heating will result.

**⚠ CAUTION** Do not drain this appliance before shutting off the supply valve and opening the relief valve or another downstream fixture, as it will damage this unit. A vacuum breaker should be installed to avoid damaging the liner. Damage to the unit and leakage can occur if a vacuum breaker is not installed.

**⚠ CAUTION** As in all plumbing products and water storage vessels, bacteria can grow in this Product, especially during times of non-use. Consult your local plumbing professional regarding any steps you may wish to take to safely disinfect your home's plumbing system.

**⚠ WARNING** **USE GLYCOL ONLY WITH DOUBLE-WALLED HEAT EXCHANGER MODELS.** Glycol is a poisonous substance. To avoid seepage or leakage of glycol to surfaces where humans or animals can ingest it, use glycol only in double-walled units, so that any leaks will most likely be released to the atmosphere. However, a leak to a surface area may still occur, so any use of glycol must be monitored closely and humans and animals should be protected from contact with the unit.

**⚠ WARNING** Do not connect the water heater domestic supply with baseboard or other space heating units or elements. Any contaminants in the baseboard units will contaminate the potable water in the water heater and also adversely affect its performance.

**⚠ CAUTION** Do not drill, puncture or otherwise penetrate the steel outer tank shell. Do not screw pipe hangers or other hardware into the exterior of the tank.

**PLEASE READ THE FOLLOWING INSTRUCTIONS CAREFULLY**  
**IMPORTANT GENERAL SAFETY INFORMATION -**  
**ADDITIONAL SPECIFIC SAFETY ALERTS APPEAR IN THE FOLLOWING INSTRUCTIONS.**

**Pre-Installation**

- THIS PRODUCT MUST BE INSTALLED AND MAINTAINED BY A LICENSED PROFESSIONAL PLUMBER, ELECTRICIAN, AS APPLICABLE. IN ADDITION TO THE INSTRUCTIONS IN THIS MANUAL, FOLLOW ALL APPLICABLE LOCAL AND STATE CODES INCLUDING MA CMR 248 OR IN THE ABSENCE OF SUCH CODES, THE CURRENT EDITIONS OF THE NATIONAL PLUMBING CODE AND THE NATIONAL ELECTRIC CODE.
- DRIP PAN AND DRAIN: This appliance should not be installed in an area where leakage of the tank or connections can result in damage to the area adjacent to the appliance or to lower floors of the structure. When such locations cannot be avoided, a suitable drain pan, adequately drained and kept clear, must be installed under the appliance.
- CAUTION: Determine whether your water is corrosive or acidic, and that there are no suspended solids, toxic or other substances or abnormally high chlorine levels in the water that could damage or affect the water heater or the rest of your plumbing system.
- Wiring Options. Select either a Non-Priority or Priority System: Two options are available when wiring the controls of the water heater in the space heating system (boiler and distribution elements).
  1. **Non-Priority System** - The controls of the water heater must be wired as a separate heating zone with a standard zone valve or a separate circulator dedicated to the water heater "zone".  
**NOTICE:** In this non-priority option, the water heater will be supplied just as another zone. This means that if all space heating zones call for hot boiler water at the same time, the water heater may not be supplied with enough hot boiler water to "recover" adequately. The delivery of domestic hot water will be diminished. In many, but not all cases, this is not a problem because the routine oversizing of boiler output is adequate for both loads.
  2. **Priority System** - Under this wiring option the water heater will be supplied before space heating.



**WARNING** In limited circumstances, space heating can be lost in the home in this priority mode. Any demand for space heating is postponed until the water heater has reached its set temperature. This delay in supplying the space heating zones is usually not noticed by the inhabitants of the living spaces. However, in the event of certain malfunctions such as circulator or thermostat failure, space heating could be delayed indefinitely. If undetected and uncorrected, freezing damage to piping could result.

• **Select Circulator versus Zone Valve**

The flow of hot boiler water to the water heater can be controlled with either a motorized zone valve or a circulator.

1. **Separate circulator.** The recommended way to provide adequate flow through the water heater heat exchanger is to use a separate dedicated circulator. This option may be used even though the heating system utilizes zone valves.
  2. **Zone valve.** If a zone valve is to be used, a flow rate of 3 to 5 gpm with all zones in use is required. A full-port zone valve should be used.
- All installations require a low-water cut-off or automatic fill valve on your boiler system to reduce the risk of boiler water loss.
  - Steam boiler installations require a low-water cut-off which is also required by most codes.
  - Installation of a vacuum breaker is required to prevent damage to the water heater when drained. There must be no valves installed between the vacuum breaker and water heater.

**Required Components**

MODEL	CIRCULATOR	ZONE VALVE*	SHUTOFF VALVE	VACUUM BREAKER	RELIEF VALVE	THERMAL EXPANSION TANK	DRAIN
CH SERIES	4 GPM @ 6 FT	3/4" Full Port or 1" STD	4	1	Included	41 Gal. Models: 2 Gal. 80 Gal. Models: 4.4 Gal.	Included

\*IF CIRCULATOR IS NOT USED.

ALL INSTALLATIONS REQUIRE AN ADEQUATE AMOUNT OF TEFLON® SEALING TAPE OR PIPE DOPE FOR THREADED JOINTS.

**Heat Exchanger Pressure Drop**

Use this chart to select the proper circulator for your BOILERMATE®.

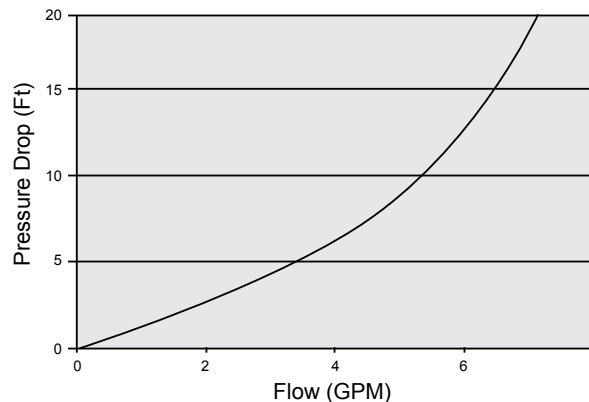

# Installation - Domestic Water Piping

1. Connect the cold water supply to the connection labeled COLD WATER.
2. Connect the HOT WATER piping to the domestic hot water system.
3. When all domestic water piping is complete, open the cold water supply and allow some water to enter the tank. Look and listen for signs of leaks and repair as necessary before continuing.
4. Install the temperature & pressure relief valve and plumb a blow down tube to within 6" above a floor drain or as directed by plumbing code.

Clearance From Combustible Surfaces			
LEFT SIDE.....	1"	REAR.....	1"
RIGHT SIDE.....	1"	FLOOR.....	0"
TOP.....	9"	FRONT.....	1"

Clearance for Servicing	
LEFT.....	12"
RIGHT.....	12"
FRONT.....	30"
HEAD ROOM.....	36"
REAR.....	1"

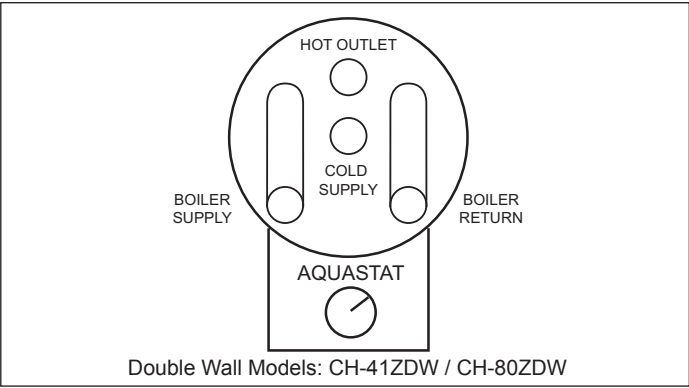
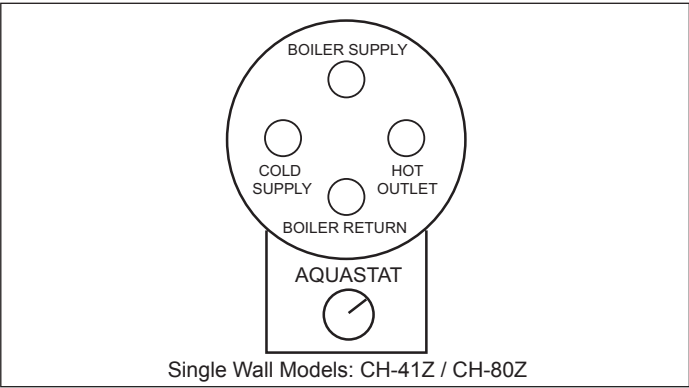

## CH Models

### PIPING USING DEDICATED CIRCULATOR PUMP (RECOMMENDED)

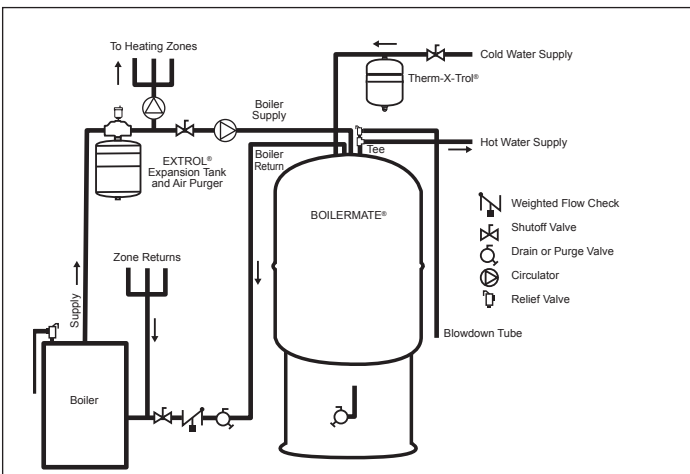

### PIPING USING ZONE VALVE WITH EXISTING HEATING SYSTEM CIRCULATOR

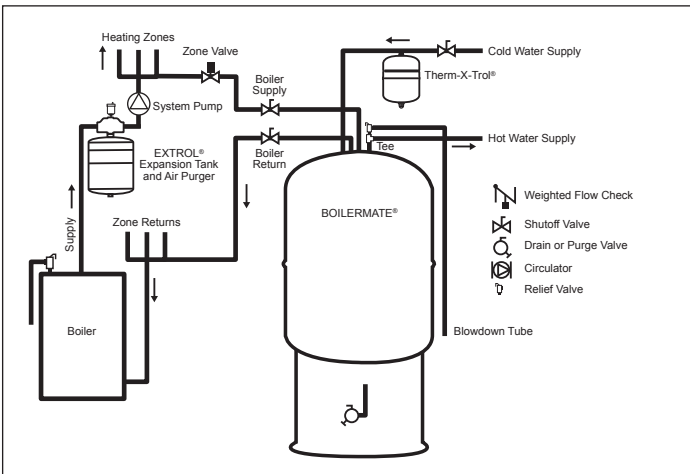

## Installation - Boiler Piping

1. Plumb the circulator or zone valve on the BOILER SUPPLY line.
2. Pipe the BOILER RETURN connection to the boiler return line.

**CAUTION** Be sure the return line is NOT plumbed to the suction side of any heating circulators. This may require moving the heating circulator off the boiler tapping on packaged boilers. Failure to do so will result in overheating and tank damage when the heating system is in operation.

3. Install a weighted flow check on the boiler return line. This is not necessary on systems utilizing a zone valve to control the water heater temperature.

4. After completing the boiler piping, slowly open the boiler fill valve and pressurize the water heater loop. Check for leaks and repair as necessary. Proceed to the appropriate wiring section in this manual.

**DANGER** EXPLOSION HAZARD. Do not install to a high pressure steam boiler (greater than 15 psig).

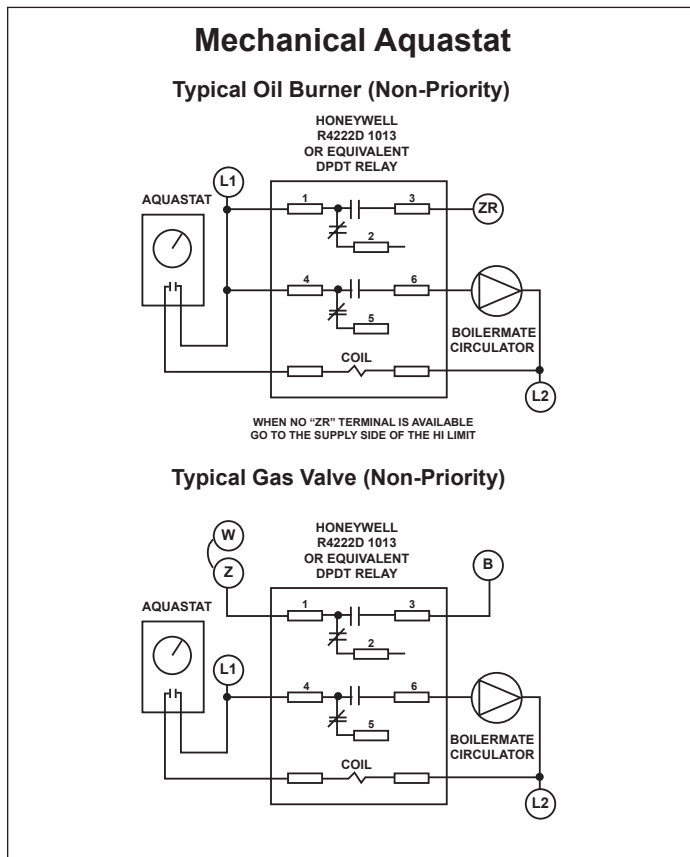

Note: if your application is not shown, contact AMTROL Technical Support at 401.535.1216.

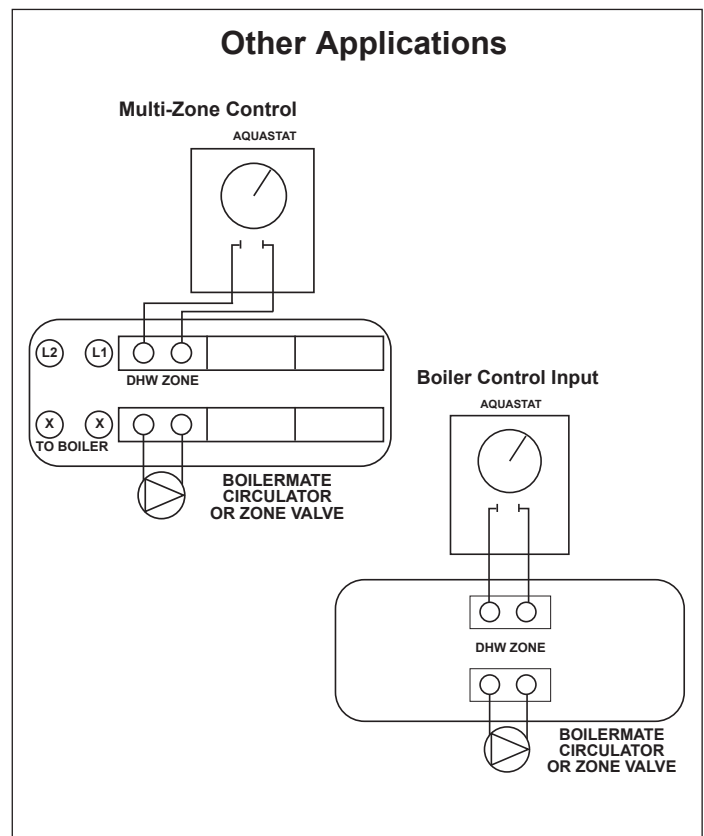
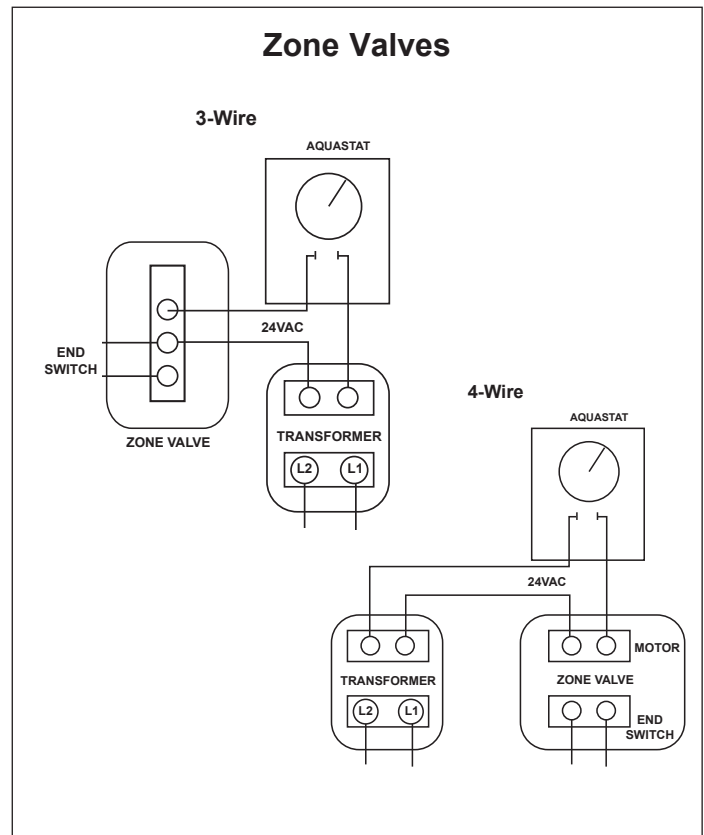

# Installation and Retrofit - Digital Control Wiring

1. Ensure the control installation is within the following application and operating parameters:

- Ambient temperature from 38° to 125°F.
- Relative humidity ranging from 20% to 90% (non-condensing).
- Boiler load rating up to 15A resistive, 1/4hp inductive @ 120VAC.
- Circulator load rating up to 15A, 1/4hp inductive @ 120VAC.
- Space heating load rating up to 8A @ 120VAC.

**NOTE:** Line-voltage and safety-circuit wiring that is external to the water heater jacket when all panels are in place, and which is part of the appliance, shall be protected by metal conduit, metal-clad cable or raceways. Thermoelectric wiring shall be exempt from this provision.

**NOTE:** Strain relief shall be provided for all conductors leaving an enclosure. For low-voltage wiring, strain relief at the point of exit from an enclosure is not necessary if, by wire location or support, protection is provided against accidental strain.

## Oil Burner Controls

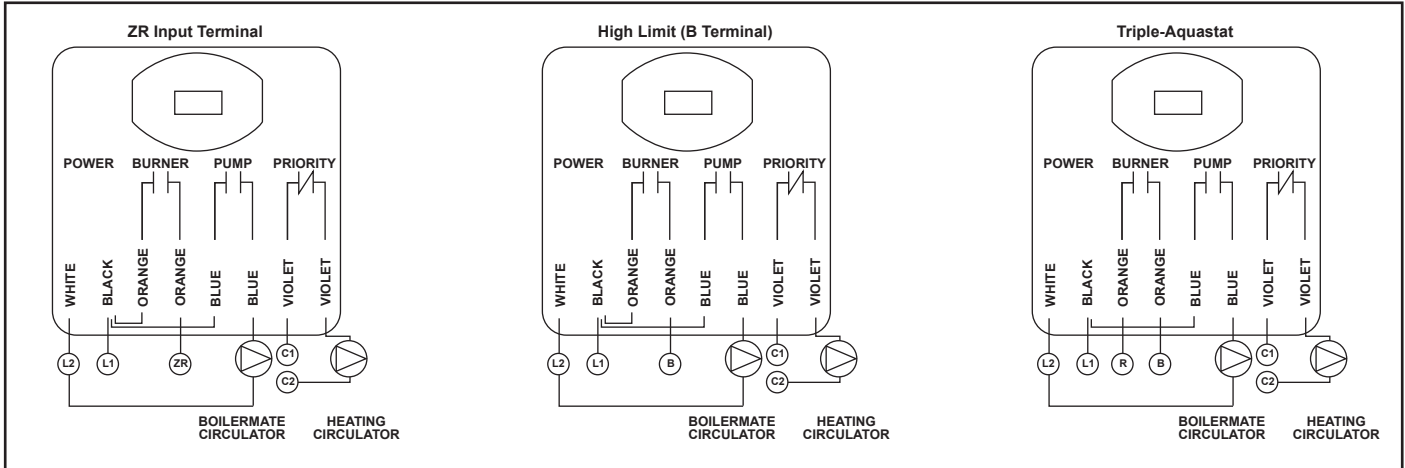

## Gas Valve Controls

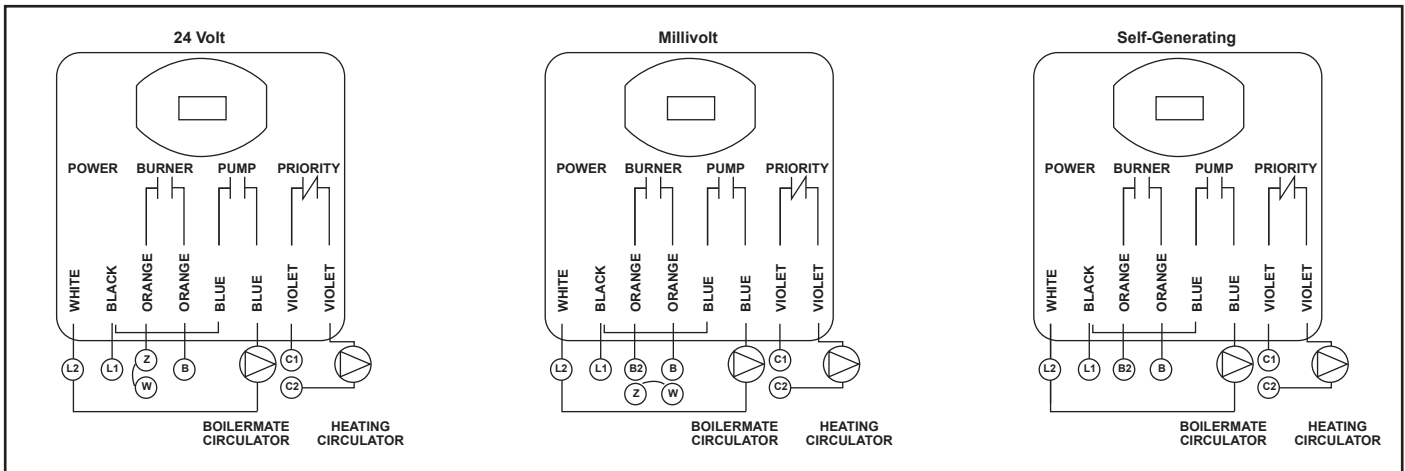

## Other Applications

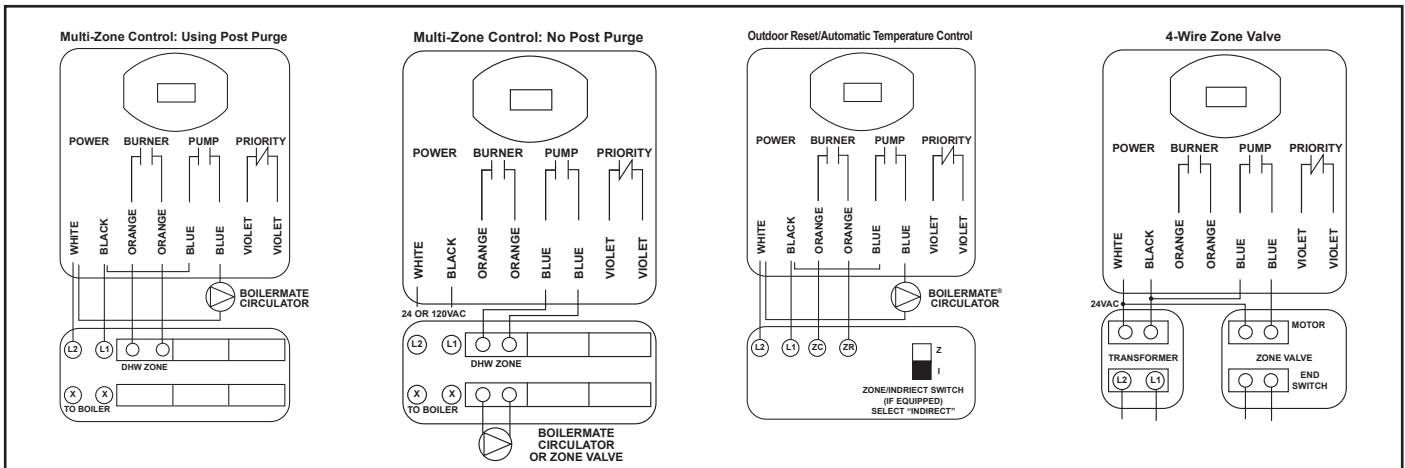

Note: if your application is not shown, contact AMTROL Technical Support at 401.535.1216.

## Installation - Digital Control Set-Up



After wiring per the appropriate diagram in this manual, insert the white temperature sensor (thermistor) plug into the receptacle at the base of the digital control. Zone valves can be slow actuating. Therefore, the zone valve sensor contains a built-in temperature offset to account for the time it takes the zone valve to fully close. This results in potable water temperature that is representative of the digital control temperature set point. This is why it is important to install the correct sensor into the digital control. See Page 3 for information regarding the selection of a circulator or zone valve.

**WARNING** Temperature settings above 120° F can create a scald hazard.

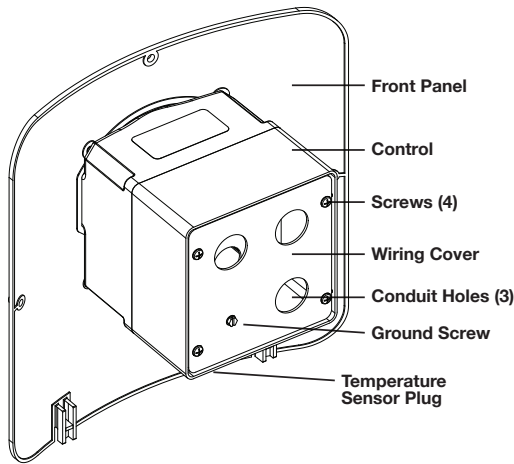

**Settings** To adjust, press and hold the **SET** button until the Temperature setting appears. Cycle through settings by depressing the **SET** button and using the **▼** and **▲** buttons to change the settings.

Setting	Code	Description	Range
Temperature	EP	Domestic hot water setpoint. Default is 120°F	90-150
Differential	dIF	Domestic hot water temperature drop before call for heat. Default is 10°F.	5,10
Post-Purge	PQS	Early boiler shutoff prior to hot water setpoint. Circulator runs until setpoint. Default is 0°F.	0,4,8* *Available only when Differential setting is 10.
Priority	Pr1	Temporarily cancels space heat to maximize available energy for hot water. Default is 'n'.	y/n
Capacity	CRP	Water heater capacity; select appropriate size for proper operation. Default is 41 Gallons.	26,41,60,80,120
BTU Transfer	btu	Real-time BTU transfer estimate in 1000 BTU/Hr increments. Diagnostic readout only.	0-199MBH/Hr

**Diagnostic Error Codes** Codes clear automatically when corrected or can be reset by interrupting power to the control for 5 seconds. To silence an alarm, depress the **▼** on the keypad.

Error	Code	Description	Potential Causes
Temp Sensor	Er1	Temperature sensor (thermistor) fault.	Sensor unplugged Sensor damaged
Overheating	HI Er2	Domestic hot water temperature has exceeded maximum setpoint.	Error in boiler plumbing Zone valve stuck open Leak in sensor well
Slow Heating	Er3	Unit has taken over 60 minutes to reach hot water setpoint or cannot reach setpoint.	Faulty equipment Fouled heat exchanger No fuel

**Operating Indicators** Water sensor temperature may be shown for 30 seconds by pressing the **▲** button.

Indicator	Code	Description
Startup Test	888	Displayed briefly during initial powerup to test LED display segments.
Idle	120	Static numeric [setpoint] readout (factory default shown) indicates domestic hot water setpoint.
Heating	On 120	Alternating On and [Setpoint] is displayed during a heating cycle while the circulator pump contacts are closed.

## Start-Up Procedure

**1. Purge Heat Exchanger:** The heat exchanger should be free of large air pockets to allow the circulator to operate properly. Using the diagram below as a guide, isolate the boiler return line and flush the loop until large air pockets are purged. After this, the air elimination equipment will collect smaller air bubbles.

### Purging Heat Exchanger (CH Series Shown)

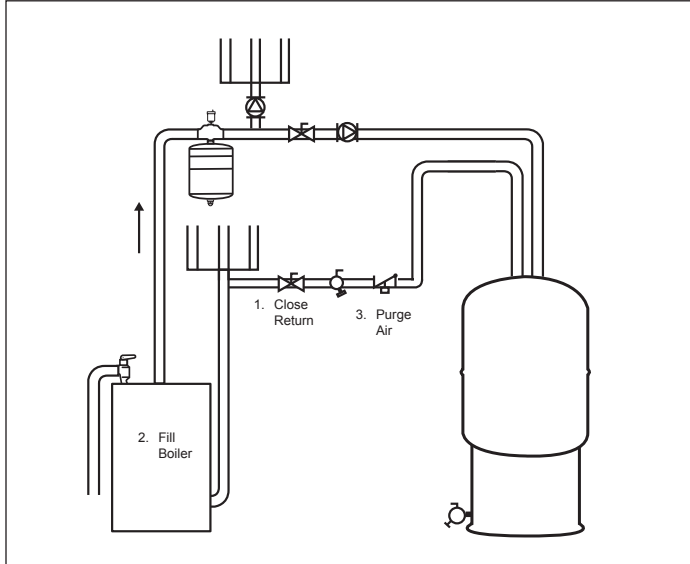

- 2. Fill Tank:** Open the hot water fixture furthest from the heater. Open the cold water supply and allow the water to run until air stops emerging. Air pockets may appear at any hot water fixture. This is considered normal and will clear as hot water is used.
- 3. Start Heater:** Turn power on to the unit. Digital Control models come pre-set to 120°F for safety. Mechanical controls should have the knob rotated to the 120°F mark. The circulator or zone valve should operate and the boiler should start.
- 4. Check Operation:** The water heater will begin to heat. Depending upon the size of the water heater, output of the boiler and the space heating load, the unit should typically reach set temperature within 15 to 60 minutes. If heating does not occur, consult the troubleshooting section in this manual. **Note:** Large heaters coupled with small boilers may exceed this time period upon initial startup.
- 5. Set Temperature:** The control should be set to the minimum temperature consistent with the user's needs. This maximizes efficiency and reduces scald potential.

## MAINTENANCE

The water heater and system should be periodically checked by a licensed professional at least annually and more often as system ages.

## WARRANTY

CH Models: Six (6) year limited warranty on heat exchanger and tank assembly only. Visit [www.amtrol.com](http://www.amtrol.com) for complete warranty details.

## Troubleshooting

PROBLEM	POSSIBLE CAUSES	SOLUTION
No hot water	<ol style="list-style-type: none"> <li>1. No power to unit</li> <li>2. Circulator air-bound</li> <li>3. Faulty circulator or zone valve</li> <li>4. Faulty control</li> <li>5. Boiler inoperable</li> </ol>	<ol style="list-style-type: none"> <li>1. Check circuit breaker, boiler emergency switch and boiler reset switch.</li> <li>2. Purge air. Ensure circulator is on Boiler Supply. Check air vents.</li> <li>3. Check circulator and zone valve. Repair or replace if necessary.</li> <li>4. Check continuity. Switching circuits should close. If not, replace control.</li> <li>5. Check boiler system. Boiler must operate to generate hot water.</li> </ol>
Insufficient hot water	<ol style="list-style-type: none"> <li>1. Demand exceeds capacity</li> <li>2. Temperature too low</li> <li>3. Boiler lacks output for simultaneous heat &amp; hot water</li> <li>4. Fouled heat exchanger</li> <li>5. Insufficient heat exchanger flow</li> </ol>	<ol style="list-style-type: none"> <li>1. Check sizing based on household size and boiler output.</li> <li>2. Increase temperature setpoint.</li> <li>3. Set up for priority. If problem persists add storage or increase tank size.</li> <li>4. Check Boiler Supply/Boiler Return during cold startup. If difference is less than 20°F, clean heat exchanger as outlined below. Install water treatment equipment to prevent recurrence.</li> <li>5. Check for undersized or faulty circulator, stuck or undersized zone valve. Ensure all shutoff valves are open. Check for stuck flow check valve. Purge boiler loop to remove air.</li> </ol>
Water too hot	<ol style="list-style-type: none"> <li>1. Improper plumbing</li> <li>2. Temperature set too high</li> <li>3. Temperature sensor not fully inserted</li> <li>4. Stuck zone valve</li> <li>5. Flow check valve stuck open</li> </ol>	<ol style="list-style-type: none"> <li>1. If Boiler Return is plumbed to the suction-side of a heating circulator, overheating will occur when the home's heat is on. Fix plumbing.</li> <li>2. Reduce temperature setting.</li> <li>3. Re-insert temperature sensor.</li> <li>4. Repair or replace.</li> <li>5. Clean, repair or replace.</li> </ol>
Relief valve dripping or opening	<ol style="list-style-type: none"> <li>1. Thermal expansion tank undersized or missing</li> <li>2. Thermal expansion tank set improperly</li> <li>3. City pressure too high</li> <li>4. System over temperature</li> <li>5. Faulty relief valve</li> </ol>	<ol style="list-style-type: none"> <li>1. Install the properly sized thermal expansion tank.</li> <li>2. Ensure precharge air pressure matches static water pressure.</li> <li>3. Install a Pressure Reducing Valve (PRV) if city pressure is over 80psi.</li> <li>4. Determine cause of over temperature condition and correct problem.</li> <li>5. Replace relief valve.</li> </ol>
Discolored water at faucet	<ol style="list-style-type: none"> <li>1. Poor water quality</li> <li>2. Sediment or suspended particles</li> </ol>	<ol style="list-style-type: none"> <li>1. Have water tested for contaminants.</li> <li>2. Install sediment filter, purge unit more often to avoid future problems.</li> </ol>
Boiler will not operate when calling for hot water	<ol style="list-style-type: none"> <li>1. Improper or loose wiring</li> <li>2. Boiler high limit has been reached</li> <li>3. Post Purge (POS) set too high</li> <li>4. Problem with boiler system</li> </ol>	<ol style="list-style-type: none"> <li>1. Check connections against wiring diagrams in this manual.</li> <li>2. Boiler will periodically cycle on and off during operation.</li> <li>3. Post Purge shuts the boiler off prior to reaching domestic setpoint. If set too high, the boiler may not have enough energy to raise the water temperature to setpoint. Reduce POS or set to 0 if the problem persists.</li> <li>4. Have boiler diagnosed for proper operation.</li> </ol>

## Replacement Parts

Description	ID	CH-41 Models	CH-80 Models
Heat Exchanger Replacement, Single Wall	1	393200	393169
Heat Exchanger Replacement, Double Wall		2800R001	2701R007
Cold Water Inlet Tube	2	393199	393168
Digital Control Kit (also for replacement of WH units)	3	396411	396411
T&P Safety Relief Valve	4	393107	393107
Mechanical Temperature Control	5	393232	393232
2 Covers (front and back) without Control	6	2703R013	2703R013
2 Covers (front and back) with Control		2703R042	2703R042



To obtain replacement parts, contact the installer or place of purchase.  
 Technical support is available by calling AMTROL at (401) 535-1216.







1400 Division Road, West Warwick, RI 02893 USA  
T: 800.426.8765 www.amtrol.com



© 2025 Worthington Enterprises  
One or more features of this product are covered by U.S. patents, visit [www.amtrol.com/patents](http://www.amtrol.com/patents) for more information.

Part #: 9040-586 (07/25)